

## TÜV RHEINLAND ENERGY GMBH



Report on the performance test of the 49iQ ambient air quality measuring system for Ozone manufactured by Thermo Fisher Scientific

TÜV Report 936/21242986/A  
Cologne, 2 October 2018

[www.umwelt-tuv.de](http://www.umwelt-tuv.de)



[tre-service@de.tuv.com](mailto:tre-service@de.tuv.com)

**TÜV Rheinland Energy GmbH and its Ambient Air Quality department in particular**  
is accredited for the following activities:

- Determination of emissions and ambient air quality affected by air pollutants and odorous substances,
- Inspection of correct installation, functionality and calibration of continuous emission monitoring systems including systems for data evaluation and remote monitoring of emissions,
- Measurements in combustion chambers;
- Performance testing of measuring systems for continuous monitoring of emissions and air quality as well as electronic data evaluation and remote monitoring systems for emissions
- Determination of the stack height and air quality forecasts for hazardous and odorous substances;
- Determination of emissions and ambient air quality affected by noise and vibration, determination of sound power levels and noise measurements at wind turbines;

**according to EN ISO/IEC 17025.**

The accreditation will expire on 10-12-2022 and covers the scope specified in the annex to certificate D-PL-11120-02-00.

Reproduction of extracts from this test report is subject to prior written consent.

**TÜV Rheinland Energy GmbH**  
**D - 51105 Köln, Am Grauen Stein,**  
**Tel: + 49 (0) 221 806-5200, fax: +49 (0) 221 806-1349**

**Blank page**



## **Report on the performance test of the 49iQ ambient air quality measuring system for Ozone manufactured by Thermo Fisher Scientific**

<b>AMS designation:</b>	49iQ
<b>Manufacturer:</b>	Thermo Fisher Scientific 27, Forge Parkway Franklin, MA 02038 USA
<b>Test period:</b>	April 2018 to October 2018
<b>Date of report:</b>	2 October 2018
<b>Report Number:</b>	936/21242986/A
<b>Editor:</b>	Dipl.-Ing. Martin Schneider Phone: +49 221 806-1614 <a href="mailto:martin.schneider@de.tuv.com">martin.schneider@de.tuv.com</a>
<b>Scope of the report:</b>	Report: 120 pages Manual 120 et. seq. Manual 276 pages Total 396 pages

**Blank page**

## Table of contents

1. SUMMARY AND CERTIFICATION PROPOSAL.....	12
1.1 Summary Overview .....	12
1.2 Certification proposal.....	13
1.3 Summary report on test results.....	14
2. TASK DEFINITION.....	20
2.1 Nature of the test.....	20
2.2 Objectives .....	20
3. DESCRIPTION OF THE AMS TESTED .....	21
3.1 Measuring principle .....	21
3.2 AMS scope and set-up .....	23
3.3 AMS adjustment .....	25
4. TEST PROGRAMME .....	26
4.1 General remarks.....	26
4.2 Laboratory test .....	27
4.3 Field test.....	27
5. REFERENCE MEASUREMENT METHOD .....	28
5.1 Method of measurement.....	28
6. TEST RESULTS IN ACCORDANCE WITH VDI 4202, PART 1 (2018).....	29
6.1 7.3 General requirements .....	29
6.1 7.3.1 Measured value display .....	29
6.1 7.3.2 Calibration inlet .....	30
6.1 7.3.3 Easy maintenance .....	31
6.1 7.3.4 Functional check.....	32
6.1 7.3.5 Set-up times and warm-up times.....	33

6.1	7.3.6 Instrument design .....	34
6.1	7.3.7 Unintended adjustment .....	35
6.1	7.3.8 Data output .....	36
6.1	7.3.9 Digital interface .....	37
6.1	Data transmission protocol .....	38
6.1	7.3.11 Measuring range .....	39
6.1	7.3.12 Negative output signals .....	40
6.1	7.3.13 Failure in the mains voltage .....	41
6.1	7.3.14 Operating states .....	42
6.1	7.3.15 Switch-over .....	43
6.1	7.3.16 Instrument software .....	44
6.1	7.4 Requirements on performance characteristics for laboratory testing .....	45
6.1	7.4.1 General requirements .....	45
6.1	7.4.2 Test requirements .....	46
6.1	7.4.3 Response time and memory effect .....	48
6.1	7.4.4 Short-term drift .....	49
6.1	7.4.5 Repeatability standard deviation .....	50
6.1	7.4.6 Linearity .....	51
6.1	7.4.7 Sensitivity coefficient to sample gas pressure .....	52
6.1	7.4.8 Sensitivity coefficient to sample gas temperature .....	53
6.1	7.4.9 Sensitivity coefficient to surrounding temperature .....	54
6.1	7.4.10 Sensitivity coefficient to electrical voltage .....	55
6.1	7.4.11 Cross sensitivity .....	56
6.1	7.4.12 Averaging effect .....	57
6.1	7.4.13 Difference between sample and calibration port .....	58
6.1	7.4.14 Converter efficiency .....	59

6.1	7.4.15 Residence time in the analyser .....	60
6.1	7.5 Requirements on performance characteristics for testing in the field.....	61
6.1	7.5.1 General requirements .....	61
6.1	7.5.2 Location for the field test .....	62
6.1	7.5.3 Test requirements .....	63
6.1	7.5.4 Long-term drift .....	64
6.1	7.5.5 Reproducibility standard deviation under field conditions .....	65
6.1	7.5.6 Inspection interval .....	66
6.1	7.5.7 Availability .....	67
6.1	7.5.8 Converter efficiency .....	68
6.1	7.6 Type approval and calculation of the measurement uncertainty .....	69
7.	TEST RESULTS IN ACCORDANCE WITH STANDARD EN 14625 (2012).....	70
7.1	8.4.3 Response time .....	70
7.1	8.4.4 Short-term drift .....	74
7.1	8.4.5 Repeatability standard deviation .....	78
7.1	8.4.6 Lack of fit of linearity of the calibration function .....	81
7.1	8.4.7 Sensitivity coefficient to sample gas pressure .....	86
8.4.8	Sensitivity coefficient to sample gas temperature .....	88
7.1	8.4.9 Sensitivity coefficient to surrounding temperature .....	90
7.1	8.4.10 Sensitivity coefficient to electrical voltage.....	93
7.1	8.4.11 Interferents.....	95
7.1	8.4.12 Averaging test.....	98
7.1	8.4.13 Difference sample/calibration port.....	101
7.1	8.4.14 Residence time in the analyser .....	103
7.1	8.5.4 Long-term drift .....	104
7.1	8.5.5 Reproducibility standard deviation or ozone under field conditions .....	107

7.1	8.5.6 Inspection interval .....	110
7.1	8.5.7 Period of availability of the analyser .....	111
7.1	8.6 Calculation of the total uncertainty according to EN 14625 (2012) .....	113
8.	RECOMMENDATIONS FOR USE IN PRACTICE .....	118
9.	BIBLIOGRAPHY .....	119
10.	APPENDICES .....	120



## List of tables

Table 1:	Measuring ranges tested .....	12
Table 2:	Technical data 49iQ (manufacturer specifications).....	25
Table 3:	Certification ranges VDI 4202-1 and EN 14625 .....	39
Table 4:	Response time of the 49iQ measuring system for ozone .....	72
Table 5:	Individual results of the response time for ozone .....	73
Table 6:	Results for the short-term drift.....	75
Table 7:	Individual results for the short-term drift 1 Test gas application:.....	76
Table 8:	Individual results for the short-term drift 2 Test gas application:.....	77
Table 9:	Repeatability standard deviation at zero and reference point.....	79
Table 10:	Individual test results obtained for the repeatability standard deviation .....	80
Table 11:	Deviation from the analytical function for ozone .....	83
Table 12:	Individual results of the lack-of-fit test.....	85
Table 13:	Sensitivity coefficient of sample gas pressure .....	87
Table 14:	Individual results of the sensitivity to changes in sample gas pressure.....	87
Table 15:	Sensitivity coefficient to sample gas temperature .....	89
Table 16:	Individual results for the determination of the sensitivity to sample gas temperature.....	89
Table 17:	Sensitivity coefficients to surrounding temperature.....	91
Table 18:	Individual test results for the sensitivity coefficient to ambient temperature .....	92
Table 19:	Sensitivity coefficient to electrical voltage.....	94
Table 20:	Individual results of the sensitivity coefficient to electrical voltage .....	94
Table 21:	Interferents in accordance with EN 14625 .....	96
Table 22:	Influence of the tested interferents ( $c_t = 120 \text{ nmol/mol}$ ) .....	96
Table 23:	Individual results for testing interferents .....	97
Table 24:	Results of the averaging test.....	99
Table 25:	Individual results of the averaging test.....	100
Table 26:	Results of determining the difference between sample/calibration inlet .....	101
Table 27:	Individual results for testing the difference between sample and calibration port .....	102
Table 28:	Results for the long-term drift at zero point.....	105
Table 29:	Results for the long-term drift at reference point.....	105
Table 30:	Individual results for differences .....	106
Table 31:	Determination of the reproducibility standard deviation on the basis of complete field test data.....	108
Table 32:	Availability of the 49iQ measuring system .....	112
Table 33:	Relevant performance characteristics and criteria according to EN 14625 ....	114
Table 34:	Expanded uncertainty from the results obtained in the laboratory tests for analyser 1 .....	116
Table 35:	Expanded uncertainty from the results obtained in the laboratory and field tests for analyser 1 .....	116
Table 36:	Expanded uncertainty from the results obtained in the laboratory tests for analyser 2 .....	117
Table 37:	Expanded uncertainty from the results obtained in the laboratory and field tests for analyser 2 .....	117

## List of figures

Figure 1:	View of the 49iQ measuring system.....	21
Figure 2:	Flow schematic.....	22
Figure 3:	Inside View of the Instrument- Top View.....	24
Figure 4:	Inside View of the Instrument – Side View.....	24
Figure 5:	Software version of the 49iQ instruments for testing.....	26
Figure 6:	Tested 49iQ instruments with measured value display.....	29
Figure 7:	Diagram illustrating the response time.....	71
Figure 8:	Analytical function obtained from the group averages for system 1.....	83
Figure 9:	Analytical function obtained from the group averages for system 2.....	84
Figure 10:	Test of the averaging effect ( $t_{O_3} = t_{zero} = 45$ s.).....	99
Figure 11:	Diagram illustrating the reproducibility standard deviation under field conditions .....	109
Figure 12:	Certificate of accreditation according to EN ISO/IEC 17025:2005.....	121

**Blank page**

## 1. Summary and certification proposal

### 1.1 Summary Overview

Thermo Fisher Scientific commissioned TÜV Rheinland Energy GmbH to carry out performance testing for the 49iQ measuring system for ozone. The test was performed in respect of the following standards and requirements:

- VDI Guideline 4202 part 1: Performance test, declaration of suitability, and certification of point-related measuring systems for gaseous air pollutants of April 2018
- EN 14625: Ambient air - Standard method for the measurement of the concentration of ozone by ultraviolet photometry (August 2012)

The 49iQ measuring system uses ultraviolet photometry to measure ozone. The measuring system thus corresponds to the EU reference method specified in EN 14625. The tests were performed in the laboratory and in a three-months field test in Cologne. The following measuring range was tested:

*Table 1: Measuring ranges tested*

Measured components:	measuring range in [ $\mu\text{g}/\text{m}^3$ ] <sup>1</sup>	Measuring range in [ppb] or [nmol/mol]
Ozone	0–500	0–250

<sup>1</sup> The specifications refer to 20 °C and 101.3 kPa

The minimum requirements were satisfied during the performance test.

TÜV Rheinland Energy GmbH therefore recommend the instrument's approval as a performance-tested measuring system for continuous monitoring of air quality affected by ozone.

## 1.2 Certification proposal

Based on the positive results obtained, the following recommendation on the announcement of the AMS as a certified system is put forward:

**AMS designation:**

49iQ for Ozone

**Manufacturer:**

Thermo Fisher Scientific, Franklin, USA

**Field of application:**

For the continuous measurement of ozone concentrations from stationary sources in ambient air

**Measuring ranges during performance testing:**

Component	Certification range	Unit
Ozone	0–500	µg/m <sup>3</sup>

**Software version:**

Version: 1.5.1.32120

**Restrictions**

None

**Note:**

This report on the performance test is available online at [www.gal1.de](http://www.gal1.de).

**Test Report:**

TÜV Rheinland Energy GmbH, Cologne

Report No.: 936/21242986/A dated 2 October 2018

### 1.3 Summary report on test results

Performance criterion	Requirement	Test result	Satisfied	Page
<b>7 Performance criteria</b>				
<b>7.3 General requirements</b>				
7.3.1 Measured value display	The measuring system shall have an operative measured value display as part of the instrument.	The measuring system has an operative measured value display at the instrument front.	yes	29
7.3.2 Calibration inlet	The measuring system may have a test gas inlet separate from the sample gas inlet.	The measuring system has a test gas inlet separate from the sample gas inlet at the instrument back.	yes	30
7.3.3 Easy maintenance	Maintenance should be possible without larger effort, if possible from outside.	Maintenance takes reasonable effort and is possible with standard tools from the outside.	yes	31
7.3.4 Functional check	Particular instruments required to this effect shall be considered as part of the measuring system and be applied in the corresponding sub-tests and included in the assessment.	The tested measuring system does not have internal devices for operating the functional check.	not applicable	32
7.3.5 Set-up times and warm-up times	The instruction manual shall include specifications in this regard.	Set-up times and warm-up times have been determined.	yes	33
7.3.6 Instrument design	The instruction manual shall include specifications in this regard.	Specifications made in the instruction manual concerning instrument design are complete and correct.	yes	34
7.3.7 Unintended adjustment	Shall secure measuring system against that.	The measuring system is secured against unintended and unauthorised adjustment of instrument parameters by way of a password.	yes	35
7.3.8 Data output	The output signals shall be provided digitally and/or as analogue signals.	Measured signals are provided as analogue (0–20 mA, 4–20 mA or 0–1 V, 0–10 V) and digital signals (via TCP/IP, RS 232, USB).	yes	36
7.3.9 Digital interface	The digital interface shall allow the transmission of output signals, status signals, and others.  Access to the measuring system shall be secured against unauthorised access.	Digital transmission of measured values operates correctly.	yes	37

Performance criterion	Requirement	Test result	Satisfied	Page
Data transmission protocol	Shall meet the requirements stipulated in Table 1 of VDI Guideline 4202 part 1.	By default, the measuring system comes with an installed Modbus protocol. Measured and status signals are transmitted correctly. Customers of Thermo Fisher Scientific can look up commands on the internet.	yes	38
7.3.11 Measuring range	The upper limit of measurement shall be greater or equal to the upper limit of the certification range.	The default measuring range is set to 0–250 ppb (500 µg/m <sup>3</sup> ) for ozone. Supplementary measuring ranges up to 0–200 ppm are possible. The measuring system's upper limit of measurement exceeds the upper limit of the certification range in each case.	yes	39
7.3.12 Negative output signals	May not be suppressed (life zero).	The measuring system also provides negative output signals.	yes	40
7.3.13 Failure in the mains voltage	Uncontrolled emission of operation and calibration gas shall be avoided; instrument parameters shall be secured by buffering against loss; when mains voltage returns, the instrument shall automatically reach the operation mode and start the measurement.	On return of mains voltage, the instrument returns to normal operating mode and automatically resumes measuring.	yes	41
7.3.14 Operating states	The measuring system shall allow their control by telemetrically transmitted status signals.	The measuring system provides various ports to ensure comprehensive monitoring and control via an external computer.	yes	42
7.3.15 Switch-over	Switch-over between measurement and functional check and/or calibration shall be possible telemetrically.	In principle, it is possible to monitor all tasks necessary for a functional check on the instrument itself or telemetrically.	yes	43
7.3.16 Instrument software	Shall be displayed when switched on. Changes affecting instrument functions shall be communicated to the test laboratory.	The instrument's software version is displayed. Software changes are communicated to the test laboratory.	yes	44

Performance criterion	Requirement	Test result	Satisfied	Page
<b>7.4 Requirements on performance characteristics for testing in the laboratory</b>				
7.4.1 General requirements	The manufacturer's specifications in the instruction manual shall not contradict the results of the performance test.	Tests were performed using the performance characteristics specified in VDI standard 4202, part 1 (2018) and standard EN 14625 (2012)	yes	45
7.4.2 Test requirements	Has to comply with the requirements set out in VDI standard 4202-1:2018.	Tests were performed using the performance characteristics specified in VDI standard 4202, part 1 (2018) and standard EN 14625 (2012)	yes	46
Section 8.4 provides a summary of the evaluation of performance characteristics determined in the laboratory.				
<b>7.5 Requirements on performance characteristics for testing in the field</b>				
7.5.1 General requirements	Has to comply with the requirements set out in VDI standard 4202-1:2018.	Tests were performed using the performance characteristics specified in VDI standard 4202, part 1 (2018) and standard EN 14625 (2012)	yes	61
7.5.2 Location for the field test	The monitoring station for the field test is to be chosen according to the requirements of 39. BImSchV such that the expected concentrations of the measured components to be measured correspond to the designated task. The equipment of the monitoring station shall allow the implementation of the field test and shall fulfil all requirements considered to be necessary during measurement planning.	The field test location was selected in compliance with the 39 <sup>th</sup> BImSchV.	yes	62
7.5.3 Test requirements	The measuring systems shall be installed in the monitoring station and, after connecting to the existing or separate sampling system, activated properly.  The adjustments of the measuring system shall meet the specifications of the manufacturer. All adjustments are to be documented in the test report.	During the field test, the measuring system was operated and serviced according to the manufacturer's instructions.	yes	63
Section 8.5 provides a summary of the evaluation of performance characteristics determined in the laboratory.				



Performance criterion	Requirement	Test result	Satisfied	Page
<b>8.4 Procedures for determination of the performance characteristics during the laboratory test</b>				
8.4.3 Response time	Rise and fall response time $\leq$ 180 s each. Difference between rise and fall response time $\leq$ 10 s.	The values determined remained considerably below the maximum permissible response time of 180 s at all times. The maximum response time determined for system 1 was 60.75 s, for system 2, it was 61.5 s.	yes	70
8.4.4 Short-term drift	The short-term drift at zero must be $\leq$ 2.0 nmol/mol/12 h. The short-term drift at span level must be $\leq$ 6.0 nmol/mol/12 h.	For instrument 1 the value for the short-term drift at zero point was -0.11 nmol/mol/12 h, for instrument 2 it was -0.30 nmol/mol/12 h. Short-term drift at reference point was -0.62 nmol/mol/12 h for instrument 1 and -0.25 nmol/mol/12 h for instrument 2.	yes	74
8.4.5 Repeatability standard deviation	The performance criteria are as follows: Repeatability standard deviation at zero shall not exceed 1.0 nmol/mol. At a sample gas concentration at the reference point it shall not exceed 3.0 nmol/mol.	For instrument 1 the value for the repeatability standard deviation at zero point was 0.19 nmol/mol, for instrument 2 it was 0.20 nmol/mol. Repeatability standard deviation at reference point was 0.34 nmol/mol for instrument 1 and 0.39 nmol/mol for instrument 2.	yes	78
8.4.6 Lack of fit of linearity of the calibration function	The deviation from the linearity of the calibration function at zero shall not exceed 5.0 nmol/mol. At concentrations above zero, it shall not exceed 4% of the measured value.	The deviation from the linear regression line for instrument 1 is 1.88 nmol/mol at zero point and no more than 1.28% of the target value for concentrations above zero. The deviation from the linear regression line for instrument 2 is 1.48 nmol/mol at zero point and no more than 0.47% of the target value for concentrations above zero.	yes	81
8.4.7 Sensitivity coefficient to sample gas pressure	The sensitivity coefficient to sample gas pressure shall be $\leq$ 2.0 nmol/mol/kPa.	For instrument 1, the sensitivity coefficient to sample gas pressure is 0.20 nmol/mol/kPa. For instrument 2, the sensitivity coefficient to sample gas pressure is 0.14 nmol/mol/kPa.	yes	86

Performance criterion	Requirement	Test result	Satis- fied	Page
8.4.8 Sensitivity coefficient to sample gas temperature	The sensitivity coefficient to sample gas temperature shall be $\leq 1.0 \mu\text{mol/mol/K}$ .	For instrument 1, the sensitivity coefficient to sample gas temperature is $0.09 \text{ nmol/mol/K}$ . For instrument 2, the sensitivity coefficient to sample gas temperature is $0.05 \text{ nmol/mol/K}$ .	yes	88
8.4.9 Sensitivity coefficient to surrounding temperature	The sensitivity coefficient to surrounding temperature shall be $\leq 1.0 \mu\text{mol/mol/K}$ .	The sensitivity coefficient to the surrounding temperature did not exceed the performance criterion specified at $1.0 \text{ nmol/mol/K}$ . For the purpose of uncertainty calculation, the largest value is used for both instruments. For instrument 1, this is $0.115 \text{ nmol/mol/K}$ and for instrument 2 it is $0.091 \text{ nmol/mol/K}$ .	yes	90
8.4.10 Sensitivity coefficient to electrical voltage	The sensitivity coefficient to electrical voltage shall not exceed $0.30 \text{ nmol/mol/V}$ .	At no test item did the sensitivity coefficient to electrical voltage exceed the value of $0.3 \text{ nmol/mol/V}$ specified in standard EN 14625. For the purpose of uncertainty calculation, the largest value is used for both instruments. For instrument 1, this is $0.02 \text{ nmol/mol/V}$ and for instrument 2 it is $0.01 \text{ nmol/mol/V}$ .	yes	93
8.4.11 Interferents	Interferents at zero and at concentration $c_i$ . The deviation caused by the interferent $\text{H}_2\text{O}$ shall not exceed $10.0 \text{ nmol/mol}$ ; for toluene, and m-xylenes, it shall not exceed $5.0 \text{ nmol/mol}$ .	At zero point the result for the interference were $-2.03 \text{ nmol/mol}$ (AMS 1) and $-0.89 \text{ nmol/mol}$ (AMS 2) for $\text{H}_2\text{O}$ , $1.46 \text{ nmol/mol}$ (AMS 1) and $2.24 \text{ nmol/mol}$ (AMS 2) for toluene and finally $2.30 \text{ nmol/mol}$ (AMS 1) and $2.45 \text{ nmol/mol}$ (AMS 2) for m-xylene. At the limit value, the result for the interference were $-1.67 \text{ nmol/mol}$ (AMS 1) and $-0.47 \text{ nmol/mol}$ (AMS 2) for $\text{H}_2\text{O}$ , $4.27 \text{ nmol/mol}$ (AMS 1) and $4.05 \text{ nmol/mol}$ (AMS 2) for toluene and finally $4.75 \text{ nmol/mol}$ (AMS 1) and $4.63 \text{ nmol/mol}$ (AMS 2) for m-xylene.	yes	95
8.4.12 Averaging test	The averaging effect shall not exceed 7% of the measured value.	The performance criterion specified by standard EN 14625 is fully satisfied.	yes	98

Performance criterion	Requirement	Test result	Satisfied	Page
8.4.13 Difference sample/calibration port	The difference between the sample and calibration ports shall not exceed 1%.	The performance criterion specified by standard EN 14625 is fully satisfied.	yes	101
8.4.14 Residence time in the analyser	The residence time in the analyser shall not exceed 3.0 s.	Residence time in the analyser was 1.0 s.	yes	103
<b>8.5 Determination of the performance characteristics during the field test according to EN 14625</b>				
8.5.4 Long-term drift	The long-term drift at zero point shall not exceed $\leq 5.0$ nmol/mol. Long-term drift at span level shall not exceed 5% of the certification range.	Maximum long-term drift at zero point $DI_z$ was at 1.89 nmol/mol for instrument 1 and 1.65 nmol/mol for instrument 2. Maximum long-term drift at reference point $DI_s$ was at -2.70% for instrument 1 and 1.81% for instrument 2.	yes	104
8.5.6 Inspection interval	The period of unattended operation of the AMS shall be at least 2 weeks.	The necessary maintenance tasks determine the period of unattended operation. In essence, these include contamination checks, plausibility checks and checks of potential status/error warnings. The external particle filter needs replacing at the measurement site after having been subjected to dust loading. EN 14625 requires checking of zero and span points at least once every two weeks.	yes	110
8.5.5 Reproducibility standard deviation or ozone under field conditions	Reproducibility standard deviation under field conditions shall not exceed 5% of the mean value over a period of three months.	The reproducibility standard deviation for ozone under field conditions was 2.42% as a percentage of the mean value over the three-months field test period. Thus, the requirements of EN 14625 are satisfied.	yes	107
8.5.7 Period of availability of the analyser	Availability of the analyser shall be at least 90%.	The availability is 100%. Thus, the requirement of EN 14625 is satisfied.	yes	111

## 2. Task Definition

### 2.1 Nature of the test

Thermo Fisher Scientific commissioned TÜV Rheinland Energy GmbH to submit the 49iQ air quality monitor to performance testing. The test was carried out as a complete performance test.

### 2.2 Objectives

The AMS is designed to determine ozone concentrations in ambient air in the following concentration ranges:

Component	Certification range	Unit
Ozone	0–500	µg/m <sup>3</sup>

The 49iQ measuring system uses ultraviolet photometry to measure ozone.

The task was to carry out performance testing in line with the applicable standards and taking into consideration the latest developments in the field.

The test was performed on the basis of the following standards:

- VDI Guideline 4202 part 1: Automated measuring systems for air quality monitoring – Performance test, declaration of suitability, and certification of point-related measuring systems for gaseous air pollutants (April 2018)
- EN 14625: Ambient air - Standard method for the measurement of the concentration of ozone by ultraviolet photometry (August 2012)

### 3. Description of the AMS tested

#### 3.1 Measuring principle

The 49 ambient air quality measuring system is a continuous ozone analyser. The instrument uses the UV absorption method as its measuring principle. It was designed for the continuous measurement of ozone in ambient air.



Figure 1: View of the 49iQ measuring system

The measuring principle applied by the 49iQ relies on the fact that ozone molecules absorb UV light of a 254 nm wavelength. The UV light intensity absorbed correlates with the ozone concentration as predicted by Lambert Beer's law.

$$\frac{I}{I_0} = e^{-KLC}$$

Where:

K is the molecular absorption coefficient;

L : is the length of the cell;

C : is the ozone concentration as ppm;

I : is the UV light intensity of the sample with ozone present;

I<sub>0</sub> : is the UV light intensity in an ozone-free sample.

The sample is drawn into the 49iQ through the sample bulkhead and is split into two gas streams. One gas stream flows through an ozone scrubber to become the reference gas (I<sub>0</sub>). The reference gas then flows to the reference solenoid valve. The sample gas (I) flows directly to the sample solenoid valve. The solenoid valves alternate the reference and sample

gas streams between cells A and B every 10 seconds. When cell A contains reference gas, cell B contains sample gas and vice versa.

The UV light intensities of each cell are measured by detectors A and B. When the solenoid valves switch the reference and sample gas streams to opposite cells, the light intensities are ignored for several seconds to allow the cells to be flushed. The 49iQ calculates the ozone concentration for each cell and outputs the average concentration to both the front panel display and the analogue outputs, and also makes the data available over the serial or Ethernet connection.

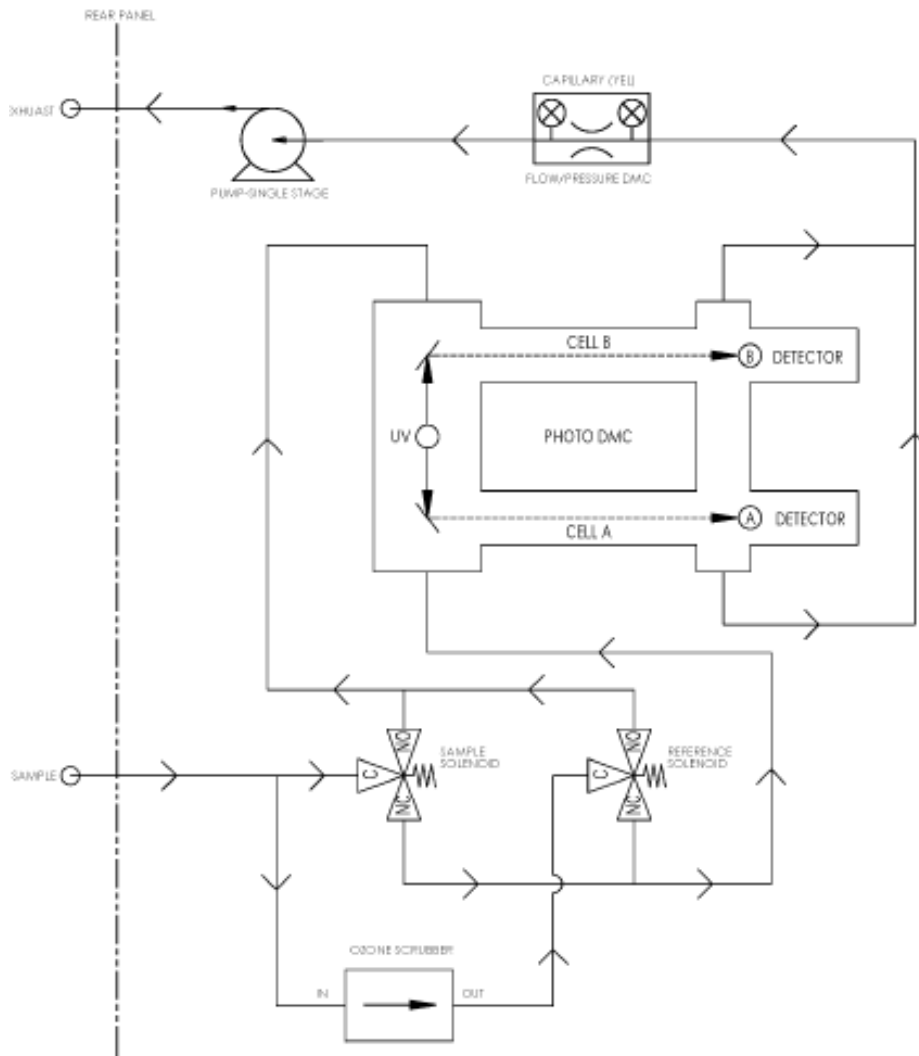


Figure 2: Flow schematic

### **3.2 AMS scope and set-up**

The 49iQ ozone analyse uses UV absorption to measure ozone. The sample to be analysed is led inside the measurement module via an external dust filter. The 49iQ system components include:

- **Photometer DMC:** The optical bench has two airtight chambers that contain the sample and reference gases with a common photometer lamp at one end and two individual detectors at the other end. The photo-diode in each detector transmits light intensity information to the DMC board for sample measurement computations. The photometer lamp power supply generates high voltage AC and contains heater control circuits for the photometer lamp.
- **Common electronics:** The common electronics contain the core computational and power routing hardware for the 49iQ, and is replicated throughout other iQ series products. It also contains front panel display, the USB ports, the Ethernet port, and the I/O interfaces. All electronics operate from a universal VDC supply. The System Controller Board (SCB) contains the main processor, power supplies, and a sub-processor, and serves as the communication hub for the instrument.
- **Peripherals Support System** The peripheral support system operates these additional devices that are needed, but do not require special feedback control or processing. The chassis fan provides air cooling of the active electronic components. Internal vacuum pump for generating air/sample through the instrument.
- **Flow/Pressure DMC** The Flow/Pressure DMC is used measure instrument pressures that assure proper flow regulation and for sample pressure within the measurement bench for pressure corrections and compensation. The DMC includes two pressure sensors.

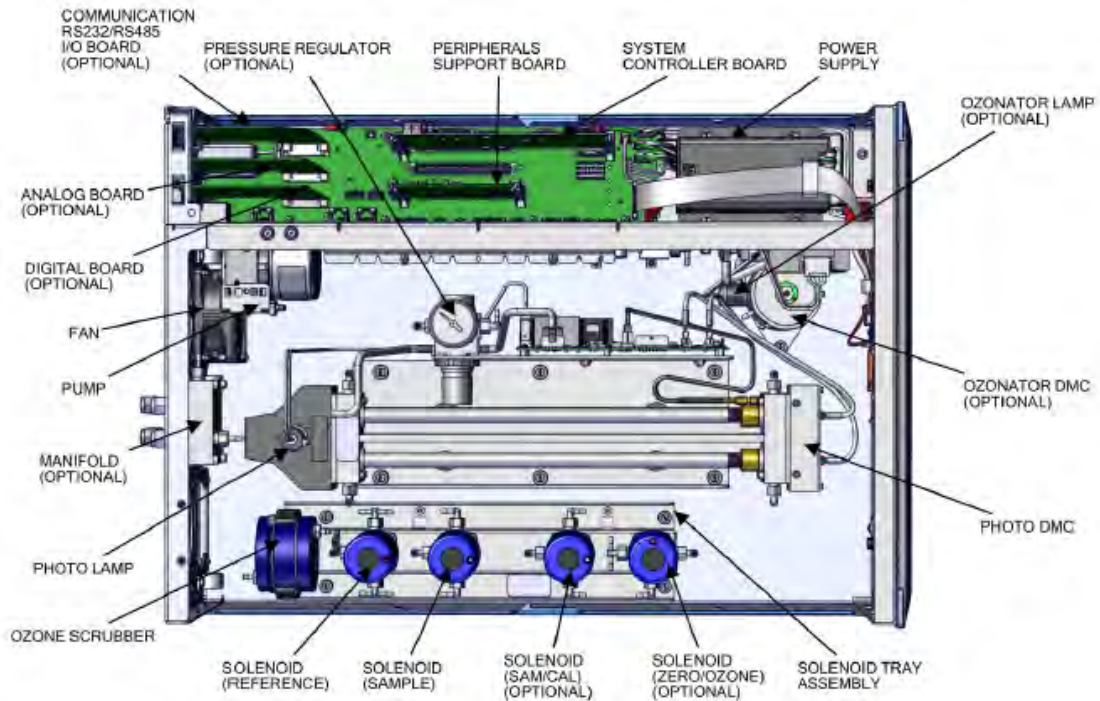


Figure 3: Inside View of the Instrument- Top View

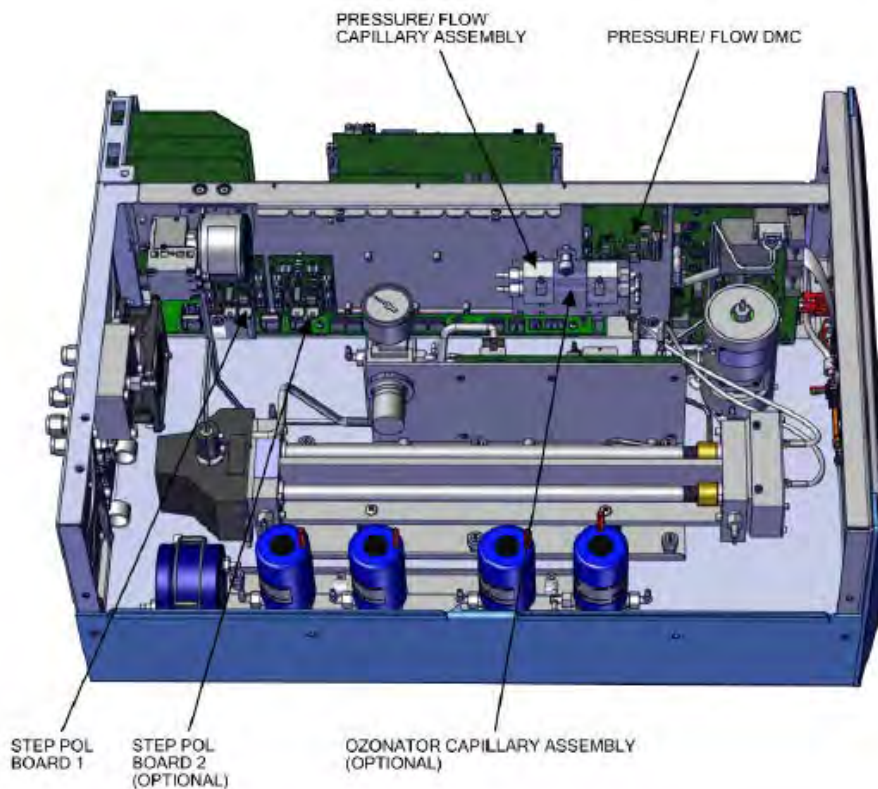


Figure 4: Inside View of the Instrument – Side View



Table 2 lists a number of important instrument characteristics of the 49iQ.

Table 2: Technical data 49iQ (manufacturer specifications)

Measured range:	Max 0–200 ppm (selectable)
Units:	ppb or $\mu\text{g}/\text{m}^3$
Measured compounds:	Ozone
Sample flow rate	~1.5 l/min (during the test)
Outputs:	<ul style="list-style-type: none"><li>• USB port (rear)</li><li>• TCP/IP Ethernet connection</li><li>• RS232</li><li>• Flash memory</li></ul>
Input voltage:	230 V or 115 V 50Hz or 60 Hz
Power:	90 W; 275 W max.
Dimension (l x w x h)	609 x 425 x 221 mm / ~ 14 kg

### 3.3 AMS adjustment

The measuring system was commissioned according to manufacturer instructions. No internal adjustment cycle was activated during performance testing. Instrument internal averaging time was 60 s.

## 4. Test programme

### 4.1 General remarks

Two identical 49iQ instruments with the following serial numbers were submitted to performance testing:

Instrument 1: SN 1180540009 and  
Instrument 2: SN 1180540010

The tests were performed with software version „1.5.1.32120“.

The test comprised a laboratory test to determine the performance characteristics as well as a field test over a period of several months.

In this report, the heading for each performance criterion cites the requirements according to the relevant standards ([1, 2, 3]) including its chapter number and wording.



Figure 5: Software version of the 49iQ instruments for testing

## 4.2 Laboratory test

The laboratory test was performed using two complete and identical systems type 49iQ, serial numbers 1180540009 and SN: 1180540010. Standards [1] and [2] specify the following test programme for the laboratory test:

- Description of instrument functions
- General requirements
- Calibration line fit
- Short-term drift
- Repeatability standard deviation
- Sensitivity to sample gas pressure
- Sensitivity to sample gas temperature
- Sensitivity to surrounding temperature
- Sensitivity to supply voltage
- Cross sensitivities
- Averaging effect
- Response time
- Difference sample/calibration inlet

Measured values were recorded using an external data logger.  
Chapters 6 and 7 summarizes the results of the laboratory tests.

## 4.3 Field test

The field test was performed between 11/06/2018 and 17/09/2018 using two identical 49iQ measuring systems. The instruments used were identical with those used for laboratory testing. The serial numbers were:

instrument 1: SN 1180540009  
instrument 2: SN 1180540010

The following test programme was determined for the field test:

- Long-term drift
- Period of unattended operation
- Availability
- Reproducibility standard deviation

Measured values were recorded using an external data logger.  
Chapters 6 and 7 summarizes the results of the field tests.

## **5. Reference Measurement Method**

### **5.1 Method of measurement**

#### **Test gases used for adjustment purposes during the test**

An ozone generator manufactured by Environics served to generate test concentrations for ozone.

The ozone generators were calibrated at the national EU Reference Laboratory for Ambient Air Quality (UBA in Langen) to verify the generated ozone concentrations. The calibration was carried out against a primary NIST standard reference photometer. The measuring principle is the ultraviolet photometric method as defined in standard EN ISO 13964 "Determination of ozone in ambient air".

Zero gas:	synthetic air
Ozone generator:	Manufacturer: Environics
Type:	6103
Serial number:	SN: 7018
Last checked on/by:	25/07/2018 / UBA Langen
	Calibration certificate No. 041-2018

## 6. Test results in accordance with VDI 4202, part 1 (2018)

### 6.1 7.3 General requirements

#### 6.1 7.3.1 Measured value display

*The measuring system shall have an operative measured value display as part of the instrument.*

### 6.2 Equipment

No additional equipment is required.

### 6.3 Testing

It was checked whether the measuring system has a measured value display.

### 6.4 Evaluation

The measuring system has an operative measured value display at the instrument front.

### 6.5 Assessment

The measuring system has an operative measured value display at the instrument front.

Criterion satisfied? yes

### 6.6 Detailed presentation of test results

Figure 6 shows the tested AMS with integrated measured value display.



Figure 6: Tested 49iQ instruments with measured value display

## **6.1 7.3.2 Calibration inlet**

*The measuring system may have a test gas inlet separate from the sample gas inlet.*

### **6.2 Equipment**

No additional equipment is required.

### **6.3 Testing**

We tested whether the instrument includes a test gas inlet separate from the sample gas inlet.

### **6.4 Evaluation**

The measuring system has a test gas inlet separate from the sample gas inlet at the instrument back.

### **6.5 Assessment**

The measuring system has a test gas inlet separate from the sample gas inlet at the instrument back.

Criterion satisfied? yes

### **6.6 Detailed presentation of test results**

Chapter

7.1 8.4.13 Difference sample/calibration port explains the functionality of the separate sample gas inlet.

## **6.1 7.3.3 Easy maintenance**

*Necessary maintenance of the measuring systems should be possible without larger effort, if possible from outside.*

## **6.2 Equipment**

No additional equipment is required.

## **6.3 Testing**

The necessary regular maintenance was performed in accordance with the instruction manual.

## **6.4 Evaluation**

The user is advised to perform the following maintenance activities:

1. Checking the operational status  
The operational status may be monitored and checked by visual inspections of the instrument's display or via an external PC connected to the AMS.
2. Checking and replacement of the external particle filter at the sample gas inlet  
The frequency at which the particle filter needs to be replaced depends on the dust concentrations in ambient air.

## **6.5 Assessment**

Maintenance takes reasonable effort and is possible with standard tools from the outside.

Criterion satisfied? yes

## **6.6 Detailed presentation of test results**

Maintenance was performed during the test in accordance with the activities and procedures described in the operation manual. Complying with the procedures described in the manual, no difficulties were identified. All maintenance activities were possible without any difficulties using standard tools.

## **6.1 7.3.4 Functional check**

*If the operation or the functional check of the measuring system require particular instruments, they shall be considered as part of the measuring system and be applied in the corresponding sub-tests and included in the assessment.*

*The performance of test gas generators, which are part of the measuring system, shall be checked by comparing it to the requirements for test gases used for continuous quality assurance. They have to provide a status signal indicating that they are ready for operation. It must be possible to control them directly or remotely.-*

## **6.2 Equipment**

Operation manual

## **6.3 Testing**

The tested measuring system does not have internal devices for operating the functional check. The current operating status of the measuring system is continuously monitored and any issues will be flagged via a series of different error messages.

The functional check of the instruments was performed using external test gases.

## **6.4 Evaluation**

The tested measuring system does not have internal devices for operating the functional check. The current operating status is continuously monitored and any issues will be flagged via a series of different error messages.

External monitoring of the zero and reference point using test gases is possible.

## **6.5 Assessment**

The tested measuring system does not have internal devices for operating the functional check.

Criterion satisfied? not applicable

## **6.6 Detailed presentation of test results**

Not applicable.



## **6.1 7.3.5 Set-up times and warm-up times**

*The set-up times and warm-up-times shall be specified in the instruction manual.*

## **6.2 Equipment**

Operation manual and additional clock

## **6.3 Testing**

The measuring systems were set up following the manufacturer's instructions. Set-up times and warm-up times were recorded separately.

Necessary constructional measures prior to the installation such as the installation of a sampling system in the analysis room were not taken into account.

## **6.4 Evaluation**

The manual does not specify the set-up time. It will of course depend on the situation given at the site of installation as well as the local voltage supply. Since the 49iQ is a compact analyser, the set-up time is mainly determined by the following tasks:

- Connecting the AMS to supply voltage;
- Connecting the tubing (sampling, discharged air).

Commissioning and changing positions in the laboratory on various occasions (installation in/removal from the climatic chamber) as well as the installation at the field test location resulted in a set-up time of ~30 minutes.

When switching the AMS on in a completely cold state, it takes about 90 minutes to reach a stable reading.

The measuring system has to be installed at a location where it is protected from weather conditions, e.g. in an air-conditioned measurement container.

## **6.5 Assessment**

Set-up times and warm-up times have been determined.

It is possible to operate the measuring system at different locations with limited effort. Set-up time is 30 minutes and warm-up time ranges between 1 and 2 hours depending on the necessary stabilisation.

Criterion satisfied? yes

## **6.6 Detailed presentation of test results**

Not applicable.

## **6.1 7.3.6 Instrument design**

*The instruction manual shall include specifications of the manufacturer regarding the design of the measuring system. The main elements are:*

*Instrument shape (e.g. bench mounting, rack mounting, free mounting)*

*Mounting position (e.g. horizontal or vertical mounting)*

*Safety requirements*

*Dimensions*

*Weight*

*Power consumption*

*Preventing condensation within the analyser.*

## **6.2 Equipment**

Operation manual and a measuring system for recording energy consumption (Gossen Metrawatt) and scales.

## **6.3 Testing**

The instrument design of the measuring systems handed over for testing was compared to the description provided in the manual. The energy consumption specified was verified during normal operation in the field test.

## **6.4 Evaluation**

The measuring system is intended for horizontal mounting (e.g. on a table or in a rack) sheltered from weather conditions. The temperature at the site of installation must be between 0 °C and 30 °C.

The dimensions and weight of the measuring system correspond to the information provided in the operation manual.

The manufacturer specifies a maximum power consumption of 275 W. During start-up (warm-up) a short-term consumption of 250 W was recorded. During normal operation, energy consumption is 90 W.

## **6.5 Assessment**

Specifications made in the instruction manual concerning instrument design are complete and correct.

Criterion satisfied? yes

## **6.6 Detailed presentation of test results**

Not required for this performance criterion

## **6.1 7.3.7 Unintended adjustment**

*It shall be possible to secure the adjustment of the measuring system against illicit or unintended adjustment during operation. Alternatively, the user manual shall specifically note that the measuring system may only be installed in a secured area.*

### **6.2 Equipment**

The test of this criterion did not require any further equipment.

### **6.3 Testing**

The measuring system can be operated via a display at its front with touch panel or via a PC connected to the measuring system directly or via a network.

The instrument provides an internal feature (password protection) to secure it against illicit or unintended adjustment. It is only possible to change parameters or adjust the measuring system after entering the password.

### **6.4 Evaluation**

On entering the correct password, it is possible to change instrument parameters affecting measurement characteristics via the control panel and via an external computer.

### **6.5 Assessment**

The measuring system is secured against unintended and unauthorised adjustment of instrument parameters by way of a password.

Criterion satisfied? yes

### **6.6 Detailed presentation of test results**

Not required for this performance criterion

## **6.1 7.3.8 Data output**

*The output signal shall be provided digitally and/or as analogue signals (e.g. 4 mA to 20 mA).*

## **6.2 Equipment**

Analogue Yokogawa data logger, PC

## **6.3 Testing**

The measuring system provides the following transmission routes: Modbus, RS232, RS485, USB, digital outputs, TCP/IP network. Moreover, the measuring system also provides an option to output analogue signals (V or mA).

## **6.4 Evaluation**

Measured signals are displayed on the back of the instrument as follows:

Output: 0–20 mA, 4–20 mA or 0–1 V, 0–10 V, selectable concentration range

Digital: Modbus, RS232, RS485, USB, digital inputs and outputs, TCP/IP network

## **6.5 Assessment**

Measured signals are provided as analogue (0–20 mA, 4–20 mA or 0–1 V, 0–10 V) and digital signals (via TCP/IP, RS 232, USB).

The instrument provides additional interfaces (e.g. analogue outputs) for connecting additional measuring or other peripheral instruments.

Criterion satisfied? yes

## **6.6 Detailed presentation of test results**

Not required for this performance criterion

## 6.1 7.3.9 Digital interface

*The digital interface shall allow the transmission of output signals, status signals, and information like instrument type, measurement range, and measured component and unit. The digital interface shall be described fully in respective standards and guidelines.*

*Access to the measuring system via digital interfaces, e.g. for data transmission, shall be secured against unauthorised access, e.g. by a password.*

## 6.2 Equipment

PC

## 6.3 Testing

The measuring system provides the following transmission routes: Modbus, RS232, RS485, USB, 10 digital outputs, TCP/IP network. Moreover, the measuring system also provides an option to output analogue signals (V or mA).

## 6.4 Evaluation

Digital measured signals are provided as follows:

Modbus, RS232, RS485, USB, TCP/IP network

Digital output signals were checked. All relevant pieces of information such as measured signals, status signals, measured component, measuring range, unit and instrument information can be transmitted digitally.

Digital data retrieval always requires entry of the correct password.

## 6.5 Assessment

Digital transmission of measured values operates correctly.

Criterion satisfied? yes

## 6.6 Detailed presentation of test results

Not required for this performance criterion

## **6.1 Data transmission protocol**

*The measuring system shall contain at minimum one data transmission protocol for the digital transmission of the output signal.*

*Every data transmission protocol provided by the manufacturer for the measuring system shall allow the correct transmission of the data and detect errors in the transmission. The data transmission protocol including the used commands is to be documented in the instruction manual. The data transmission protocol shall allow to transmit at minimum the following data:*

*identification of the measuring system*

*identification of measured components*

*Unit*

*output signal with time signature (date and time)*

*operation and error status*

*operating commands for remote control of the measuring systems*

*All data are to be transmitted as clear text (ASCII characters).*

## **6.2 Equipment**

A PC

## **6.3 Testing**

By default, the measuring system comes with an installed Modbus protocol.

## **6.4 Evaluation**

By default, the measuring system comes with an installed Modbus protocol. Measured and status signals are transmitted correctly.

## **6.5 Assessment**

By default, the measuring system comes with an installed Modbus protocol. Measured and status signals are transmitted correctly. Customers of Thermo Fisher Scientific can look up commands on the internet.

Criterion satisfied? yes

## **6.6 Detailed presentation of test results**

Not required for this performance criterion

## 6.1 7.3.11 Measuring range

*The upper limit of measurement of the measuring systems shall be greater or equal to the upper limit of the certification range.*

## 6.2 Equipment

The test of this criterion did not require any further equipment.

## 6.3 Testing

We compared the upper limit of measurement to the upper limit of the certification range to verify whether the former was larger or equal to the latter.

## 6.4 Evaluation

In theory, it is possible to set the measuring system to measuring ranges of up to 0–200 ppm.

Possible measuring range: 200 ppm  
Upper limit of the certification range for ozone: 500 µg/m<sup>3</sup> (250 ppb)

## 6.5 Assessment

The default measuring range is set to 0–250 ppb (500 µg/m<sup>3</sup>) for ozone. Supplementary measuring ranges up to 0–200 ppm are possible.

The measuring system's upper limit of measurement exceeds the upper limit of the certification range in each case.

Criterion satisfied? yes

## 6.6 Detailed presentation of test results

VDI standard 4202, part 1 and standard EN 14625 define the following minimum requirements for the certification ranges of continuous air quality monitoring systems for ozone:

Table 3: Certification ranges VDI 4202-1 and EN 14625

Measured components:	CR lower limit	CR upper limit	Limit value (alert threshold)	Evaluation period
	in µg/m <sup>3</sup>	in µg/m <sup>3</sup>	in µg/m <sup>3</sup>	
Ozone	0	500	240	1 h

## **6.1 7.3.12 Negative output signals**

*Negative output signals or measured values may not be suppressed (life zero).*

### **6.2 Equipment**

The test of this criterion did not require any further equipment.

### **6.3 Testing**

The possibility of displaying negative signals was tested both in the laboratory and in the field test.

### **6.4 Evaluation**

The AMS displays negative values.

### **6.5 Assessment**

The measuring system also provides negative output signals.

Criterion satisfied? yes

### **6.6 Detailed presentation of test results**

Not applicable.



## 6.1 7.3.13 Failure in the mains voltage

*In case of malfunction of the measuring system or failure in the mains voltage uncontrolled emission of operation and calibration gas shall be avoided. The measurement parameters shall be secured by buffering against loss caused by failure in the mains voltage. When mains voltage returns, the instrument shall automatically reach the operation mode and start the measurement according to the operating instructions.*

### 6.2 Equipment

Not required for this performance criterion

### 6.3 Testing

A simulated failure in the mains voltage served to test whether the instrument remained fully functional and reached operation mode on return of the mains voltage.

### 6.4 Evaluation

Since the measuring systems do not rely on operation and calibration gases, uncontrolled emission of gases is not possible.

Once the measuring system resumes operation after a power failure it is in warm-up mode until it reaches an appropriate operating temperature again. How long it will take up to fully warm up again will depend on the ambient conditions and the temperature of the system when switching it back on again. After completion of the warm-up phase, the measuring system will switch back automatically into the mode which had been active before the failure in mains voltage. The warm-up phase is signalled via various temperature alerts.

### 6.5 Assessment

On return of mains voltage, the instrument returns to normal operating mode and automatically resumes measuring.

Criterion satisfied? yes

### 6.6 Detailed presentation of test results

Not applicable.

## **6.1 7.3.14 Operating states**

*The measuring system shall allow the control of important operating states by telemetrically transmitted status signals.*

## **6.2 Equipment**

Computer for data acquisition

## **6.3 Testing**

The measuring system possesses various interfaces such as RS232, USB, digital and analogue inputs and outputs, TCP/IP network. A simple connection can be established between the analyser (49iQ) and an external computer via a web browser. This enables telemetrically transferring data, adjusting configurations and displaying the analyser reading on the computer screen. In this mode it is possible to access and operate all the information and features from the analyser display via the computer. Moreover, "remote operation" provides a useful tool for checking instrument operational and parameter values.

## **6.4 Evaluation**

The measuring system allows for comprehensive monitoring and control via various connectors.

## **6.5 Assessment**

The measuring system provides various ports to ensure comprehensive monitoring and control via an external computer.

Criterion satisfied? yes

## **6.6 Detailed presentation of test results**

Not applicable.

## **6.1 7.3.15 Switch-over**

*Switch-over between measurement and functional check and/or calibration shall be possible telemetrically by computer control or manual intervention.*

## **6.2 Equipment**

Not required for this performance criterion

## **6.3 Testing**

It is possible to monitor and control the AMS on the instrument itself or telemetrically.

## **6.4 Evaluation**

All operating procedures which do not require on-site practical handling may be performed both by the operator on the instrument itself or telemetrically.

## **6.5 Assessment**

In principle, it is possible to monitor all tasks necessary for a functional check on the instrument itself or telemetrically.

Criterion satisfied? yes

## **6.6 Detailed presentation of test results**

Not applicable.

## **6.1 7.3.16 Instrument software**

*The measuring system shall be able to display the version of the instrument software.*

### **6.2 Equipment**

Not required for this performance criterion

### **6.3 Testing**

It was tested whether the software version can be displayed on the instrument. The AMS manufacturer was informed of his obligation to communicate any changes to the instrument software to the test laboratory.

### **6.4 Evaluation**

The current software version is displayed when switching on the instrument. Furthermore, it can be accessed via menu item "configuration" at any time.

The tests were performed with software version "1.5.1. 32120".

### **6.5 Assessment**

The instrument's software version is displayed. Software changes are communicated to the test laboratory.

Criterion satisfied? yes

### **6.6 Detailed presentation of test results**

Figure 5 shows the software version displayed by the measuring system.

## **6.1 7.4 Requirements on performance characteristics for laboratory testing**

### **6.1 7.4.1 General requirements**

*The performance characteristics which shall be determined during testing in the laboratory and their related performance criteria for measured components according to 39. BImSchV are given in Table A1 of VDI 4202-1.*

*The certification range for other components is to be defined. Performance criteria are to be defined by drawing from Table A1. These definitions shall be cleared with the relevant body before testing.*

*The determination of the performance characteristics shall be done according to the procedures de-scribed in Section 8.4.*

### **6.2 Equipment**

Not required for this performance criterion

### **6.3 Testing**

Tests were performed using the performance characteristics specified in VDI standard 4202, part 1 (2018) and standard EN 14625.

### **6.4 Evaluation**

Not applicable.

### **6.5 Assessment**

Tests were performed using the performance characteristics specified in VDI standard 4202, part 1 (2018) and standard EN 14625 (2012)

Criterion satisfied? yes

### **6.6 Detailed presentation of test results**

Not applicable.

## 6.1 7.4.2 Test requirements

*Before operating the measuring system, the instruction manual of the manufacturer shall be followed particularly with regard to the set-up of equipment and the quality and quantity of the consumable supplies necessary.*

*The measuring system shall be allowed to warm up for the duration specified by the manufacturer before undertaking any tests. If the warm-up time is not specified, a minimum of 4 h applies.*

*If auto-scale or self-correction functions are arbitrary, these functions shall be turned off during the laboratory test.*

*If auto-scale or self-correction functions are not arbitrary but treated as “normal operating conditions”, times and values of the self-correction shall be available for the test laboratory. The values of the auto-zero and auto-drift corrections are subject to the same restrictions as given in the performance characteristics.*

*Before applying test gases to the measuring system, the test gas system shall have been operated for a sufficiently long time in order to stabilize the concentrations applied to the measuring system. The measuring system shall be tested using an implemented particle filter.*

*Most measuring systems are able to display the output signal as running average of an adjustable period. Some measuring systems adjust the integration time as a function of the frequency of the fluctuations of the concentration of the measured component automatically. These options are typically used for equalisation of the output data. It does not have to be proved that the selected value for the averaging period or the use of an active filter affects the result of testing the averaging period and the response time.*

*The adjustments of the measuring system shall meet the specifications of the manufacturer. All adjustments are to be documented in the test report.*

*For the determination of the various performance characteristics, suitable zero and test gases shall be used.*

*Parameters: During the test for each individual performance characteristic, the values of the following parameters shall be stable within the specified range given in Table 3 of standard VDI 4202-1.*

*Test gas: For the determination of the various performance characteristics, test gases traceable to national or international standards shall be used.*

## 6.2 Equipment

Not required for this performance criterion

## 6.3 Testing

Tests were performed using the performance characteristics specified in VDI standard 4202, part 1 (2018) and standard EN 14625 (2012).

## 6.4 Evaluation

The warm-up time described in the manual was observed.

Neither auto-scale nor self-correction functions were activated during the laboratory test.

The system for test gas application ran smoothly; tests were performed with the internal upstream particle filters.

The averaging time was set to 60 s for testing. No equalisation filters were activated.  
Test gases used comply with the requirements of VDI 4202-1.

### **6.5 Assessment**

Tests were performed using the performance characteristics specified in VDI standard 4202, part 1 (2018) and standard EN 14625 (2012)

Criterion satisfied? yes

### **6.6 Detailed presentation of test results**

Not applicable.

## **6.1 7.4.3 Response time and memory effect**

*The response time (rise) of the measuring system shall not exceed 180 s.*

*The response time (fall) of the measuring system shall not exceed 180 s.*

*The difference between the response time (rise) and response time (fall) of the measuring system shall not exceed 10% of response time (rise) or 10 s, whatever value is larger.*

## **6.2 Equipment**

Not applicable

## **6.3 Testing**

Determination and evaluation of the response time corresponds exactly to determining the response time in accordance with standard EN 14625 (2012). The reader is therefore referred to chapter 7.1 8.4.3 Response time.

## **6.4 Evaluation**

See chapter 7.1 8.4.3 Response time

## **6.5 Assessment**

See chapter 7.1 8.4.3 Response time

Criterion satisfied? yes

## **6.6 Detailed presentation of test results**

Not applicable in this instance.



## **6.1**      **7.4.4 Short-term drift**

*The short-term drift at zero point shall not exceed 2.0 nmol/mol.  
The short-term drift at reference point shall not exceed 6.0 nmol/mol.*

## **6.2**      **Equipment**

Not applicable

## **6.3**      **Testing**

Determination and evaluation of the short-term drift corresponds exactly to determining the short term drift in accordance with standard EN 14625 (2012). The reader is therefore referred to chapter 7.1    8.4.4 Short-term drift.

## **6.4**      **Evaluation**

See chapter 7.1    8.4.4 Short-term drift

## **6.5**      **Assessment**

See chapter 7.1    8.4.4 Short-term drift

Criterion satisfied?    yes

## **6.6**      **Detailed presentation of test results**

Not applicable in this instance.

## **6.1 7.4.5 Repeatability standard deviation**

*The repeatability standard deviation at zero point shall be  $\leq 1.0$  nmol/mol of the upper limit of the certification range.*

*The repeatability standard deviation at reference point shall not exceed 3.0 nmol/mol.*

## **6.2 Equipment**

Not applicable

## **6.3 Testing**

Performing and evaluating the repeatability standard deviation at zero point corresponds exactly to determining the repeatability standard deviation in accordance with standard EN 14625 (2012). The reader is therefore referred to chapter 7.1 8.4.5 Repeatability standard deviation.

## **6.4 Evaluation**

See chapter 7.1 8.4.5 Repeatability standard deviation.

## **6.5 Assessment**

See chapter 7.1 8.4.5 Repeatability standard deviation

Criterion satisfied? yes

## **6.6 Detailed presentation of test results**

Not applicable in this instance.

## **6.1**      **7.4.6 Linearity**

*The analytical function describing the relationship between the measured values and the desired values shall be linear. Reliable linearity is  
The deviation from the linearity of the calibration function at zero shall not exceed 5 nmol/mol. At concentrations above zero, it shall not exceed 4% of the measured value.*

## **6.2**      **Equipment**

Not applicable

## **6.3**      **Testing**

Performing and evaluating the linearity corresponds exactly to determining the lack of fit in accordance with standard EN 14625 (2012). The reader is therefore referred to chapter 7.1  
8.4.6 Lack of fit of linearity of the calibration function.

## **6.4**      **Evaluation**

See chapter 7.1      8.4.6 Lack of fit of linearity of the calibration function.

## **6.5**      **Assessment**

See chapter 7.1      8.4.6 Lack of fit of linearity of the calibration function.

Criterion satisfied?    yes

## **6.6**      **Detailed presentation of test results**

Not applicable in this instance.

## **6.1 7.4.7 Sensitivity coefficient to sample gas pressure**

*The sensitivity coefficient of sample gas pressure at reference point shall not exceed 2.0 (nmol/mol)/kPA.*

### **6.2 Equipment**

Not applicable

### **6.3 Testing**

Performing and evaluating the sensitivity coefficient of sample gas pressure corresponds exactly to determining the sensitivity coefficient to sample gas pressure in accordance with standard EN 14625 (2012). The reader is therefore referred to chapter 7.1 8.4.7 Sensitivity coefficient to sample gas pressure.

### **6.4 Evaluation**

See chapter 7.1 8.4.7 Sensitivity coefficient to sample gas pressure

### **6.5 Assessment**

See chapter 7.1 8.4.7 Sensitivity coefficient to sample gas pressure  
Criterion satisfied? yes

### **6.6 Detailed presentation of test results**

Not applicable in this instance.

## **6.1 7.4.8 Sensitivity coefficient to sample gas temperature**

*The sensitivity coefficient of sample gas temperature shall not exceed 1.0 (nmol/mol)/kPA.*

### **6.2 Equipment**

Not applicable

### **6.3 Testing**

Performing and evaluating the sensitivity coefficient of sample gas temperature corresponds exactly to determining the sensitivity coefficient to sample gas temperature in accordance with standard EN 14625 (2012). The reader is therefore referred to chapter 8.4.8 Sensitivity coefficient to sample gas temperature.

### **6.4 Evaluation**

See chapter 8.4.8 Sensitivity coefficient to sample gas temperature

### **6.5 Assessment**

See chapter 8.4.8 Sensitivity coefficient to sample gas temperature

Criterion satisfied? yes

### **6.6 Detailed presentation of test results**

Not applicable in this instance.

## **6.1 7.4.9 Sensitivity coefficient to surrounding temperature**

*The sensitivity coefficient of surrounding temperature shall not exceed 1.0 (nmol/mol)/kPA.*

### **6.2 Equipment**

Not applicable

### **6.3 Testing**

Performing and evaluating the sensitivity coefficient of surrounding temperature corresponds exactly to determining the sensitivity coefficient to the surrounding temperature in accordance with standard EN 14625 (2012). The reader is therefore referred to chapter 7.1 8.4.9 Sensitivity coefficient to surrounding temperature.

### **6.4 Evaluation**

See chapter 7.1 8.4.9 Sensitivity coefficient to surrounding temperature

### **6.5 Assessment**

See chapter 7.1 8.4.9 Sensitivity coefficient to surrounding temperature  
Criterion satisfied? yes

### **6.6 Detailed presentation of test results**

Not applicable in this instance.

## **6.1 7.4.10 Sensitivity coefficient to electrical voltage**

*The sensitivity coefficient of electrical voltage shall not exceed 0.3 (nmol/mol)/V.*

## **6.2 Equipment**

Not applicable

## **6.3 Testing**

Performing and evaluating the sensitivity coefficient of electrical voltage corresponds exactly to determining the sensitivity coefficient to electrical voltage in accordance with standard EN 14625 (2012). The reader is therefore referred to chapter 7.1 8.4.10 Sensitivity coefficient to electrical voltage.

## **6.4 Evaluation**

See chapter 7.1 8.4.10 Sensitivity coefficient to electrical voltage

## **6.5 Assessment**

See chapter 7.1 8.4.10 Sensitivity coefficient to electrical voltage  
Criterion satisfied? yes

## **6.6 Detailed presentation of test results**

Not applicable in this instance.

## **6.1 7.4.11 Cross sensitivity**

*The change in the measured value caused by interfering components in the sample gas shall not exceed the requirements of Table A of VDI 4202, part 1 (April 2018), at zero and reference point.*

*For measuring principles deviating from EN standards the absolute values of the sum of the positive and the sum of negative deviations caused by interfering components in the sample gas shall not exceed 3% of the upper limit of the certification range at zero and reference point. A value  $c_i$  at 70% to 80% of the upper limit of the certification range shall be used as reference point.*

## **6.2 Equipment**

Not applicable

## **6.3 Testing**

Performing and evaluating cross sensitivity corresponds exactly to determining interferences in accordance with standard EN 14625 (2012). The reader is therefore referred to chapter 7.1

8.4.11 Interferences

## **6.4 Evaluation**

See chapter 7.1 8.4.11 Interferences

## **6.5 Assessment**

See chapter 7.1 8.4.11 Interferences

Criterion satisfied? yes

## **6.6 Detailed presentation of test results**

Not applicable in this instance.



## 6.1 7.4.12 Averaging effect

*The measuring system shall enable hourly averages.*

*The averaging effect shall not exceed 7% of the measured value.*

## 6.2 Equipment

Not applicable

## 6.3 Testing

Performing and evaluating the averaging effect corresponds exactly to determining the averaging test in accordance with standard EN 14625 (2012).

However, VDI 4202-1 (2018) requires concentrations between zero and 200 nmol/mol ozone to be applied for determining the averaging effect. By contrast, EN 14625 (2012) specifies concentrations between 0 and  $c_t$  (1h alert threshold = 120 nmol/mol) to be applied for determining the averaging effect. For the sake of clarity and ease of comparison with previously-approved instruments, this test was performed in accordance with the specifications of standard EN 14625. Moreover, the value determined is closer to ozone levels typically measured in central Europe. The reader is therefore referred to chapter 7.1 8.4.12 Averaging test.

## 6.4 Evaluation

See Chapter 6.1 7.4.12 Averaging effect.

## 6.5 Assessment

See Chapter 6.1 7.4.12 Averaging effect.

Criterion satisfied? yes

## 6.6 Detailed presentation of test results

Not applicable in this instance.

## **6.1 7.4.13 Difference between sample and calibration port**

*If a measuring system, standardly or optionally, possesses a test gas inlet separated from the sample gas inlet, this configuration shall be tested.*

*The difference between the measured values obtained by feeding gas at the sample gas and test gas inlet shall not exceed 1 %.*

## **6.2 Equipment**

Not applicable

## **6.3 Testing**

Determination and evaluation of the difference between sample and calibration port corresponds exactly to determining the difference sample/calibration port in accordance with standard EN 14625 (2012). The reader is therefore referred to chapter 7.1 8.4.13 Difference sample/calibration port.

## **6.4 Evaluation**

See chapter 7.1 8.4.13 Difference sample/calibration port

## **6.5 Assessment**

See chapter 7.1 8.4.13 Difference sample/calibration port  
Criterion satisfied? yes

## **6.6 Detailed presentation of test results**

Not applicable in this instance.

**6.1**      **7.4.14 Converter efficiency**

*In case of measuring systems with a converter, the converter efficiency shall be at least 98 % in the laboratory test.*

**6.2**      **Equipment**

Not applicable

**6.3**      **Testing**

The tested measuring system does not have a converter.

**6.4**      **Evaluation**

Not applicable.

**6.5**      **Assessment**

Not applicable since the measuring system does not have a converter.

Criterion satisfied? Not applicable

**6.6**      **Detailed presentation of test results**

Not applicable in this instance.

## **6.1 7.4.15 Residence time in the analyser**

*If the residence time has influence on the output signal, like for NO<sub>x</sub> and ozone measuring systems, it is necessary to calculate the residence time from the volume flow and the volume of the gas lines and other relevant components of the measuring system and the particle filter casing.*

*In the case of NO<sub>x</sub> and O<sub>3</sub> measurements, the residence time shall not exceed 3 s.*

## **6.2 Equipment**

Not applicable

## **6.3 Testing**

Performing and evaluating the averaging effect corresponds exactly to determining the averaging test in accordance with standard EN 14625 (2012). This is why we refer to Chapter 7.1 8.4.14 Residence time in the analyser.

## **6.4 Evaluation**

See chapter 7.1 8.4.14 Residence time in the analyser

## **6.5 Assessment**

See chapter 7.1 8.4.14

Criterion satisfied? yes

## **6.6 Detailed presentation of test results**

Not applicable in this instance.

## **6.1 7.5 Requirements on performance characteristics for testing in the field**

### **6.1 7.5.1 General requirements**

*The performance characteristics which shall be determined during testing in the field and their related performance criteria for measured components according to 39. BImSchV are given in Table A1 of VDI 4202-1 (2018).*

*The certification range for other components is to be defined. Performance criteria are to be defined by drawing from Table A1 of VDI 4202-1 (2018) These definitions shall be cleared with the relevant body before testing.*

*The determination of the performance characteristics shall be done according to the procedures de-scribed in Section 8.5 of VDI 4202-1 (2018).*

### **6.2 Equipment**

Not required for this performance criterion

### **6.3 Testing**

Tests were performed using the performance characteristics specified in VDI standard 4202, part 1 (2018) and standard EN 14625 (2012).

### **6.4 Evaluation**

Not applicable.

### **6.5 Assessment**

Tests were performed using the performance characteristics specified in VDI standard 4202, part 1 (2018) and standard EN 14625 (2012)

Criterion satisfied? yes

### **6.6 Detailed presentation of test results**

Not applicable.

## **6.1 7.5.2 Location for the field test**

*The monitoring station for the field test is to be chosen according to the requirements of 39. BImSchV such that the expected concentrations of the measured components to be measured correspond to the designated task. The equipment of the monitoring station shall allow the implementation of the field test and shall fulfil all requirements considered to be necessary during measurement planning.*

## **6.2 Equipment**

Not required for this performance criterion

## **6.3 Testing**

The field test location was selected in compliance with the 39<sup>th</sup> BImSchV.

## **6.4 Evaluation**

The field test location was selected in compliance with the 39<sup>th</sup> BImSchV. The measuring station for the field test was located at a car park on the premises of TÜV Rheinland.

## **6.5 Assessment**

The field test location was selected in compliance with the 39<sup>th</sup> BImSchV.

Criterion satisfied? yes

## **6.6 Detailed presentation of test results**

Not applicable.

## 6.1 7.5.3 Test requirements

*The measuring systems shall be installed in the monitoring station and, after connecting to the existing or separate sampling system, activated properly.*

*The adjustments of the measuring system shall meet the specifications of the manufacturer. All adjustments are to be documented in the test report.*

*The measuring systems shall be maintained during the field test, following the manufacturer's specifications, and shall be checked with suitable test gases regularly.*

*If the measuring system contains auto-scale or self-correction functions and they are treated as "normal operating conditions", these functions shall be turned on during the field test. Values of the self-correction shall be available to the test laboratory. The values of the auto-zero and auto-drift corrections for the inspection interval (long-term drift) are subject to the same restrictions as given in the performance characteristics.*

## 6.2 Equipment

Not required for this performance criterion

## 6.3 Testing

For the purpose of field testing, the measuring system was mounted in a measuring station and connected to the existing sampling system. The measuring system was then commissioned following the manufacturer's instructions in the manual.

Neither self-correction nor auto-zero functions were activated during the field test.

## 6.4 Evaluation

During the field test, the measuring system was operated and serviced according to the manufacturer's instructions. Neither self-correction nor auto-zero functions were activated.

## 6.5 Assessment

During the field test, the measuring system was operated and serviced according to the manufacturer's instructions.

Criterion satisfied? yes

## 6.6 Detailed presentation of test results

Not applicable.

## **6.1 7.5.4 Long-term drift**

*The long-term drift at zero point shall not exceed 5.0 nmol/mol.*

*The long-term drift at reference point shall not exceed 5 % of the upper limit of the certification range.*

## **6.2 Equipment**

Not applicable

## **6.3 Testing**

Determination and evaluation of the long-term drift corresponds exactly to determining the long term drift in accordance with standard EN 14625 (2012). The reader is therefore referred to chapter 7.1 8.5.4 Long-term drift.

## **6.4 Evaluation**

See chapter 7.1 8.5.4 Long-term drift.

## **6.5 Assessment**

See chapter 7.1 8.5.4 Long-term drift.

Criterion satisfied? yes

## **6.6 Detailed presentation of test results**

Not applicable in this instance.



## **6.1 7.5.5 Reproducibility standard deviation under field conditions**

*The standard deviation from paired measurements under field conditions shall be determined with two identical measuring systems by paired measurements in the field test.*

*The standard deviation under field conditions shall not exceed 5% of the mean value over a period of three months.*

## **6.2 Equipment**

Not applicable

## **6.3 Testing**

Performing and evaluating the standard deviation from paired measurements corresponds exactly to determining the reproducibility standard deviation in accordance with standard EN 14625 (2012). The reader is therefore referred to Chapter 7.1 8.5.5 Reproducibility standard deviation or ozone under field conditions.

## **6.4 Evaluation**

See Chapter 7.1 8.5.5 Reproducibility standard deviation or ozone under field conditions

## **6.5 Assessment**

See Chapter 7.1 8.5.5 Reproducibility standard deviation or ozone under field conditions  
Criterion satisfied? yes

## **6.6 Detailed presentation of test results**

Not applicable in this instance.

## **6.1 7.5.6 Inspection interval**

*The inspection interval of the measuring system shall be determined during the field test and specified. The maintenance interval should be three months, if possible, but at least two weeks.*

## **6.2 Equipment**

Not required for this performance criterion

## **6.3 Testing**

Performing and evaluating the inspection interval corresponds exactly to determining the period of unattended operation in accordance with standard EN 14625 (2012). The reader is therefore referred to chapter 7.1 8.5.6 Inspection interval.

## **6.4 Evaluation**

See chapter 7.1 8.5.6 Inspection interval.

## **6.5 Assessment**

See chapter 7.1 8.5.6 Inspection interval.

Criterion satisfied? yes

## **6.6 Detailed presentation of test results**

Not applicable in this instance.

## **6.1**      **7.5.7 Availability**

*The availability of the measuring system shall be determined during the field test and shall be at least 95%.*

## **6.2**      **Equipment**

Not applicable

## **6.3**      **Testing**

Determination and evaluation of the availability corresponds exactly to determining the period of availability of the analyser in accordance with standard EN 14625 (2012). This is why we refer to Chapter 7.1      8.5.7 Period of availability of the analyser.

## **6.4**      **Evaluation**

See Chapter 7.1      8.5.7 Period of availability of the analyser

## **6.5**      **Assessment**

See Chapter 7.1      8.5.7 Period of availability of the analyser

Criterion satisfied?    yes

## **6.6**      **Detailed presentation of test results**

Not applicable in this instance.

**6.1**      **7.5.8 Converter efficiency**

*At the end of the field test, the converter efficiency shall be at least 95 %.*

**6.2**      **Equipment**

Not applicable

**6.3**      **Testing**

The tested measuring system does not have a converter.

**6.4**      **Evaluation**

Not applicable.

**6.5**      **Assessment**

Not applicable since the measuring system does not have a converter.

Criterion satisfied? not applicable

**6.6**      **Detailed presentation of test results**

Not applicable in this instance.

## 6.1 7.6 Type approval and calculation of the measurement uncertainty

*The type approval of the measuring system requires the following:*

- 1) *The value of each individual performance characteristic tested in the laboratory shall fulfil the criterion stated in Table C1 of VDI 4202-1 (2018).*
- 2) *The expanded uncertainty calculated from the standard uncertainties due to the values of the specific performance characteristics obtained in the laboratory tests shall fulfil the criterion as stated Table C1 of VDI 4202-1 (2018). This criterion is the maximum uncertainty of individual measurements for continuous measurements at the 1-hour limit value. The relevant specific performance characteristics and the calculation procedure are given in Annex F.*
- 3) *The value of each individual performance characteristic tested in the laboratory shall fulfil the criterion stated in Table A1 of VDI 4202-1 (2018).*
- 4) *The expanded uncertainty calculated from the standard uncertainties due to the values of the specific performance characteristics obtained in the laboratory and field tests shall fulfil the criterion as stated Table C1 of VDI 4202-1 (2018). This criterion is the maximum uncertainty of individual measurements for continuous measurements at the 1-hour limit value. The relevant specific performance characteristics and the calculation procedure are given in Annex F.*

## 6.2 Equipment

Not applicable

## 6.3 Testing

Uncertainty calculation was performed in line with standard EN 14625 (2012) and is presented in 7.1 8.6 Calculation of the total uncertainty according to EN 14625 (2012)

## 6.4 Evaluation

Uncertainty calculation was performed in line with standard EN 14625 (2012) and is presented in 7.1 8.6 Calculation of the total uncertainty according to EN 14625 (2012)

## 6.5 Assessment

Uncertainty calculation was performed in line with standard EN 14625 (2012) and is presented in 7.1 8.6 Calculation of the total uncertainty according to EN 14625 (2012) according to Annex E of EN 14625 (2012)

Criterion satisfied? yes

## 6.6 Detailed presentation of test results

Not applicable in this instance.

## 7. Test Results in accordance with Standard EN 14625 (2012)

### 7.1 8.4.3 Response time

*Rise and fall response time ≤ 180 s each. Difference between rise and fall response time ≤ 10 s.*

### 7.2 Testing

The determination of the response time shall be carried out by applying to the analyser a step function in the concentration from less than 20 % to about 80 % of the maximum of the certification range of NO and vice versa.

The change from zero gas to span gas and vice versa needs to be made almost instantaneously, with the use of a suitable valve. The valve outlet shall be mounted direct to the inlet of the analyser, and both zero gas and span gas shall have the same amount of gas in excess, which is vented by the use of a tee. The gas flows of both zero gas and span gas shall be chosen in such a way that the dead time in the valve and tee can be neglected compared to the lag time of the analyser system. The step change is made by switching the valve from zero gas to span gas. This event needs to be timed and is the start ( $t = 0$ ) of the (rise) lag time for the dead time (rise) as shown in Figure 7. When the reading shows 98% of the applied concentration, the span gas can be changed to zero gas again; this event is the start ( $t = 0$ ) of the (fall) lag time. When the reading shows 2% of the applied concentration, the whole cycle as shown in Figure 7 is complete.

The elapsed time (response time) between the start of the step change and reaching 90% of the analyser final stable reading of the applied concentration shall be measured. The whole cycle shall be repeated four times. The average of the four response times (rise) and the average of the four response times (fall) shall be calculated.

The difference in response times shall be calculated according to: Where:

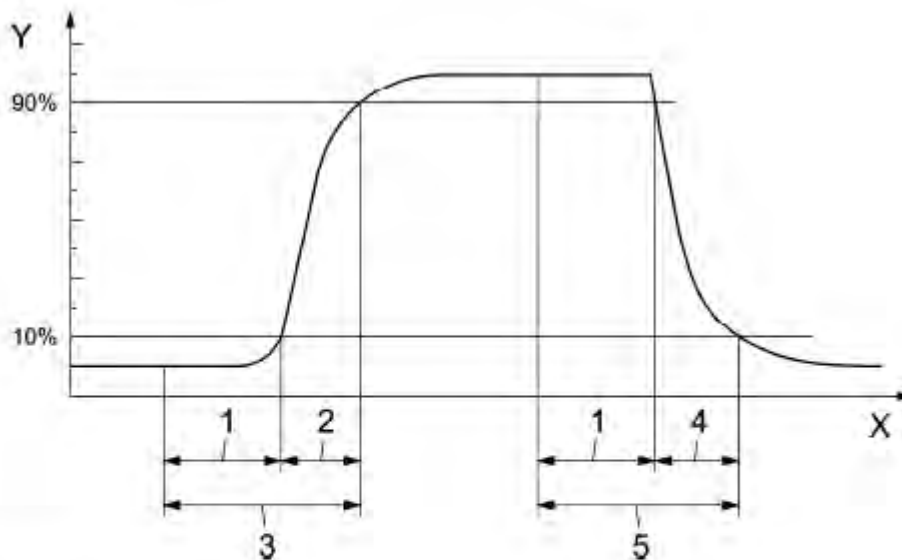
$$t_d = \bar{t}_r - \bar{t}_f$$

Where  $T_d$  is the difference between response time (rise) and response time (fall), in s;

$t_r$  is the response time (rise) (average of the four response times - rise), in s;

$t_f$  is the response time (fall) (average of the four response times - fall), in s.

$t_r$ ,  $t_f$  and  $t_d$  shall comply with the performance criteria indicated above.



**Key**

- Y analyser response
- X time
- 1 lag time
- 2 rise time
- 3 response time (rise)
- 4 fall time
- 5 response time (fall)

Figure 7: Diagram illustrating the response time

### 7.3 Testing

The test was performed in line with the requirements of EN 14625 mentioned before. An external data logger with the averaging time set to 1s was used to record data.

## 7.4 Evaluation

Table 4: Response time of the 49iQ measuring system for ozone

	requirement	device 1		device 2	
average rise $t_r$ [s]	$\leq 180$ s	59	✓	60.75	✓
average fall $t_f$ [s]	$\leq 180$ s	58.75	✓	61.5	✓
difference $t_d$ [s]	$\leq 10$ s	0.3	✓	-0.7	✓

For ozone system 1, the maximum  $t_r$  was 59, the maximum  $t_f$  was 58.75 and  $t_d$  0.3s.

For ozone system 2, the maximum  $t_r$  was 60.75, the maximum  $t_f$  was 61.5 and  $t_d$  -0.7 s.

## 7.5 Assessment

The values determined remained considerably below the maximum permissible response time of 180 s at all times. The maximum response time determined for system 1 was 60.75 s, for system 2, it was 61.5 s.

Criterion satisfied? yes



## 7.6 Detailed presentation of test results

Table 5: Individual results of the response time for ozone

80%		device 1					
measuring range	200.00	rise			fall		
		0.0 0.00	0.9 180.00	1.0 200.00	1.0 200.00	0.1 20.00	0.0 0.00
cycle 1	t = 0	13:32:00	13:33:01	13:34:00	13:39:00	13:39:59	13:41:00
	delta t		00:01:01			00:00:59	
	delta t [s]		61			59	
cycle 2	t = 0	13:46:00	13:46:59	13:48:00	13:53:00	13:54:00	13:55:00
	delta t		00:00:59			00:01:00	
	delta t [s]		59			60	
cycle 3	t = 0	14:00:00	14:00:57	14:02:00	14:07:00	14:07:58	14:09:00
	delta t		00:00:57			00:00:58	
	delta t [s]		57			58	
cycle 4	t = 0	14:14:00	14:14:59	14:16:00	14:21:00	14:21:58	14:23:00
	delta t		00:00:59			00:00:58	
	delta t [s]		59			58	

80%		device 2					
measuring range	200.00	rise			fall		
		0.0 0.00	0.9 180.00	1.0 200.00	1.0 200.00	0.1 20.00	0.0 0.00
cycle 1	t = 0	13:32:00	13:33:02	13:34:00	13:39:00	13:40:03	13:41:00
	delta t		00:01:02			00:01:03	
	delta t [s]		62			63	
cycle 2	t = 0	13:46:00	13:47:01	13:48:00	13:53:00	13:54:02	13:55:00
	delta t		00:01:01			00:01:02	
	delta t [s]		61			62	
cycle 3	t = 0	14:00:00	14:00:59	14:02:00	14:07:00	14:08:00	14:09:00
	delta t		00:00:59			00:01:00	
	delta t [s]		59			60	
cycle 4	t = 0	14:14:00	14:15:01	14:16:00	14:21:00	14:22:01	14:23:00
	delta t		00:01:01			00:01:01	
	delta t [s]		61			61	

## 7.1 8.4.4 Short-term drift

*Short-term drift at zero shall not exceed 2.0 nmol/mol/12 h.*

*The short-term drift at reference level shall not exceed 6.0 nmol/mol/12 h.*

## 7.2 Testing

After the required stabilisation period, the analyser shall be adjusted at zero and span level (around 70% to 80% of the maximum of the certification range). Wait the time equivalent to one independent reading and then record 20 individual measurements, first at zero and then at span concentration. From these 20 measurements, the average is calculated for zero and span level.

The analyser shall be kept running under the laboratory conditions. After a period of 12 h, zero and span gas is fed to the analyser. Wait the time equivalent to one independent reading and then record 20 individual measurements, first at zero and then at span concentration. The averages for zero and span level shall be calculated.

The short-term drift at zero and span level shall be calculated as follows:

$$D_{s,z} = (C_{z,2} - C_{z,1})$$

Where:

$D_{s,z}$  is the 12-hour drift at zero;

$C_{z,1}$  is the average concentration of the measurements at zero at the beginning of the drift period;

$C_{z,2}$  is the average concentration of the measurements at zero at the end of the drift period.

$D_{s,z}$  shall comply with the performance criterion indicated above.

$$D_{s,s} = (C_{s,2} - C_{s,1}) - D_{s,z}$$

Where:

$D_{s,s}$  is the 12-hour drift at span;

$C_{s,1}$  is the average concentration of the measurements at span level at the beginning of the drift period;

$C_{s,2}$  is the average concentration of the measurements at span level at the end of the drift period.

$D_{s,s}$  shall comply with the performance criterion indicated above.

### 7.3 Testing

The test was performed in line with the requirements of EN 14625 mentioned before. Pursuant to EN 14625, the test shall be performed at a concentration level of 70% to 80% of the certification range for ozone.

### 7.4 Evaluation

Table 6 indicates the measured value determined for the short-term drift.

*Table 6: Results for the short-term drift*

	requirements	device 1		device 2	
average at zero at the beginning [nmol/mol]	-	0.88		0.76	
average at zero at the end [nmol/mol]	-	0.77		0.46	
average at span at the beginning [nmol/mol]	-	184.28		184.16	
average at span at the end [nmol/mol]	-	183.55		183.61	
12-hour drift at zero $D_{s,z}$ [nmol/mol]	$\leq 2,0$	-0.11	✓	-0.30	✓
12-hour drift at span $D_{s,s}$ [nmol/mol]	$\leq 6,0$	-0.62	✓	-0.25	✓

### 7.5 Assessment

For instrument 1 the value for the short-term drift at zero point was -0.11 nmol/mol/12 h, for instrument 2 it was -0.30 nmol/mol/12 h.

Short-term drift at reference point was -0.62 nmol/mol/12 h for instrument 1 and -0.25 nmol/mol/12 h for instrument 2.

Criterion satisfied? yes

### 7.6 Detailed presentation of test results

Table 7 and Table 8 present the individual test results.

**Table 7:** *Individual results for the short-term drift 1 Test gas application:*

at beginning		
zero level		
	device 1	device 2
time	[nmol/mol]	[nmol/mol]
09:33:00	0.5	0.2
09:34:00	0.5	0.3
09:35:00	0.6	0.6
09:36:00	0.6	0.6
09:37:00	0.6	0.6
09:38:00	0.5	0.6
09:39:00	0.6	0.8
09:40:00	0.8	0.5
09:41:00	1.1	0.8
09:42:00	0.9	0.8
09:43:00	0.9	0.9
09:44:00	0.9	0.9
09:45:00	1.1	0.9
09:46:00	1.1	1.1
09:47:00	1.1	0.9
09:48:00	1.3	0.8
09:49:00	1.1	0.9
09:50:00	1.1	0.9
09:51:00	1.1	0.9
09:52:00	1.1	0.9
<b>average</b>	<b>0.9</b>	<b>0.8</b>

at beginning		
span level		
	device 1	device 2
time	[nmol/mol]	[nmol/mol]
10:08:00	186.4	185.9
10:09:00	186.4	186.3
10:10:00	185.9	185.6
10:11:00	185.9	185.6
10:12:00	185.2	184.8
10:13:00	185.2	185.2
10:14:00	184.5	184.7
10:15:00	184.5	184.7
10:16:00	184.4	184.2
10:17:00	184.1	183.9
10:18:00	184.2	183.9
10:19:00	183.3	183.3
10:20:00	183.6	183.6
10:21:00	183.4	183.4
10:22:00	183.1	183.4
10:23:00	183.4	183.1
10:24:00	183.3	183.1
10:25:00	183.0	182.8
10:26:00	183.0	183.0
10:27:00	182.8	182.5
<b>average</b>	<b>184.3</b>	<b>184.2</b>

**Table 8:** Individual results for the short-term drift 2 Test gas application:

after 12h		
zero level		
	device 1	device 2
time	[nmol/mol]	[nmol/mol]
21:33:00	0.3	-0.3
21:34:00	0.2	-0.3
21:35:00	0.5	0.2
21:36:00	0.6	0.3
21:37:00	0.6	0.3
21:38:00	0.6	0.3
21:39:00	0.6	0.2
21:40:00	0.6	0.5
21:41:00	0.8	0.5
21:42:00	0.8	0.5
21:43:00	0.8	0.5
21:44:00	0.9	0.5
21:45:00	0.9	0.5
21:46:00	0.9	0.8
21:47:00	0.9	0.5
21:48:00	1.3	0.9
21:49:00	0.9	0.8
21:50:00	0.9	1.1
21:51:00	0.9	1.1
21:52:00	1.1	0.6
<b>average</b>	<b>0.8</b>	<b>0.5</b>

after 12h		
span level		
	device 1	device 2
time	[nmol/mol]	[nmol/mol]
22:08:00	184.8	185.2
22:09:00	184.4	184.4
22:10:00	184.5	184.4
22:11:00	184.4	184.4
22:12:00	183.9	184.4
22:13:00	184.1	184.4
22:14:00	184.1	184.1
22:15:00	184.1	183.8
22:16:00	183.4	183.4
22:17:00	183.8	183.6
22:18:00	183.4	183.4
22:19:00	183.0	183.3
22:20:00	183.4	183.3
22:21:00	183.3	183.3
22:22:00	182.2	182.7
22:23:00	182.0	182.0
22:24:00	183.0	182.8
22:25:00	182.8	183.0
22:26:00	183.1	183.1
22:27:00	183.3	183.4
<b>average</b>	<b>183.5</b>	<b>183.6</b>

## 7.1 8.4.5 Repeatability standard deviation

*The performance criteria are as follows: Repeatability standard deviation at zero shall not exceed 1.0 nmol/mol. At a sample gas concentration at the reference point it shall not exceed 3 nmol/mol.*

## 7.2 Test procedure

After waiting the time equivalent of one independent reading, 20 individual measurements both at zero concentration and at a test concentration ( $c_t$ ), which is similar to that of the 1h alert threshold shall be performed.

From these measurements, the repeatability standard deviation ( $s_r$ ) at zero concentration and at concentration  $c_t$  shall be calculated according to:

$$s_r = \sqrt{\frac{\sum (x_i - \bar{x})^2}{n-1}}$$

Where:

- $s_r$  the repeatability standard deviation;
- $x_i$  the  $i$ th measurement;
- $\bar{x}$  is the average of the 20 measurements;
- $n$  is the number of measurements.

The repeatability standard deviation shall be calculated separately for both series of measurements (zero gas and concentration  $c_t$ ).

$s_r$  shall comply with the performance criterion indicated above, both at zero and at the test gas concentration  $c_t$  (1h alert threshold).

The detection limit, lower detection limit of the measuring system is calculated from the repeatability standard deviation and the slope of the calibration function determined in accordance with Chapter 8.4.6 according to the following equation:

$$l_{\text{det}} = 3,3 \cdot \frac{s_{r,z}}{B}$$

Where:

- $l_{\text{det}}$  is the detection limit, lower detection limit of the measuring system, in nmol/mol;
- $s_{r,z}$  is the repeatability standard deviation at zero, in nmol/mol;
- $B$  is the slope of the calibration function according to Annex A based on the data from 8.4.6.

### 7.3 Testing

The test was performed in line with the requirements of EN 14625 mentioned before. In compliance with the standard, the test has to be performed with the component ozone. Pursuant to EN 14625, the test shall be performed at a concentration level of 120 nmol/mol ozone.

### 7.4 Evaluation

Table 9 presents the results for the repeatability standard deviation.

*Table 9: Repeatability standard deviation at zero and reference point*

	requirement	device 1		device 2	
repeatability standard deviation $s_{r,z}$ at zero [nmol/mol]	$\leq 1,0$	0.19	✓	0.20	✓
repeatability standard deviation $s_{r,ct}$ at $c_t$ [nmol/mol]	$\leq 3,0$	0.34	✓	0.39	✓
detection limit [nmol/mol]		0.65		0.66	

### 7.5 Assessment

For instrument 1 the value for the repeatability standard deviation at zero point was 0.19 nmol/mol, for instrument 2 it was 0.20 nmol/mol. Repeatability standard deviation at reference point was 0.34 nmol/mol for instrument 1 and 0.39 nmol/mol for instrument 2.

Criterion satisfied? yes

### 7.6 Detailed presentation of test results

Table 10 lists the results of individual measurements.

**Table 10:** *Individual test results obtained for the repeatability standard deviation*

zero level		
	device 1	device 2
time	[nmol/mol]	[nmol/mol]
09:24:00	0.8	0.3
09:25:00	0.9	0.3
09:26:00	0.9	0.5
09:27:00	1.1	0.3
09:28:00	0.9	0.8
09:29:00	1.1	0.8
09:30:00	1.3	0.6
09:31:00	1.3	0.5
09:32:00	1.4	0.5
09:33:00	1.1	0.3
09:34:00	1.1	0.5
09:35:00	1.3	0.8
09:36:00	1.4	0.6
09:37:00	1.4	0.5
09:38:00	1.3	0.8
09:39:00	1.3	0.8
09:40:00	1.6	0.9
09:41:00	1.1	0.6
09:42:00	1.3	0.8
09:43:00	1.3	0.6
average	1.2	0.6

c <sub>t</sub> level		
	device 1	device 2
time	[nmol/mol]	[nmol/mol]
10:11:00	119.2	118.9
10:12:00	119.4	119.2
10:13:00	119.7	119.2
10:14:00	119.4	119.2
10:15:00	119.5	119.2
10:16:00	119.4	119.1
10:17:00	119.1	118.8
10:18:00	119.1	118.8
10:19:00	118.8	118.4
10:20:00	119.4	118.8
10:21:00	118.9	118.6
10:22:00	118.9	118.4
10:23:00	118.9	118.4
10:24:00	118.6	118.0
10:25:00	118.6	118.8
10:26:00	118.9	118.4
10:27:00	118.9	118.6
10:28:00	118.8	118.3
10:29:00	118.6	118.0
10:30:00	118.6	118.3
average	119.0	118.7



## 7.1 8.4.6 Lack of fit of linearity of the calibration function

*The deviation from the linearity of the calibration function at zero shall not exceed 5 nmol/mol. At concentrations above zero, it shall not exceed 4% of the measured value.*

### 7.2 Test procedure

The lack of fit of linearity of the calibration function of the analyser shall be tested over the range of 0% to 95% of the maximum of the certification range of NO, using at least six concentrations (including the zero point). The analyser shall be adjusted at a concentration of about 90% of the maximum of the certification range. At each concentration (including zero) at least five individual measurements shall be performed.

The concentrations shall be applied in the following sequence: 80%, 40%, 0%, 60%, 20% and 95%. After each change in concentration, at least four response times shall be taken into account before the next measurement is performed.

The regression function and the deviations are calculated in accordance with Annex A of standard EN 14625. The deviations from the linear regression function shall comply with the performance criterion specified above.

Establishment of the regression line:

A linear regression function in the form of  $Y_i = A + B * X_i$  is made through calculation of the following formula:

$$Y_i = a + B(X_i - X_z)$$

For the regression calculation, all measuring points (including zero) are taken into account. The total number of measuring points is equal to the number of concentration levels (at least six including zero) times the number of repetitions (at least five) at a particular concentration level.

The coefficient a is obtained from:

$$a = \sum Y_i / n$$

Where:

- a is the average value of the Y-values;
- $Y_i$  is the individual Y-value;
- N is the number of measuring points.

The coefficient B is obtained from:

$$B = \left( \sum Y_i (X_i - X_z) \right) / \sum (X_i - X_z)^2$$

Where:

- $X_z$  is the average of the x-values  $\left( = \sum (X_i / n) \right)$
- $X_i$  is the individual x-value.

is the individual x-value. The function  $Y_i = a + B (X_i - X_z)$  is converted to  $Y_i = A + B * X_i$  through the calculation of A:

$$A = a - B * X_z$$

The residuals of the averages of each calibration point (including the zero point) are calculated as follows.

The average of each calibration point (including the zero point) at one and the same concentration  $c$  is calculated according to:

$$(Y_a)_c = \sum (Y_i)_c / m$$

Where:

$(Y_a)_c$  is the average y-value at concentration level  $c$ ;

$(Y_i)_c$  is the individual y-value at concentration level  $c$ ;

$M$  is the number of repetitions at one and the same concentration level  $c$ ;

The residual of each average ( $r_c$ ) at each concentration level is calculated according to:

$$r_c = (Y_a)_c - (A + B \times c)$$

Each residual to a value relative to its own concentration level  $c$  is expressed in % as:

$$r_{c,rel} = \frac{r_c}{c} \times 100\%$$

### 7.3 Testing

The test was performed in line with the requirements of EN 14625 mentioned before.

### 7.4 Evaluation

The following linear regressions were established:

Figure 8 and Figure 9 provide a graphic summary of the group averages for ozone.

Table 11: Deviation from the analytical function for ozone

	requirements	device 1		device 2	
largest value of the relative residuals $r_{\max}$ [%]	$\leq 4,0$	1.88	✓	1.48	✓
residual at zero $r_z$ [nmol/mol]	$\leq 5,0$	1.28	✓	0.47	✓

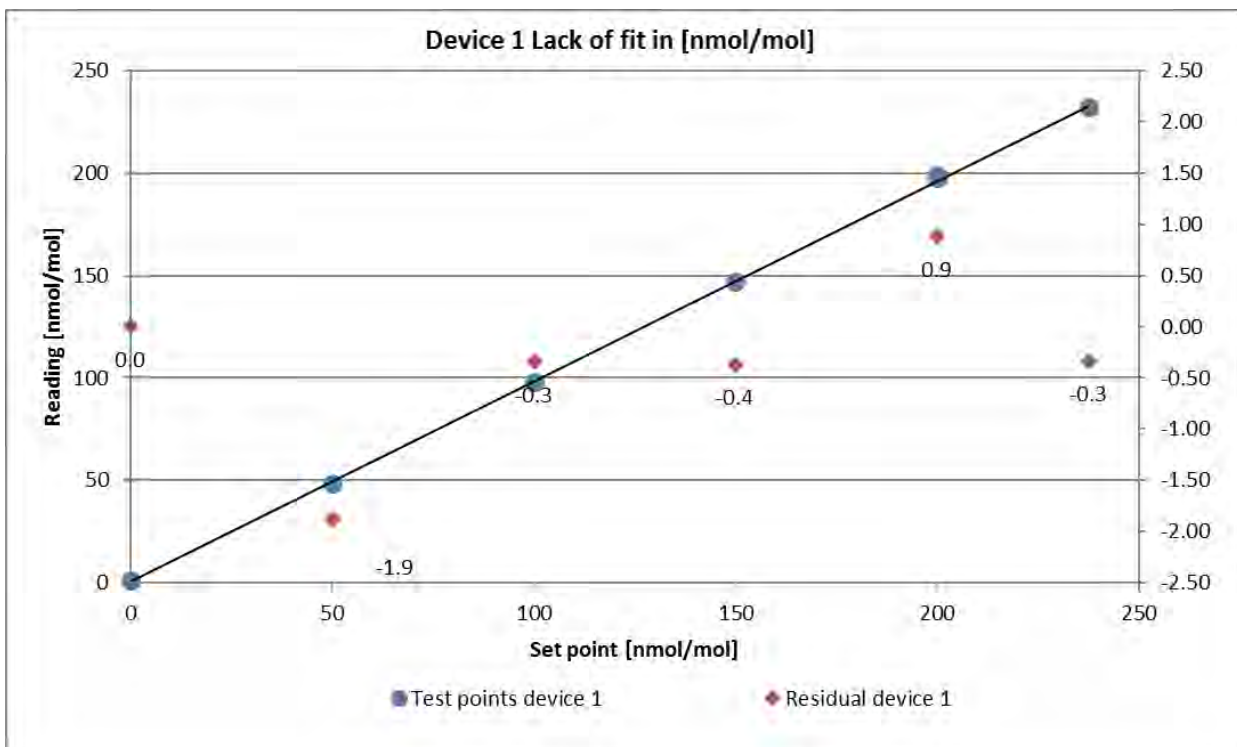


Figure 8: Analytical function obtained from the group averages for system 1

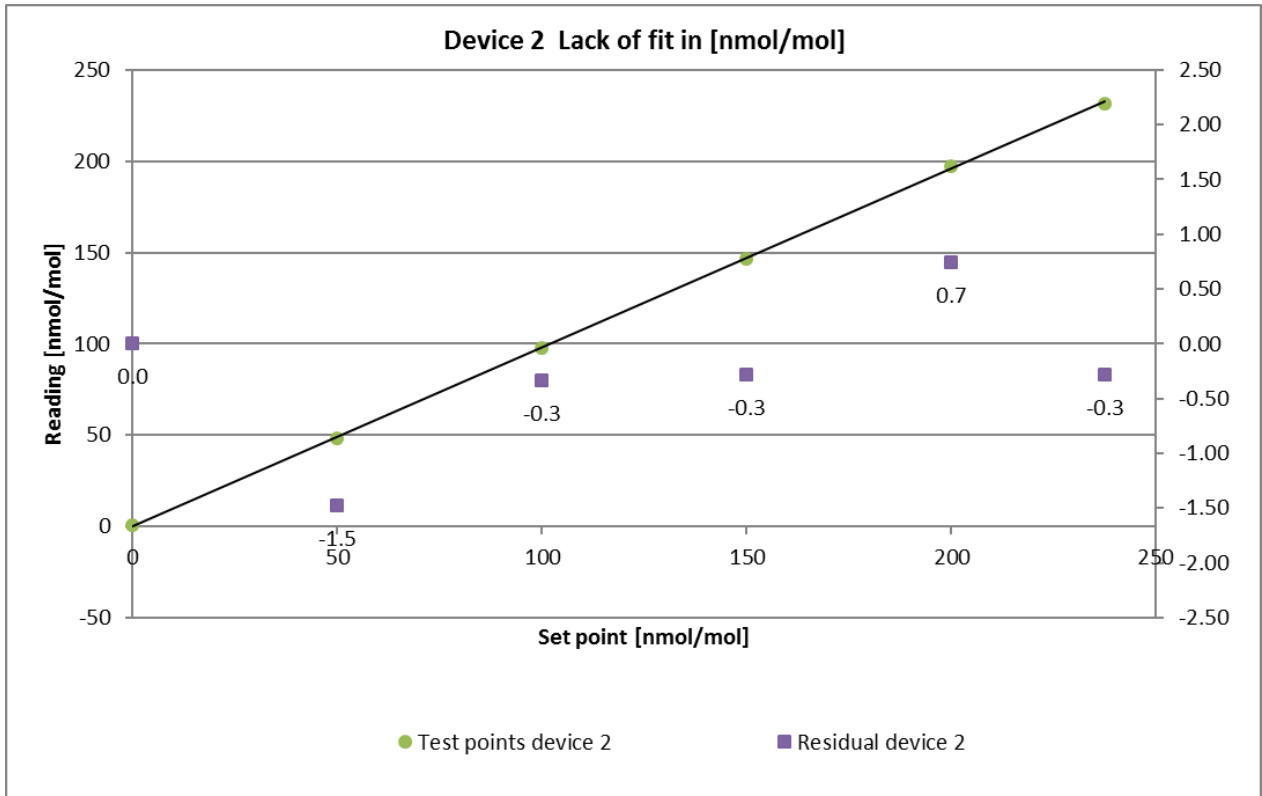


Figure 9: Analytical function obtained from the group averages for system 2

## 7.5 Assessment

The deviation from the linear regression line for instrument 1 is 1.88 nmol/mol at zero point and no more than 1.28% of the target value for concentrations above zero. The deviation from the linear regression line for instrument 2 is 1.48 nmol/mol at zero point and no more than 0.47% of the target value for concentrations above zero.

The residuals from the ideal regression line do not exceed the limit values required by standard EN 14625.

Criterion satisfied? yes

## 7.6 Detailed presentation of test results

Table 12 presents the individual test results.

**Table 12:** Individual results of the lack-of-fit test

		device 1 [nmol/mol]		device 2 [nmol/mol]	
time	level [%]	actual value $y_i$	set value $x_i$	actual value $y_i$	set value $x_i$
12:12:00	80	198.75	200.00	197.66	200.00
12:13:00	80	198.13	200.00	197.34	200.00
12:14:00	80	197.97	200.00	197.19	200.00
12:15:00	80	197.66	200.00	197.03	200.00
12:16:00	80	197.66	200.00	197.03	200.00
average		198.03		197.25	
$r_{c,rel}$		0.88		0.74	
12:26:00	40	98.28	100.00	97.97	100.00
12:27:00	40	98.13	100.00	97.50	100.00
12:28:00	40	98.13	100.00	97.34	100.00
12:29:00	40	97.66	100.00	97.50	100.00
12:30:00	40	97.81	100.00	96.88	100.00
average		98.00		97.44	
$r_{c,rel}$		-0.34		-0.33	
12:40:00	0	1.25	0.00	0.16	0.00
12:41:00	0	1.41	0.00	0.63	0.00
12:42:00	0	1.25	0.00	0.47	0.00
12:43:00	0	1.25	0.00	0.47	0.00
12:44:00	0	1.25	0.00	0.63	0.00
average		1.28		0.47	
$r_z$					
12:54:00	60	146.09	150.00	145.94	150.00
12:55:00	60	146.56	150.00	146.09	150.00
12:56:00	60	147.03	150.00	146.72	150.00
12:57:00	60	146.88	150.00	146.56	150.00
12:58:00	60	147.19	150.00	146.41	150.00
average		146.75		146.34	
$r_{c,rel}$		-0.37		-0.29	
13:08:00	20	49.06	50.00	48.75	50.00
13:09:00	20	48.44	50.00	47.97	50.00
13:10:00	20	48.28	50.00	47.97	50.00
13:11:00	20	48.13	50.00	47.50	50.00
13:12:00	20	48.28	50.00	47.97	50.00
average		48.44		48.03	
$r_{c,rel}$		-1.88		-1.48	
13:24:00	95	233.91	237.50	233.28	237.50
13:25:00	95	232.50	237.50	231.88	237.50
13:26:00	95	231.72	237.50	231.41	237.50
13:27:00	95	231.25	237.50	231.25	237.50
13:28:00	95	231.56	237.50	231.41	237.50
average		232.19		231.84	
$r_{c,rel}$		-0.34		-0.29	

## 7.1 8.4.7 Sensitivity coefficient to sample gas pressure

*The sensitivity coefficient of the sample gas pressure shall be  $\leq 2.0$  nmol/mol/kPa (corresponds to  $5.32 \mu\text{g}/\text{m}^3/\text{kPa}$ ).*

## 7.2 Test procedures

Measurements are taken at a concentration of about 70% to 80% of the maximum of the certification range of NO at an absolute pressure of about  $(80 \pm 0,2)$  kPa and at an absolute pressure of about  $(110 \pm 0,2)$  kPa. At each pressure after waiting the time equivalent to one independent reading, three individual measurements are recorded. From these measurements, the averages at each pressure are calculated.

Measurements at different pressures shall be separated by at least four response times.

The sensitivity coefficient to sample gas pressure is calculated as follows.

$$b_{sp} = \left| \frac{(C_{P2} - C_{P1})}{(P_2 - P_1)} \right|$$

Where:

$b_{sp}$  is the sample gas pressure sensitivity coefficient;

$C_{P1}$  is the average concentration of the measurements at sampling gas pressure  $P_1$ ;

$C_{P2}$  is the average concentration of the measurements at sampling gas pressure  $P_2$ ;

$P_1$  is the minimum sampling gas pressure  $P_1$ ;

$P_2$  is the maximum sampling gas pressure  $P_2$ .

$b_{sp}$  shall comply with the performance criterion indicated above.

## 7.3 Testing

The test was performed in line with the requirements of EN 14625 mentioned before.

Negative pressure was produced by reducing the test gas volume fed by means of blocking the sample gas line. For the positive pressure test, the AMS was connected to a sample gas source. The test gas volume generated was set at a higher rate than the volume sucked in by the analyser. The excess supply was diverted via a tee. The positive pressure was produced by blocking the bypass line. The test gas pressure was determined with the help of a pressure sensor located in the sample gas path.

Individual measurements were performed at concentrations around 70% to 80% of the maximum certification range and sample gas pressures of 80 kPa and 110 kPa.

## 7.4 Evaluation

The following sensitivity coefficients to sample gas pressure were determined:

*Table 13: Sensitivity coefficient of sample gas pressure*

	requirement	device 1		device 2	
sensitivity coeff. sample gas pressure $b_{gp}$ [nmol/mol/kPa]	$\leq 2,0$	0.20	✓	0.14	✓

## 7.5 Assessment

For instrument 1, the sensitivity coefficient to sample gas pressure is 0.20 nmol/mol/kPa.

For instrument 2, the sensitivity coefficient to sample gas pressure is 0.14 nmol/mol/kPa.

Criterion satisfied? yes

## 7.6 Detailed presentation of test results

*Table 14: Individual results of the sensitivity to changes in sample gas pressure*

time	pressure [kPa]	concentration	device 1	device 2
			[nmol/mol]	[nmol/mol]
11:02:00	80	187.50	187.97	183.91
11:03:00	80	187.50	189.06	183.44
11:04:00	80	187.50	188.59	184.38
average $C_{P1}$			188.54	183.91
11:16:00	110	187.50	183.13	180.00
11:17:00	110	187.50	182.66	180.16
11:18:00	110	187.50	181.41	179.38
average $C_{P2}$			182.40	179.84

### 8.4.8 Sensitivity coefficient to sample gas temperature

*The sensitivity coefficient to sample gas temperature shall be  $\leq 1.0 \mu\text{mol/mol/K}$ .*

#### 7.2 Test procedures

Measurements shall be performed at sample gas temperatures of  $T_{G,1} = 0 \text{ °C}$  and  $T_{G,2} = 30 \text{ °C}$ . The sensitivity coefficient to sample gas temperature is determined at a concentration of around 70% to 80% of the maximum certification range. Wait the time equivalent to one independent measurement and record three individual measurements at each temperature.

The sample gas temperature, measured at the inlet of the analyser, shall be held constant for at least 30 minutes.

The sensitivity coefficient to sample gas temperature is calculated as follows:

$$b_{gt} = \frac{(C_{GT,2} - C_{GT,1})}{(T_{G,2} - T_{G,1})}$$

Where:

- $b_{gt}$  is the sample gas temperature sensitivity coefficient;
- $C_{GT,1}$  is the average concentration of the measurements at sample gas temperature  $T_{G,1}$ ;
- $C_{GT,2}$  is the average concentration of the measurements at sample gas temperature  $T_{G,2}$ ;
- $T_{G,1}$  is the sample gas temperature  $T_{G,1}$ ;
- $T_{G,2}$  is the sample gas temperature  $T_{G,2}$ ;
- $b_{gt}$  shall comply with the performance criterion indicated above.

#### 7.3 Testing

The test was performed in line with the requirements of EN 14625 mentioned before.

For the purpose of this test, the test gas mixture was led through a 40m tube-bundle which was situated in a climatic chamber. The measuring systems were installed directly upstream of the climatic chamber. The end of the tube-bundle was led out of the climatic chamber and connected to the measuring systems. The feed line outside of the climatic chamber was isolated; a thermometer was used to monitor the temperature of the test gas directly upstream of the measuring system. The temperature of the climatic chamber was adjusted so that the gas temperature directly upstream of the analysers was exactly  $0 \text{ °C}$ . For the purpose of testing a gas temperature of  $30 \text{ °C}$ , gas was led through a heated line instead of the tube bundle in the climatic chamber.



## 7.4 Evaluation

Table 15: Sensitivity coefficient to sample gas temperature

	requirement	device 1		device 2	
sensitivity coeff. sample gas temperature $b_{gt}$ [nmol/mol/K]	$\leq 1,0$	0.09	✓	0.05	✓

## 7.5 Assessment

For instrument 1, the sensitivity coefficient to sample gas temperature is 0.09 nmol/mol/K.

For instrument 2, the sensitivity coefficient to sample gas temperature is 0.05 nmol/mol/K.

Criterion satisfied? yes

## 7.6 Detailed presentation of test results

Table 16: Individual results for the determination of the sensitivity to sample gas temperature

time	temp [°C]	concentration	device 1	device 2
			[nmol/mol]	[nmol/mol]
10:18:00	0	187.50	193.28	192.81
10:19:00	0	187.50	193.44	193.28
10:20:00	0	187.50	192.97	192.66
average $C_{GT,1}$			193.23	192.92
12:26:00	30	187.50	190.78	191.72
12:27:00	30	187.50	190.94	190.94
12:28:00	30	187.50	190.31	191.41
average $C_{GT,2}$			190.68	191.35

## 7.1 8.4.9 Sensitivity coefficient to surrounding temperature

*The sensitivity coefficient to surrounding temperature shall be  $\leq 1.0 \mu\text{mol/mol/K}$ .*

### 7.2 Test procedures

The sensitivity of the analyser readings to the surrounding temperature shall be determined by performing measurements at the following temperatures within the specifications of the manufacturer:

- 1) at the minimum temperature  $T_{\min} = 0 \text{ }^\circ\text{C}$ ;
- 2) at the temperature  $T_1 = 20 \text{ }^\circ\text{C}$ ;
- 3) at the maximum temperature  $T_{\max} = 30 \text{ }^\circ\text{C}$ .

For these tests, a climate chamber is necessary.

The sensitivity coefficient to surrounding temperature is determined at a concentration of around 70% to 80% of the maximum certification range. At each temperature setting after waiting the time equivalent to one independent measurement, three individual measurements at zero and at span shall be recorded.

The sequence of test temperatures is as follows:

$T_1, T_{\min}, T_1$  and  $T_1, T_{\max}, T_1$

At the first temperature ( $T_1$ ), the analyser shall be adjusted at zero and at span level (70% to 80% of the maximum of the certification range). Then three individual measurements are recorded after waiting the time equivalent to one independent reading at  $T_1$ , at  $T_{\min}$  and again at  $T_1$ . This measurement procedure shall be repeated at the temperature sequence of  $T_1, T_{\max}$  and at  $T_1$ .

In order to exclude any possible drift due to factors other than temperature, the measurements at  $T_1$  are averaged, which is taken into account in the following formula for calculation of the sensitivity coefficient for temperature dependence:

$$b_{st} = \left| \frac{x_T - \frac{x_1 + x_2}{2}}{T_S - T_{S,0}} \right|$$

Where:

$b_{st}$  is the surrounding temperature sensitivity coefficient;

$x_T$  is the average of the measurements at  $T_{\min}$  or  $T_{\max}$ ;

$x_1$  is the first average of the measurements at  $T_1$ ;

$x_2$  is the second average of the measurements at  $T_1$ ;

$T_S$  is the surrounding temperature in the laboratory;

$T_{S,0}$  is the average of the surrounding temperatures at set point.

For reporting the surrounding temperature dependence the higher value is taken of the two calculations of the temperature dependence at  $T_{S,1}$  and  $T_{S,2}$ .

$b_{st}$  shall comply with the performance criterion indicated above.

### 7.3 Testing

The test was performed in line with the requirements of EN 14625 mentioned before.

### 7.4 Evaluation

The following sensitivity coefficients to surrounding temperature have been determined:

*Table 17: Sensitivity coefficients to surrounding temperature*

	requirements	device 1		device 2	
sensitivity coefficient at 0 °C for zero level [nmol/mol/K]	$\leq 1,0$	0.027	✓	0.005	✓
sensitivity coefficient at 30 °C for zero level [nmol/mol/K]	$\leq 1,0$	0.026	✓	0.078	✓
sensitivity coefficient at 0 °C for span level [nmol/mol/K]	$\leq 1,0$	0.090	✓	0.091	✓
sensitivity coefficient at 30 °C for span level [nmol/mol/K]	$\leq 1,0$	0.115	✓	0.000	✓

As is evident from Table 17, the sensitivity coefficient to the surrounding temperature at zero and at reference point meets the performance criteria.

## 7.5 Assessment

The sensitivity coefficient to the surrounding temperature  $b_{st}$  did not exceed the performance criterion specified at 1.0 nmol/mol/K. For the purpose of uncertainty calculation, the largest value  $b_{st}$  is used for both instruments. For instrument 1, this is 0.115 nmol/mol/K and for instrument 2 it is 0.091 nmol/mol/K.

Criterion satisfied? yes

## 7.6 Detailed presentation of test results

Table 18 presents the individual test results.

**Table 18:** Individual test results for the sensitivity coefficient to ambient temperature

date	zero level				span level			
	time	temp [°C]	device 1 [nmol/mol]	device 2 [nmol/mol]	time	temp [°C]	device 1 [nmol/mol]	device 2 [nmol/mol]
28.05.2018	07:15:00	20	0.3	0.5	07:30:00	20	191.3	192.7
28.05.2018	07:16:00	20	0.2	0.2	07:31:00	20	191.3	190.0
28.05.2018	07:17:00	20	0.0	0.8	07:32:00	20	191.6	190.8
average ( $X_{1(TS1)}$ )			0.2	0.5			191.4	191.1
28.05.2018	13:51:00	0	0.6	0.8	14:05:00	0	193.3	193.0
28.05.2018	13:52:00	0	0.2	1.4	14:06:00	0	192.3	192.0
28.05.2018	13:53:00	0	1.1	1.3	14:07:00	0	192.0	192.0
average ( $X_{TS1}$ )			0	1.1			192.6	192.3
29.05.2018	07:05:00	20	-0.5	1.3	07:20:00	20	191.1	190.6
29.05.2018	07:06:00	20	0.3	1.6	07:21:00	20	189.8	189.4
29.05.2018	07:07:00	20	0.2	2.0	07:22:00	20	189.5	189.7
average ( $X_{2(TS1)} = X_{1(TS2)}$ )			0.0	1.6			190.2	189.9
29.05.2018	13:55:00	30	0.3	1.4	14:10:00	30	191.6	189.8
29.05.2018	13:56:00	30	1.1	1.1	14:11:00	30	190.9	188.9
29.05.2018	13:57:00	30	1.1	1.4	14:12:00	30	190.3	189.1
average ( $X_{TS2}$ )			0.8	1.3			190.9	189.3
30.05.2018	07:20:00	20	1.1	2.0	07:35:00	20	190.2	188.8
30.05.2018	07:21:00	20	0.9	2.8	07:36:00	20	189.2	188.3
30.05.2018	07:22:00	20	1.4	2.8	07:37:00	20	188.9	188.9
average ( $X_{2(TS2)}$ )			1.1	2.6			189.4	188.6

## 7.1 8.4.10 Sensitivity coefficient to electrical voltage

*The sensitivity coefficient to electrical voltage shall not exceed 0.3 nmol/mol/V.*

### 7.2 Test procedures

The sensitivity coefficient of electrical voltage shall be determined at both ends of the voltage range specified by the manufacturer,  $V_1$  and  $V_2$ , at zero concentration and at a concentration around 70% to 80% of the maximum of the certification range of NO. After waiting the time equivalent to one independent measurement, three individual measurements at each voltage and concentration level shall be recorded.

The sensitivity coefficient to electrical voltage in accordance with EN 14625 is calculated as follows:

$$b_v = \frac{|(C_{V2} - C_{V1})|}{|V_2 - V_1|}$$

Where:

$b_v$  is the voltage sensitivity coefficient,

$C_{V1}$  is the average concentration reading of the measurements at voltage  $V_1$

$C_{V2}$  is the average concentration reading of the measurements at voltage  $V_2$

$V_1$  is the minimum voltage  $V_{\min}$

$V_2$  is the maximum voltage  $V_{\max}$

For reporting the dependence on voltage, the higher value of the result at zero and span level shall be taken.

$b_v$  shall comply with the performance criterion indicated above.

### 7.3 Testing

For the purpose of determining the sensitivity coefficient to electrical voltage, a transformer was looped into the measuring system's voltage supply. Test gases were applied to the zero and reference point at various voltages.

### 7.4 Evaluation

The following sensitivity coefficients to electrical voltage have been determined:

**Table 19: Sensitivity coefficient to electrical voltage**

	requirement	device 1		device 2	
sensitivity coeff. of voltage $b_v$ at zero level [nmol/mol/V]	$\leq 0,3$	0.00	✓	0.00	✓
sensitivity coeff. of voltage $b_v$ at span level [nmol/mol/V]	$\leq 0,3$	0.02	✓	0.01	✓

## 7.5 Assessment

At no test item did the sensitivity coefficient to electrical voltage  $b_v$  exceed the value of 0.3 nmol/mol/V specified in standard EN 14625. For the purpose of uncertainty calculation, the largest  $b_v$  is used for both instruments. For instrument 1, this is 0.02 nmol/mol/V and for instrument 2 it is 0.01 nmol/mol/V.

Criterion satisfied? yes

## 7.6 Detailed presentation of test results

**Table 20: Individual results of the sensitivity coefficient to electrical voltage**

time	voltage [V]	concentration	device 1	device 2
			[nmol/mol]	[nmol/mol]
11:45:00	207	0	0.94	0.47
11:46:00	207	0	1.09	0.31
11:47:00	207	0	1.09	0.31
average $C_{V1}$ at zero			1.04	0.36
11:55:00	253	0	1.09	0.47
11:56:00	253	0	0.78	0.47
11:57:00	253	0	0.94	0.16
average $C_{V2}$ at zero			0.94	0.36
12:06:00	207	175.00	176.41	174.22
12:07:00	207	175.00	177.19	174.38
12:08:00	207	175.00	177.34	175.00
average $C_{V1}$ at Span			176.98	174.53
12:16:00	253	175.00	176.72	174.38
12:17:00	253	175.00	175.94	173.75
12:18:00	253	175.00	176.09	174.06
average $C_{V2}$ at Span			176.25	174.06

## 7.1 8.4.11 Interferents

*Interferents at zero and concentration  $c_t$  (at the level of the 1h alert threshold = 120 nmol/mol for ozone). The deviation caused by the interferent toluene and m-xylene shall not exceed 5.0 nmol/mol; for toluene, and m-xylenes, it shall not exceed 10.0 nmol/mol for H<sub>2</sub>O.*

## 7.2 Test procedures

The analyser response to certain interferents shall be tested. The interferents can give a positive or negative response. The test was performed at a concentration of zero and at test gas concentration ( $c_t$ ), which is similar to the 1h alert threshold (120 nmol/mol).

The concentration of the mixtures of the test gases with the interferent shall have an expanded uncertainty of  $\leq 5\%$  and shall be traceable to nationally accepted standards. The interferents to be tested and their respective concentrations are given in Table 21. The influence of each interferent shall be determined separately. A correction on the concentration of the measurand shall be made for the dilution effect due to addition of an interferent (e.g. water vapour).

After adjustment of the analyser at zero and span level, the analyser shall be fed with a mixture of zero gas and the interferent to be investigated with the concentration as given in Table 21. With this mixture, one independent measurement of NO followed by two individual measurements of NO shall be carried out. This procedure shall be repeated with a mixture of the measurand at concentration  $c_t$  and the interferent to be investigated. The influence quantities at zero and concentration  $c_t$  are calculated from:

$$X_{\text{int},z} = x_z$$

$$X_{\text{int},ct} = x_{ct} - c_t$$

Where:

$X_{\text{int},z}$  is the influence quantity of the interferent at zero;

$x_z$  is the average of the measurements of NO at zero;

$X_{\text{int},ct}$  is the influence quantity of the interferent at concentration  $c_t$ ;

$x_{ct}$  is the average of the measurements of NO at concentration  $c_t$

$c_t$  is the applied concentration at the one-hour limit value.

The influence quantities of the interferents shall comply with the performance criteria indicated above, both at zero and at concentration  $c_t$ .

## 7.3 Testing

The test was performed in line with the requirements of EN 14625 mentioned before. Systems were set to concentrations zero and  $c_t$  (~ 120 nmol/mol). Zero and test gas with the various interfering components were then applied. The interferents listed in Table 21 were applied in the concentrations indicated.

**Table 21:** Interferents in accordance with EN 14625

Interferent	Value
H <sub>2</sub> O	19 mmol/mol
Toluol	0.5 µmol/mol
M-Xylene	0.5 µmol/mol

## 7.4 Evaluation

The following overview presents the influence quantities of each interfering substance. When determining the influence of moisture, the dilution effect which occurs inside the test gas generation system was also taken into account.

**Table 22:** Influence of the tested interferents ( $c_t = 120 \text{ nmol/mol}$ )

	requirements	device 1		device 2	
influence quantity interferent H <sub>2</sub> O at zero [nmol/mol/V]	≤ 10,0 nmol/mol	-2.03	✓	-0.89	✓
influence quantity interferent H <sub>2</sub> O at $c_t$ [nmol/mol/V]	≤ 10,0 nmol/mol	-1.67	✓	-0.47	✓
influence quantity interferent toluol at zero [nmol/mol/V]	≤ 5,0 nmol/mol	1.46	✓	2.24	✓
influence quantity interferent toluol at $c_t$ [nmol/mol/V]	≤ 5,0 nmol/mol	4.27	✓	4.05	✓
influence quantity interferent m-Xylol at zero [nmol/mol/V]	≤ 5,0 nmol/mol	2.30	✓	2.45	✓
influence quantity interferent m-Xylol at $c_t$ [nmol/mol/V]	≤ 5,0 nmol/mol	4.75	✓	4.63	✓

## 7.5 Assessment

At zero point the result for the interference were -2.03 nmol/mol (AMS 1) and -0.89 nmol/mol (AMS 2) for H<sub>2</sub>O, 1.46 nmol/mol (AMS 1) and 2.24 nmol/mol (AMS 2) for toluene and finally 2.30 nmol/mol (AMS 1) and 2.45 nmol/mol (AMS 2) for m-xylene.

At the limit value, the result for the interference were -1.67 nmol/mol (AMS 1) and -0.47 nmol/mol (AMS 2) for H<sub>2</sub>O, 4.27 nmol/mol (AMS 1) and 4.05 nmol/mol (AMS 2) for toluene and finally 4.75 nmol/mol (AMS 1) and 4.63 nmol/mol (AMS 2) for m-xylene.

Criterion satisfied? yes

## 7.6 Detailed presentation of test results

Table 23 presents the individual test results.



**Table 23:** Individual results for testing interferences

	without interferences			with interferences		
	time	device 1	device 2	time	device 1	device 2
zero gas + H <sub>2</sub> O (19 mmol/mol)	13:33:00	-0.94	0.31	0.57	-2.81	-0.31
	13:34:00	-0.78	0.16	0.57	-2.66	-0.63
	13:35:00	-0.63	0.47	0.57	-2.97	-0.78
	average x <sub>z</sub>	-0.78	0.31	average x <sub>z</sub>	-2.81	-0.57
test gas c <sub>t</sub> + H <sub>2</sub> O (19 mmol/mol)	13:53:00	120.00	118.59	0.59	118.13	118.28
	13:54:00	120.00	118.75	0.59	118.59	118.59
	13:55:00	120.31	119.06	0.59	118.59	118.13
	average x <sub>ct</sub>	120.10	118.80	average x <sub>ct</sub>	118.44	118.33
zero gas + Toluol (0,5 µmol/mol)	10:46:00	0.00	0.94	0.45	1.88	3.44
	10:47:00	0.47	1.25	0.45	2.19	3.28
	10:48:00	1.41	1.25	0.46	2.19	3.44
	average x <sub>z</sub>	0.63	1.15	average x <sub>z</sub>	2.09	3.39
test gas c <sub>t</sub> + Toluol (0,5 µmol/mol)	12:19:00	122.81	121.88	0.52	126.41	125.00
	12:20:00	122.34	121.72	0.52	126.72	126.06
	12:21:00	122.66	121.72	0.52	127.50	126.41
	average x <sub>ct</sub>	122.60	121.77	average x <sub>ct</sub>	126.88	125.82
zero gas + m-Xylol (0,5 µmol/mol)	12:35:00	-0.16	1.25	0.53	2.19	3.91
	12:36:00	-0.31	1.25	0.53	2.19	3.59
	12:37:00	-0.16	1.09	0.53	1.88	3.44
	average x <sub>z</sub>	-0.21	1.20	average x <sub>z</sub>	2.09	3.65
test gas c <sub>t</sub> + m-Xylol (0,5 µmol/mol)	13:07:00	122.34	121.41	0.55	127.03	126.25
	13:08:00	122.34	121.56	0.55	127.06	125.94
	13:09:00	122.81	121.88	0.55	127.66	126.56
	average x <sub>ct</sub>	122.50	121.62	average x <sub>ct</sub>	127.25	126.25

## 7.1 8.4.12 Averaging test

*The averaging effect shall not exceed 7% of the measured value.*

### 7.2 Test conditions

The averaging test gives a measure of the uncertainty in the averaged values caused by short-term concentration variations in the sampled air shorter than the time scale of the measurement process in the analyser. In general, the output of an analyser is a result of the determination of a reference concentration (normally zero) and the actual concentration which takes a certain time.

For the determination of the uncertainty due to averaging, the following concentrations are applied to the analyser and readings are taken at each concentration: a constant ozone concentration between 0 and concentration  $c_t$ .

The time period ( $t_c$ ) of the constant ozone concentration shall be at least equal to a period necessary to obtain four independent readings. four independent readings (which is equal to at least sixteen response times). The time period ( $t_v$ ) of the varying ozone concentration shall be at least equal to a period to obtain four independent readings. The time period ( $t_{o_3}$ ) for the ozone concentration shall be 45 s followed by a period ( $t_{zero}$ ) of 45 s of zero concentration. Further:

$c_t$  is the test concentration;

$t_v$  is a time period including a whole number of  $t_{o_3}$  and  $t_{zero}$  pairs, and contains a minimum of three such pairs, in s.

The change from  $t_{o_3}$  to  $t_{zero}$  shall be within 0.5 s. The change from  $t_c$  to  $t_v$  shall be within one response time of the analyser under test.

The averaging effect ( $E_{av}$ ) is calculated according to:

$$E_{av} = \frac{C_{const}^{av} - 2C_{var}^{av}}{C_{const}^{av}} * 100$$

Where:

$E_{av}$  is the averaging effect (%);

$C_{const}^{av}$  is the average of the at least four independent measurements during the variable concentration period;

$C_{var}^{av}$  is the average of the at least four independent measurements during the variable concentration period;

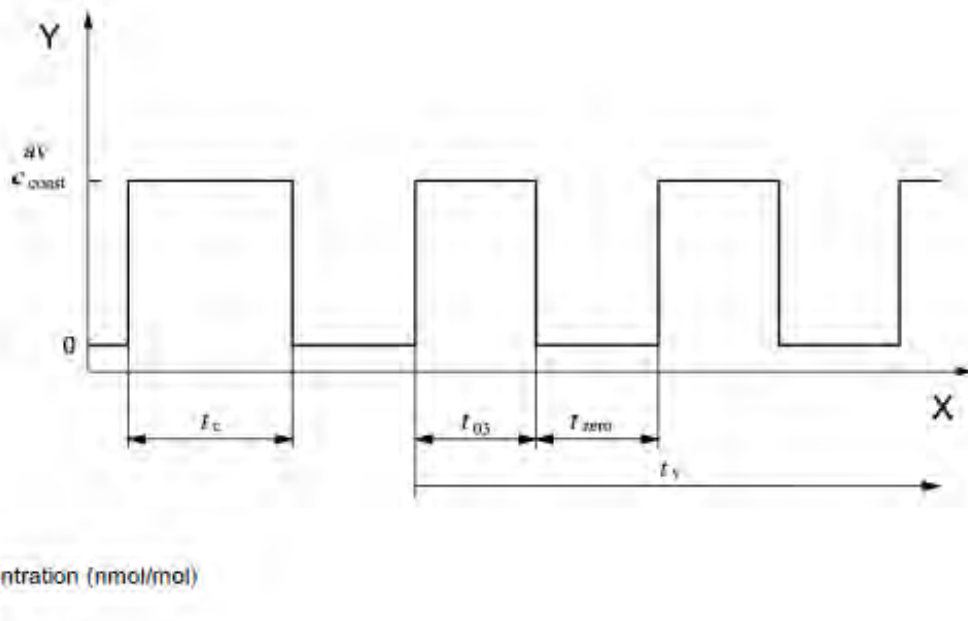


Figure 10: Test of the averaging effect ( $t_{O_3} = t_{zero} = 45$  s.)

### 7.3 Testing

The averaging test was performed in compliance with the requirements specified in EN 14625. This test was performed using a step change between zero and concentration  $c_t$  (120 nmol/mol) since this AMS is a directly measuring ozone analyser. First, the average was calculated at a constant test gas concentration. Then, a three-way valve served to switch between zero and test gas every 45 s. During that period of alternating test gas application the average was calculated again.

### 7.4 Evaluation

The following averages were determined during the test:

Table 24: Results of the averaging test

	requirement	device 1		device 2	
averaging effect $E_{av}$ [%]	$\leq 7\%$	-5.4	✓	-6.4	✓

This results in the following averaging effects:

System 1 (12): -5.4 %

System 2 (14): -6.4 %

### 7.5 Assessment

The performance criterion specified by standard EN 14625 is fully satisfied.

Criterion satisfied? yes

### 7.6 Detailed presentation of test results

Table 25 presents the individual results of the averaging test:

*Table 25: Individual results of the averaging test*

		device 1	device 2
	time	[nmol/mol]	[nmol/mol]
average constant concentration $C_{av,c}$	11:51:00	120.0	120.0
	till		
	12:20:00		
average variable concentration $C_{av,c}$	12:13:00	63.6	63.9
	till		
	12:32:00		

		device 1	device 2
	time	[nmol/mol]	[nmol/mol]
average constant concentration $C_{av,c}$	12:35:00	118.8	118.7
	till		
	12:54:00		
average variable concentration $C_{av,c}$	12:56:00	61.8	63.0
	till		
	13:15:00		

		device 1	device 2
	time	[nmol/mol]	[nmol/mol]
average constant concentration $C_{av,c}$	13:20:00	119.1	119.2
	till		
	13:39:00		
average variable concentration $C_{av,c}$	13:41:00	63.2	63.5
	till		
	14:00:00		

## 7.1 8.4.13 Difference sample/calibration port

*The difference between sample and calibration port shall not exceed 1.0%.*

### 7.2 Test procedures

If the analyser has different ports for feeding sample gas and calibration gas, the difference in response of the analyser to feeding through the sample or calibration port shall be tested. The test shall be carried out by feeding the analyser with a test gas with a concentration of 70% to 80% of the maximum of the certification range of NO through the sample port. The test shall consist of one independent measurement followed by two individual measurements. After a period of at least four response times, the test shall be repeated using the calibration port. The difference shall be calculated according to:

$$\Delta x_{SC} = \frac{x_{sam} - x_{cal}}{c_t} \times 100$$

Where:

$\Delta x_{SC}$  is the difference sample/calibration port;

$x_{sam}$  is the average of the measured concentration using the sample port;

$x_{cal}$  is the average of the measured concentration using the calibration port;

$c_t$  is the concentration of the test gas;

$\Delta_{SC}$  shall comply with the performance criterion indicated above.

### 7.3 Testing

The test was performed in compliance with the requirements specified in EN 14625. During the test, the gas path was switched between sample gas and span gas inlet using a three-way valve.

### 7.4 Evaluation

During the test, the following differences between sample and calibration port were determined:

*Table 26: Results of determining the difference between sample/calibration inlet*

	requirement	device 1		device 2	
difference sample/calibration port $\Delta x_{cs}$ [%]	$\leq 1\%$	0.17	✓	0.08	✓

### 7.5 Assessment

The performance criterion specified by standard EN 14625 is fully satisfied.

Criterion satisfied? yes

## 7.6 Detailed presentation of test results

Table 27 presents the individual results.

*Table 27: Individual results for testing the difference between sample and calibration port*

		device 1	device 2
	time	[nmol/mol]	[nmol/mol]
calibration port	12:22:00	191.1	190.2
	12:23:00	190.9	189.2
	12:24:00	190.2	188.9
sample port	12:32:00	190.5	188.9
	12:33:00	190.3	189.4
	12:34:00	190.5	189.5

## **7.1      8.4.14   Residence time in the analyser**

*The residence time in the analyser shall be  $\leq 3.0$  s.*

## **7.2      Test procedures**

The residence time inside the analyser shall be calculated on the basis of the flow and the volumes of the tubing and other relevant components inside the analyser.

## **7.3      Testing**

The gas volume of the 49iQ measuring system is approximately 25.0 ml from the sample inlet to the measuring cell. The typical sample gas flow is at 1.5 l/min. This results in a residence time in the analyser of 1.0 s.

## **7.4      Evaluation**

Not applicable.

## **7.5      Assessment**

Residence time in the analyser was 1.0 s.

Criterion satisfied? yes

## **7.6      Detailed presentation of test results**

Not applicable.

## 7.1 8.5.4 Long-term drift

*The long-term drift at zero point shall not exceed  $\leq 5.0$  nmol/mol.  
Long-term drift at span level shall not exceed 5% of the certification range.*

## 7.2 Test procedures

After each bi-weekly zero and span check, the drift of the analysers under test shall be calculated at zero and at span following the procedures as given below. If the drift compared to the initial calibration exceeds one of the performance criteria for drift at zero or span level, the “period of unattended operation” equals the number of weeks until the observation of the infringement, minus two weeks. For further (uncertainty) calculations, the values for “long term drift” are the values for zero and span drift over the period of unattended operation.

At the beginning of the drift period, five individual measurements were performed at zero and span level following the calibration (after waiting the time equivalent to a single independent reading).

The long-term drift is calculated as follows:

$$D_{L,Z} = (C_{Z,1} - C_{Z,0})$$

Where:

$D_{L,Z}$  is the drift at zero;

$C_{Z,0}$  is the average concentration of the measurements at zero at the beginning of the drift period;

$C_{Z,1}$  is the average concentration of the measurements at zero at the end of the drift period;

$D_{L,Z}$  shall comply with the performance criterion indicated above.

$$D_{L,S} = \frac{(C_{S,1} - C_{S,0}) - D_{L,Z}}{C_{S,1}} \times 100$$

Where:

$D_{L,S}$  is the drift at span concentration  $c_i$ ;

$C_{S,0}$  is the average concentration of the measurements at span level at the beginning of the drift period;

$C_{S,1}$  is the average concentration of the measurements at span level at the end of the drift period;

$D_{L,S}$  shall comply with the performance criterion indicated above.



### 7.3 Testing

For the purpose of this test, test gas was applied every other week. Table 28 and Table 29 report the measured values for bi-weekly test gas applications.

### 7.4 Evaluation

Table 28: Results for the long-term drift at zero point

		requirement	Device 1		Device 2	
average start $C_{z,1}$ at zero [nmol/mol]	11.06.2018	$\leq 5,0$ nmol/mol	--	✓	--	✓
long term drift $D_{L,z}$ at zero [nmol/mol]	25.06.2018	$\leq 5,0$ nmol/mol	1.07	✓	1.15	✓
long term drift $D_{L,z}$ at zero [nmol/mol]	09.07.2018	$\leq 5,0$ nmol/mol	1.04	✓	1.24	✓
long term drift $D_{L,z}$ at zero [nmol/mol]	23.07.2018	$\leq 5,0$ nmol/mol	1.73	✓	1.65	✓
long term drift $D_{L,z}$ at zero [nmol/mol]	06.08.2018	$\leq 5,0$ nmol/mol	1.89	✓	1.30	✓
long term drift $D_{L,z}$ at zero [nmol/mol]	20.08.2018	$\leq 5,0$ nmol/mol	-0.30	✓	-0.92	✓
long term drift $D_{L,z}$ at zero [nmol/mol]	03.09.2018	$\leq 5,0$ nmol/mol	-0.27	✓	0.68	✓
long term drift $D_{L,z}$ at zero [nmol/mol]	17.09.2018	$\leq 5,0$ nmol/mol	0.14	✓	0.15	✓

Table 29: Results for the long-term drift at reference point

		requirement	Device 2 1		Device 2	
average start $C_{s,1}$ at span [nmol/mol]	11.06.2018	$\leq 5$ %	--	✓	--	✓
long term drift $D_{L,s}$ at span [nmol/mol]	25.06.2018	$\leq 5$ %	-0.91	✓	-0.24	✓
long term drift $D_{L,s}$ at span [nmol/mol]	09.07.2018	$\leq 5$ %	-0.84	✓	-0.78	✓
long term drift $D_{L,s}$ at span [nmol/mol]	23.07.2018	$\leq 5$ %	-2.70	✓	-1.70	✓
long term drift $D_{L,s}$ at span [nmol/mol]	06.08.2018	$\leq 5$ %	-1.84	✓	-1.26	✓
long term drift $D_{L,s}$ at span [nmol/mol]	20.08.2018	$\leq 5$ %	-0.14	✓	1.38	✓
long term drift $D_{L,s}$ at span [nmol/mol]	03.09.2018	$\leq 5$ %	0.20	✓	-0.31	✓
long term drift $D_{L,s}$ at span [nmol/mol]	17.09.2018	$\leq 5$ %	1.21	✓	1.81	✓

### 7.5 Assessment

Maximum long-term drift at zero point  $D_{i,z}$  was at 1.89 nmol/mol for instrument 1 and 1.65 nmol/mol for instrument 2. Maximum long-term drift at reference point  $D_{i,s}$  was at -2.70% for instrument 1 and 1.81% for instrument 2.

Criterion satisfied? yes

### 7.6 Detailed presentation of test results

Table 30 presents the individual values obtained for the determination of the long-term drift.

**Table 30: Individual results for differences**

Zero Concentration				C <sub>t</sub> -Concentration			
Date	Time	Device 1	Device 2	Date	Time	Device 1	Device 2
		[nmol/mol]	[nmol/mol]			[nmol/mol]	[nmol/mol]
11.06.2018	10:32:00	0.31	0.31	11.06.2018	10:58:00	182.50	181.41
	10:33:00	0.31	0.00		10:59:00	180.78	180.16
	10:34:00	0.31	0.00		11:00:00	180.94	178.91
	Mittel	0.31	0.10		Mittel	181.41	180.16
	10:36:00	0.31	0.00		11:02:00	180.94	180.47
	10:37:00	0.31	0.16		11:03:00	180.78	179.69
	10:38:00	0.63	0.63		11:04:00	181.09	180.16
	Mittel	0.42	0.26		Mittel	180.94	180.10
	10:40:00	-0.16	0.00		11:06:00	177.81	174.53
	10:41:00	-0.31	0.16		11:07:00	179.69	178.28
	10:42:00	0.47	0.00		11:08:00	180.94	179.22
	Mittel	0.00	0.05		Mittel	179.48	177.34
	10:44:00	-0.31	0.00		11:10:00	180.78	179.38
	10:45:00	-0.31	0.78		11:11:00	180.31	179.69
	10:46:00	0.31	0.16		11:12:00	181.09	180.00
	Mittel	-0.10	0.31		Mittel	180.73	179.69
	10:48:00	0.47	0.16		11:14:00	180.63	179.69
	10:49:00	0.31	0.16		11:15:00	180.78	179.84
	10:50:00	0.00	0.00		11:16:00	180.78	179.84
			0.26		0.10		
<b>Average field start c<sub>z,0</sub></b>		<b>0.18</b>	<b>0.17</b>	<b>Average field start c<sub>s,0</sub></b>		<b>180.66</b>	<b>179.42</b>
25.06.2018	08:52:00	0.78	1.25	25.06.2018	09:05:00	180.16	180.47
	08:53:00	1.25	1.09		09:06:00	180.47	179.22
	08:54:00	1.25	1.56		09:07:00	180.00	180.63
	08:55:00	1.56	1.09		09:08:00	180.00	180.16
	08:56:00	1.41	1.56		09:09:00	179.84	180.16
	aver. cz,1	<b>1.25</b>	<b>1.31</b>		Mittel cs,1	<b>180.09</b>	<b>180.13</b>
09.07.2018	12:53:00	0.47	0.63	09.07.2018	13:06:00	180.47	179.69
	12:54:00	0.94	1.41		13:07:00	180.16	179.06
	12:55:00	1.25	1.41		13:08:00	180.16	179.38
	12:56:00	1.72	1.41		13:09:00	180.16	179.22
	12:57:00	1.72	2.19		13:10:00	180.00	178.91
	aver. cz,1	<b>1.22</b>	<b>1.41</b>		aver. cs,1	<b>180.19</b>	<b>179.25</b>
23.07.2018	08:56:00	1.72	1.56	23.07.2018	09:09:00	178.75	178.59
	08:57:00	1.56	1.72		09:10:00	178.91	178.75
	08:58:00	1.88	1.56		09:11:00	177.34	178.91
	08:59:00	2.34	1.88		09:12:00	176.56	177.34
	09:00:00	2.03	2.34		09:13:00	176.41	176.56
	aver. cz,1	<b>1.91</b>	<b>1.81</b>		aver. cs,1	<b>177.59</b>	<b>178.03</b>
06.08.2018	08:36:00	1.41	0.94	06.08.2018	08:51:00	180.00	178.59
	08:37:00	2.03	1.56		08:52:00	179.22	178.75
	08:38:00	2.19	1.56		08:53:00	178.44	177.34
	08:39:00	2.19	1.56		08:54:00	179.53	179.06
	08:40:00	2.50	1.72		08:55:00	179.06	178.59
	aver. cz,1	<b>2.06</b>	<b>1.47</b>		aver. cs,1	<b>179.25</b>	<b>178.47</b>
20.08.2018	13:09:00	-1.88	-2.50	20.08.2018	13:24:00	178.13	183.44
	13:10:00	-0.63	-1.72		13:25:00	181.41	181.88
	13:11:00	0.16	-0.63		13:26:00	180.16	180.31
	13:12:00	0.78	0.16		13:27:00	179.22	178.75
	13:13:00	0.94	0.94		13:28:00	181.56	180.63
	aver. cz,1	<b>-0.13</b>	<b>-0.75</b>		aver. cs,1	<b>180.09</b>	<b>181.00</b>
03.09.2018	09:38:00	-0.94	1.41	03.09.2018	09:53:00	184.69	179.69
	09:39:00	-0.47	1.88		09:54:00	180.63	179.38
	09:40:00	0.00	-0.16		09:55:00	178.75	179.84
	09:41:00	0.31	0.47		09:56:00	179.69	179.38
	09:42:00	0.63	0.63		09:57:00	180.00	179.38
	aver. cz,1	<b>-0.09</b>	<b>0.84</b>		aver. cs,1	<b>180.75</b>	<b>179.53</b>
17.09.2018	08:53:00	0.94	0.94	17.09.2018	09:08:00	184.69	184.53
	08:54:00	0.78	0.78		09:09:00	183.75	183.75
	08:55:00	0.63	0.63		09:10:00	182.66	182.66
	08:56:00	-0.31	-0.31		09:11:00	181.72	181.72
	08:57:00	-0.47	-0.47		09:12:00	182.19	181.72
	aver. cz,1	<b>0.31</b>	<b>0.31</b>		aver. cs,1	<b>183.00</b>	<b>182.88</b>

## 7.1 8.5.5 Reproducibility standard deviation or ozone under field conditions

*Reproducibility standard deviation under field conditions shall not exceed 5% of the mean value over a period of three months.*

### 7.2 Test procedures

The reproducibility standard deviation under field conditions is calculated from the measured hourly averaged data during the three-month period.

The difference  $\Delta x_{f,i}$  for each (ith) parallel measurement is calculated from:

$$\Delta x_{f,i} = x_{f,1,i} - x_{f,2,i}$$

Where:

$\Delta x_{f,i}$  is the ith difference in a parallel measurement;

$x_{f,1,i}$  is the ith measurement result of analyser 1;

$x_{f,2,i}$  is the ith measurement result of analyser 2;

The reproducibility standard deviation under field conditions is calculated according to:

$$s_{r,f} = \frac{\left( \sqrt{\frac{\sum_{i=1}^n \Delta x_{f,i}^2}{2 * n}} \right)}{c_f} \times 100$$

Where:

$s_{r,f}$  is the reproducibility standard deviation for NO2 under field conditions (%);

$n$  is the number of parallel measurements;

$c_f$  is the average concentration of ozone measured during the field test;

The reproducibility standard deviation under field conditions,  $s_{r,f}$ , shall comply with the performance criterion indicated above.

### 7.3 Testing

The reproducibility standard deviation under field conditions was calculated from the hourly averages over the field test period according to the equation stated above.

## 7.4 Evaluation

*Table 31: Determination of the reproducibility standard deviation on the basis of complete field test data*

reproducibility standard deviation in field		
no. of measurements (1h- average)	[n]	2353
average of both analyzers (3 month)	[nmol/mol]	28.28
standard deviation from paired measurements	[nmol/mol]	0.685
<b>reproducibility standard deviation in field <math>S_{r,f}</math></b>	<b>[%]</b>	<b>2.42</b>
requirement	$\leq 5,0 \%$	✓

The reproducibility standard deviation under field conditions is at 2.42% of the average.

## 7.5 Assessment

The reproducibility standard deviation for ozone under field conditions was 2.42% as a percentage of the mean value over the three-months field test period. Thus, the requirements of EN 14625 are satisfied.

Criterion satisfied? yes

## 7.6 Detailed presentation of test results

Figure 11 provides an illustration of the reproducibility standard deviation under field conditions.

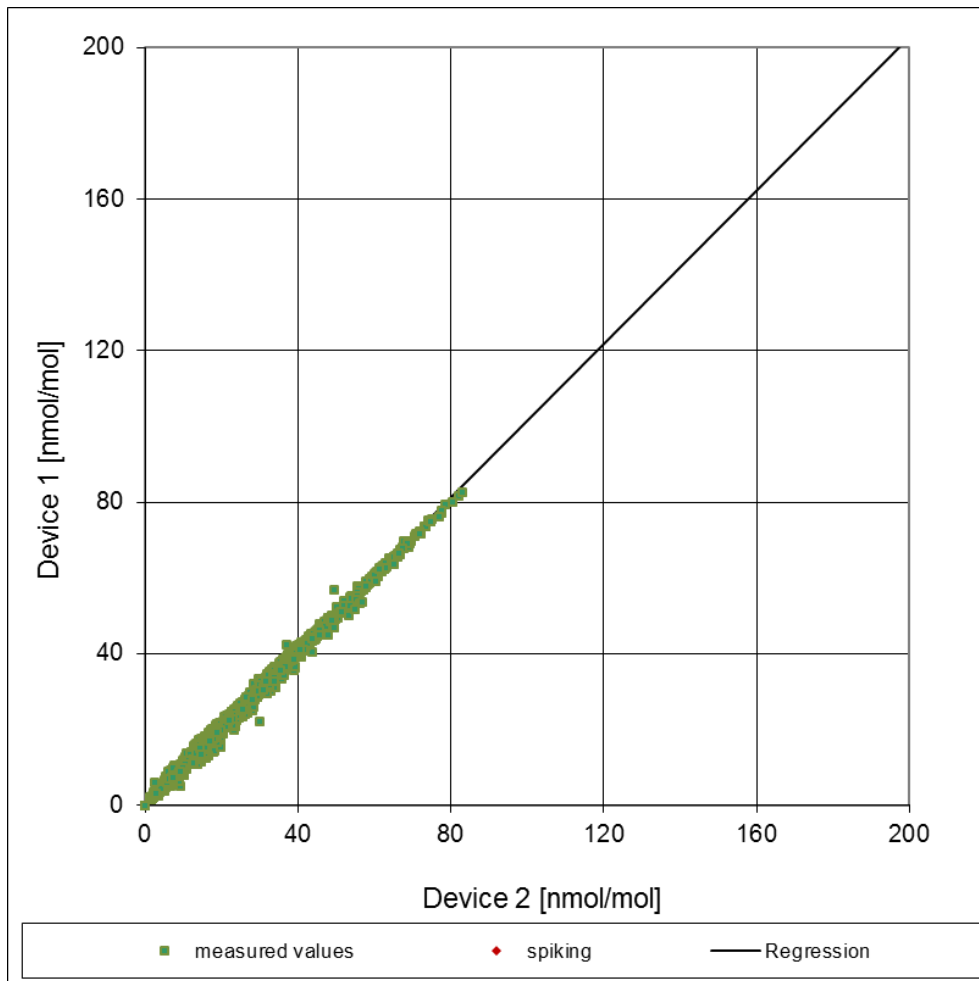


Figure 11: Diagram illustrating the reproducibility standard deviation under field conditions

## **7.1 8.5.6 Inspection interval**

*The period of unattended operation of the AMS shall be at least 2 weeks.*

## **7.2 Equipment**

Not required for this performance criterion

## **7.3 Testing**

With regard to this minimum requirement, the maintenance tasks required in a specific period and the length of that period for the correct functioning of the measuring system were identified. Furthermore, in determining the maintenance interval, the drift determined for zero and reference point in accordance with 7.1 8.5.4 Long-term drift have been taken into consideration.

## **7.4 Evaluation**

Over the entire period of the field test, no unacceptable drift was observed. The maintenance interval is thus determined by the necessary maintenance works.

During the three months field test period, maintenance is generally limited to contamination and plausibility checks and potential status/error messages. Naturally, the frequency of filter replacement will depend on the ambient dust concentration at the site of installation. Chapter 5 of the manual and Chapter 8 of this report provide information about tasks to be performed in the maintenance interval.

## **7.5 Assessment**

The necessary maintenance tasks determine the period of unattended operation. In essence, these include contamination checks, plausibility checks and checks of potential status/error warnings. The external particle filter needs replacing at the measurement site after having been subjected to dust loading. EN 14625 requires checking of zero and span points at least once every two weeks.

Criterion satisfied? yes

## **7.6 Detailed presentation of test results**

Not applicable in this instance.

## 7.1 8.5.7 Period of availability of the analyser

*Availability of the analyser shall be at least 90%.*

## 7.2 Test procedures

The correct operation of the analysers shall be checked at least every fourteen days. It is recommended to perform this check every day during the first fourteen days. These checks consist of plausibility checks on the measured values, as well as, when available, on status signals and other relevant parameters. Time, duration and nature of any malfunctioning shall be logged.

The total time period with useable measuring data is the period during the field test during which valid measuring data of the ambient air concentrations are obtained. In this time period, the time needed for calibrations, conditioning of sample systems and filters and maintenance shall not be included.

The availability of the analyser is calculated as:

$$A_a = \frac{t_u}{t_t} * 100$$

Where:

$A_a$  is the availability of the analyser (%);

$t_u$  is the total time period with validated measuring data;

$t_t$  is the time period of the field test minus the time for calibration, conditioning and maintenance,  $t_u$  and  $t_t$  shall be expressed in the same units.

The availability shall comply with the performance criterion indicated above.

### 7.3 Testing

Using the equation given above, the availability was calculated from the total period of the field test and the outage times which have occurred during this period.

#### Evaluation

Outage times which have occurred during the field test are listed in Table 32.

*Table 32: Availability of the 49iQ measuring system*

		System 1	System 2
Operation time	h	2353	2353
Outage time	h	0	0
Maintenance time	h	8	8
Actual operating time:	h	2345	2345
Actual operating time incl. maintenance times:	h	2353	2353
Availability	%	100	100

Maintenance times were caused by daily test gas feeding for the purpose of determining the drift behaviour and the maintenance interval and by times needed for replacing the Teflon filter built into the sample gas path.

### 7.5 Assessment

The availability is 100%. Thus, the requirement of EN 14625 is satisfied.

Criterion satisfied? yes

### 7.6 Detailed presentation of test results

Not applicable.



## 7.1 8.6 Calculation of the total uncertainty according to EN 14625 (2012)

The type approval of the analyser consists of the following steps:

- 1) The value of each individual performance characteristic tested in the laboratory shall fulfil the criterion stated in Table E.1 of standard EN 14625.
- 2) The expanded uncertainty calculated from the standard uncertainties due to the values of the specific performance characteristics obtained in the laboratory tests shall fulfil the criterion as stated in Annex I of Directive 2008/50/EC (15% for fixed measurements or 25% for indicative measurements). This criterion is the maximum uncertainty of individual measurements for continuous measurements at the 1-hour limit value. The relevant specific performance characteristics and the calculation procedure are given in Annex E of standard EN 14625.
- 3) The value of each of the individual performance characteristics tested in the field shall fulfil the criterion stated in Table E.1 of EN 14625.
- 4) The expanded uncertainty calculated from the standard uncertainties due to the values of the specific performance characteristics obtained in the laboratory and field tests shall fulfil the criterion as stated in Annex I of Directive 2008/50/EC (15% for fixed measurements or 25% for indicative measurements). This criterion is the maximum uncertainty of individual measurements for continuous measurements at the 1-hour limit value. The relevant specific performance characteristics and the calculation procedure are given in Annex E of standard EN 14625.

### 7.2 Equipment

Calculation of the total uncertainty in accordance with standard EN 14625 (2012), Annex E

### 7.3 Testing

At the end of the performance test, the total uncertainties were calculated from the values obtained during the test.

### 7.4 Evaluation

- Regarding 1) The value of each performance characteristic tested in the laboratory tests fulfils the criterion stated in Table E.1 of EN 14625.
- Regarding 2) The expanded uncertainty calculated from the standard uncertainties due to the values of the specific performance characteristics obtained in the laboratory tests fulfils the criterion as stated.
- Regarding 3) The value of each performance characteristic tested in the field tests fulfils the criterion stated in Table E.1 of EN 14625.
- Regarding 4) The expanded uncertainty calculated from the standard uncertainties due to the values of the specific performance characteristics obtained in the laboratory and field tests fulfils the criterion as stated.

### 7.5 Assessment

The requirement regarding the expanded uncertainty of the measuring system is complied with.

Criterion satisfied? yes

## 7.6 Detailed presentation of test results

Table 33 summarises the results for items 1 and 3.

Table 34 and Table 36 contain the results regarding item 2.

Table 35 and Table 37 contain the results regarding item 4.

*Table 33: Relevant performance characteristics and criteria according to EN 14625*

Performance characteristic	Performance criterion	Test result	Satisfied	Page
8.4.5 Repeatability standard deviation at zero	$\leq 1.0$ nmol/mol	S <sub>r</sub> system 1: 0.19 nmol/mol S <sub>r</sub> system 2: 0.20 nmol/mol	yes	78
8.4.5 Repeatability standard deviation at concentration level C <sub>t</sub>	$\leq 3.0$ nmol/mol	S <sub>r</sub> system 1: 0.34 nmol/mol S <sub>r</sub> system 2: 0.39 nmol/mol	yes	78
8.4.6 "Lack of fit" (deviation from the linear regression)	Largest deviation from the linear regression function $> 0, \leq 4.0\%$ of the reading Residual at zero: $\leq 5$ nmol/mol	X <sub>l,z</sub> system 1: ZP 1.28 nmol/mol X <sub>l</sub> system 1: RP 1.88% X <sub>l,z</sub> system 2: ZP 0.47 nmol/mol X <sub>l</sub> system 2: RP 1.48%	yes	81
8.4.7 Sensitivity coefficient of sample gas pressure	$\leq 2.0$ nmol/mol/kPa	b <sub>gp</sub> system 1: 0.20 nmol/mol/kPa b <sub>gp</sub> system 2: 0.14 nmol/mol/kPa	yes	86
8.4.8 Sensitivity coefficient of sample gas temperature	$\leq 1.0$ nmol/mol/K	b <sub>gt</sub> system 1: 0.09 nmol/mol/K b <sub>gt</sub> system 2: 0.05 nmol/mol/K	yes	88
8.4.9 Sensitivity coefficient of surrounding temperature	$\leq 1.0$ nmol/mol/K	b <sub>st</sub> system 1: 0.115 nmol/mol/K b <sub>st</sub> system 2: 0.091 nmol/mol/K	yes	90
8.4.10 Sensitivity coefficient of electrical voltage	$\leq 0.3$ nmol/mol/V	b <sub>v</sub> system 1: RP 0.02 nmol/mol/V b <sub>v</sub> system 2: RP 0.01 nmol/mol/V	yes	93
8.4.11 Interferent at zero and at concentration level c <sub>t</sub>	H <sub>2</sub> O $\leq 10.0$ nmol/mol Toluol $\leq 5.0$ nmol/mol M-Xylene $\leq 5.0$ nmol/mol	H <sub>2</sub> O system 1 ZP -2.03 nmol/mol / RP -1.67 nmol/mol system 2 ZP -0.89 nmol/mol / RP -0.47 nmol/mol Toluol system 1 ZP 1.46 nmol/mol / RP 4.27 nmol/mol system 2 ZP 2.24 nmol/mol / RP 4.05 nmol/mol M-Xylene system 1 ZP 2.30 nmol/mol / RP 4.75 nmol/mol system 2 ZP 2.45 nmol/mol / RP 4.63 nmol/mol	yes	95

Performance characteristic	Performance criterion	Test result	Satisfied	Page
8.4.12 Averaging effect	$\leq 7.0\%$ of the measured value	$E_{av}$ system 1: -5.4% $E_{av}$ system 2: -6.4%	yes	98
8.4.13 Difference sample/calibration port	$\leq 1.0\%$	$\Delta_{sc}$ system 1: 0.17% $\Delta_{sc}$ system 2: 0.08%	yes	101
8.4.3 Response time (rise)	$\leq 180$ s	$t_r$ system 1: 59 s $t_r$ system 2: 60.75 s	yes	70
8.4.3 Response time (fall)	$\leq 180$ s	$t_f$ system 1: 58.75 s $t_f$ system 2: 61.5 s	yes	70
8.4.3 Difference between the rise and fall response time	$\leq 10$ s	$t_d$ system 1: 0.3 s $t_d$ system 2: -0.7 s	yes	70
8.4.14 Residence time	$\leq 3.0$ s	system 1 1.0 s system 2 1.0 s	yes	103
8.5.7 Availability of the analyser	$> 90\%$	$A_a$ system 1: 100% $A_a$ system 2: 100%	yes	111
8.5.5 Reproducibility standard deviation under field conditions	$\leq 5.0\%$ of the average over a period of 3 months	$S_{r,f}$ system 1: 2.42% $S_{r,f}$ system 2: 2.42%	yes	107
8.5.4 Long-term drift at zero point	$\leq 5.0$ nmol/mol	$C_z$ system 1: 1.89 nmol/mol $C_z$ system 2: 1.65 nmol/mol	yes	104
8.5.4 Long-term drift at span level	$\leq 5.0\%$ of the upper limit of the certification range	$C_s$ system 1: max. -2.70% $C_s$ system 2: max. 1.81%	yes	104
8.4.4 Short-term drift at zero	$\leq 2.0$ nmol/mol over 12 h	$D_{s,z}$ system 1: -0.11 nmol/mol $D_{s,z}$ system 2: -0.30 nmol/mol	yes	74
8.4.4 Short-term drift at span level	$\leq 6.0$ nmol/mol over 12 h	$D_{s,s}$ system 1: -0.62 nmol/mol $D_{s,s}$ system 2: -0.25 nmol/mol	yes	74

**Table 34: Expanded uncertainty from the results obtained in the laboratory tests for analyser 1**

Measuring device:		49iQ		Serial-No.:		1180540009	
Measured component:		O <sub>3</sub>		1h-alert threshold:		120 nmol/mol	
No.	Performance characteristic	Performance criterion	Result	Partial uncertainty		Square of partial uncertainty	
1	Repeatability standard deviation at zero	≤ 1.0 nmol/mol	0.190	U <sub>r,z</sub>	0.05	0.0024	
2	Repeatability standard deviation at 1h-alert threshold	≤ 3.0 nmol/mol	0.340	U <sub>r,th</sub>	0.09	0.0077	
3	"lack of fit" at 1h-alert threshold	≤ 4.0% of measured value	1.880	U <sub>l,th</sub>	1.30	1.6965	
4	Sensitivity coefficient of sample gas pressure at 1h-alert threshold	≤ 2.0 nmol/mol/kPa	0.200	U <sub>sp</sub>	2.28	5.1939	
5	Sensitivity coefficient of sample gas temperature at 1h-alert threshold	≤ 1.0 nmol/mol/K	0.090	U <sub>st</sub>	0.98	0.9693	
6	Sensitivity coefficient of surrounding temperature at 1h-alert threshold	≤ 1.0 nmol/mol/K	0.115	U <sub>st</sub>	0.84	0.7034	
7	Sensitivity coefficient of electrical voltage at 1h-alert threshold	≤ 0.30 nmol/mol/V	0.020	U <sub>v</sub>	0.27	0.0752	
8a	Interferent H <sub>2</sub> O with 19 nmol/mol	≤ 10 nmol/mol (Zero)	-2.030	U <sub>H2O</sub>	-1.25	1.5528	
		≤ 10 nmol/mol (Span)	-1.670				
8b	Interferent Toluene with 0,5 µmol/mol	≤ 5.0 nmol/mol (Zero)	1.460	U <sub>int,pos</sub>	5.21	27.1201	
		≤ 5.0 nmol/mol (Span)	4.270				
8c	Interferent Xylene with 0,5 µmol/mol	≤ 5.0 nmol/mol (Zero)	2.300	U <sub>int,reg</sub>			
		≤ 5.0 nmol/mol (Span)	4.750				
9	Averaging effect	≤ 7.0% of measured value	-5.400	U <sub>av</sub>	-3.74	13.9968	
18	Difference sample/calibration port	≤ 1.0%	0.170	U <sub>ssc</sub>	0.20	0.0416	
21	Uncertainty of test gas	≤ 3.0%	2.000	U <sub>cg</sub>	1.20	1.4400	
Combined standard uncertainty				U <sub>c</sub>		7.2663	nmol/mol
Expanded uncertainty				U		14.5327	nmol/mol
Relative expanded uncertainty				W		12.11	%
Maximum allowed expanded uncertainty				W <sub>req</sub>		15	%

**Table 35: Expanded uncertainty from the results obtained in the laboratory and field tests for analyser 1**

Measuring device:		49iQ		Serial-No.:		1180540009	
Measured component:		O <sub>3</sub>		1h-alert threshold:		120 nmol/mol	
No.	Performance characteristic	Performance criterion	Result	Partial uncertainty		Square of partial uncertainty	
1	Repeatability standard deviation at zero	≤ 1.0 nmol/mol	0.190	U <sub>r,z</sub>	0.05	0.0024	
2	Repeatability standard deviation at 1h-alert threshold	≤ 3.0 nmol/mol	0.340	U <sub>r,th</sub>	not considered, as u <sub>r,th</sub> = 0.08 < u <sub>r,f</sub>	-	
3	"lack of fit" at 1h-alert threshold	≤ 4.0% of measured value	1.880	U <sub>l,th</sub>	1.30	1.6965	
4	Sensitivity coefficient of sample gas pressure at 1h-alert threshold	≤ 2.0 nmol/mol/kPa	0.200	U <sub>sp</sub>	2.28	5.1939	
5	Sensitivity coefficient of sample gas temperature at 1h-alert threshold	≤ 1.0 nmol/mol/K	0.090	U <sub>st</sub>	0.98	0.9693	
6	Sensitivity coefficient of surrounding temperature at 1h-alert threshold	≤ 1.0 nmol/mol/K	0.115	U <sub>st</sub>	0.84	0.7034	
7	Sensitivity coefficient of electrical voltage at 1h-alert threshold	≤ 0.30 nmol/mol/V	0.020	U <sub>v</sub>	0.27	0.0752	
8a	Interferent H <sub>2</sub> O with 19 nmol/mol	≤ 10 nmol/mol (Zero)	-2.030	U <sub>H2O</sub>	-1.25	1.5528	
		≤ 10 nmol/mol (Span)	-1.670				
8b	Interferent Toluene with 0,5 µmol/mol	≤ 5.0 nmol/mol (Zero)	1.460	U <sub>int,pos</sub>	5.21	27.1201	
		≤ 5.0 nmol/mol (Span)	4.270				
8c	Interferent Xylene with 0,5 µmol/mol	≤ 5.0 nmol/mol (Zero)	2.300	U <sub>int,reg</sub>			
		≤ 5.0 nmol/mol (Span)	4.750				
9	Averaging effect	≤ 7.0% of measured value	-5.400	U <sub>av</sub>	-3.74	13.9968	
10	Reproducibility standard deviation under field conditions	≤ 5.0% of average over 3 months	2.420	U <sub>r,f</sub>	2.90	8.4332	
11	Long term drift at zero level	≤ 5.0 nmol/mol	1.890	U <sub>d,z</sub>	1.09	1.1907	
12	Long term drift at span level	≤ 5.0% of max. of certification range	-2.700	U <sub>d,th</sub>	-1.87	3.4992	
18	Difference sample/calibration port	≤ 1.0%	0.170	U <sub>ssc</sub>	0.20	0.0416	
21	Uncertainty of test gas	≤ 3.0%	2.000	U <sub>cg</sub>	1.20	1.4400	
Combined standard uncertainty				U <sub>c</sub>		8.1188	nmol/mol
Expanded uncertainty				U		16.2376	nmol/mol
Relative expanded uncertainty				W		13.53	%
Maximum allowed expanded uncertainty				W <sub>req</sub>		15	%

Report on the performance test of the 49IQ ambient air quality measuring system for Ozone manufactured by Thermo Fisher Scientific  
Report No.: 936/21242986/A

Page 117 of 396

**Table 36:** Expanded uncertainty from the results obtained in the laboratory tests for analyser 2

Measuring device:		49IQ		Serial-No.:		1180540010	
Measured component:		O <sub>3</sub>		1h-alert threshold:		120 nmol/mol	
No.	Performance characteristic	Performance criterion	Result	Partial uncertainty		Square of partial uncertainty	
1	Repeatability standard deviation at zero	≤ 1.0 nmol/mol	0.200	u <sub>r,z</sub>	0.05	0.0027	
2	Repeatability standard deviation at 1h-alert threshold	≤ 3.0 nmol/mol	0.390	u <sub>r,1h</sub>	0.10	0.0106	
3	"lack of fit" at 1h-alert threshold	≤ 4.0% of measured value	1.480	u <sub>l,1h</sub>	1.03	1.0514	
4	Sensitivity coefficient of sample gas pressure at 1h-alert threshold	≤ 2.0 nmol/mol/kPa	0.140	u <sub>sp</sub>	1.62	2.6192	
5	Sensitivity coefficient of sample gas temperature at 1h-alert threshold	≤ 1.0 nmol/mol/K	0.050	u <sub>st</sub>	0.55	0.2992	
6	Sensitivity coefficient of surrounding temperature at 1h-alert threshold	≤ 1.0 nmol/mol/K	0.091	u <sub>st</sub>	0.66	0.4404	
7	Sensitivity coefficient of electrical voltage at 1h-alert threshold	≤ 0.30 nmol/mol/V	0.010	u <sub>v</sub>	0.14	0.0194	
8a	Interferent H <sub>2</sub> O with 19 mmol/mol	≤ 10 nmol/mol (Zero)	-0.890	u <sub>H2O</sub>	-0.35	0.1230	
		≤ 10 nmol/mol (Span)	-0.470				
8b	Interferent Toluene with 0,5 µmol/mol	≤ 5.0 nmol/mol (Zero)	2.240	u <sub>int,pos</sub>	5.01	25.1141	
		≤ 5.0 nmol/mol (Span)	4.050				
8c	Interferent Xylene with 0,5 µmol/mol	≤ 5.0 nmol/mol (Zero)	2.450	u <sub>int,neg</sub>	5.01	25.1141	
		≤ 5.0 nmol/mol (Span)	4.630				
9	Averaging effect	≤ 7.0% of measured value	-6.400	u <sub>av</sub>	-4.43	19.6608	
18	Difference sample/calibration port	≤ 1.0%	0.080	u <sub>disc</sub>	0.10	0.0092	
21	Uncertainty of test gas	≤ 3.0%	2.000	u <sub>cg</sub>	1.20	1.4400	
				Combined standard uncertainty		u <sub>c</sub>	7.1267 nmol/mol
				Expanded uncertainty		U	14.2534 nmol/mol
				Relative expanded uncertainty		W	11.88 %
				Maximum allowed expanded uncertainty		W <sub>req</sub>	15 %

**Table 37:** Expanded uncertainty from the results obtained in the laboratory and field tests for analyser 2

Measuring device:		49IQ		Serial-No.:		1180540010	
Measured component:		O <sub>3</sub>		1h-alert threshold:		120 nmol/mol	
No.	Performance characteristic	Performance criterion	Result	Partial uncertainty		Square of partial uncertainty	
1	Repeatability standard deviation at zero	≤ 1.0 nmol/mol	0.200	u <sub>r,z</sub>	0.05	0.0027	
2	Repeatability standard deviation at 1h-alert threshold	≤ 3.0 nmol/mol	0.390	u <sub>r,1h</sub>	not considered, as u <sub>r,1h</sub> = 0, 1 < u <sub>r,f</sub>	-	
3	"lack of fit" at 1h-alert threshold	≤ 4.0% of measured value	1.480	u <sub>l,1h</sub>	1.03	1.0514	
4	Sensitivity coefficient of sample gas pressure at 1h-alert threshold	≤ 2.0 nmol/mol/kPa	0.140	u <sub>sp</sub>	1.62	2.6192	
5	Sensitivity coefficient of sample gas temperature at 1h-alert threshold	≤ 1.0 nmol/mol/K	0.050	u <sub>st</sub>	0.55	0.2992	
6	Sensitivity coefficient of surrounding temperature at 1h-alert threshold	≤ 1.0 nmol/mol/K	0.091	u <sub>st</sub>	0.66	0.4404	
7	Sensitivity coefficient of electrical voltage at 1h-alert threshold	≤ 0.30 nmol/mol/V	0.010	u <sub>v</sub>	0.14	0.0194	
8a	Interferent H <sub>2</sub> O with 19 mmol/mol	≤ 10 nmol/mol (Zero)	-0.890	u <sub>H2O</sub>	-0.35	0.1230	
		≤ 10 nmol/mol (Span)	-0.470				
8b	Interferent Toluene with 0,5 µmol/mol	≤ 5.0 nmol/mol (Zero)	2.240	u <sub>int,pos</sub>	5.01	25.1141	
		≤ 5.0 nmol/mol (Span)	4.050				
8c	Interferent Xylene with 0,5 µmol/mol	≤ 5.0 nmol/mol (Zero)	2.450	u <sub>int,neg</sub>	5.01	25.1141	
		≤ 5.0 nmol/mol (Span)	4.630				
9	Averaging effect	≤ 7.0% of measured value	-6.400	u <sub>av</sub>	-4.43	19.6608	
10	Reproducibility standard deviation under field conditions	≤ 5.0% of average over 3 months	2.420	u <sub>r,f</sub>	2.90	8.4332	
11	Long term drift at zero level	≤ 5.0 nmol/mol	1.650	u <sub>d,z</sub>	0.95	0.9075	
12	Long term drift at span level	≤ 5.0% of max. of certification range	1.810	u <sub>d,1h</sub>	1.25	1.5725	
18	Difference sample/calibration port	≤ 1.0%	0.080	u <sub>disc</sub>	0.10	0.0092	
21	Uncertainty of test gas	≤ 3.0%	2.000	u <sub>cg</sub>	1.20	1.4400	
				Combined standard uncertainty		u <sub>c</sub>	7.8545 nmol/mol
				Expanded uncertainty		U	15.7089 nmol/mol
				Relative expanded uncertainty		W	13.09 %
				Maximum allowed expanded uncertainty		W <sub>req</sub>	15 %

## 8. Recommendations for use in practice

### Work in the maintenance interval

The tested measuring systems require regular performance of the following tasks:

- Regular visual inspections/telemetric inspections
- Instrument status ok
- No error messages
- Replace the external Teflon filter at the sample gas inlet as required by measurement site conditions;
- Perform zero and reference checks using suitable test gas every two weeks in accordance with standard EN 14625;

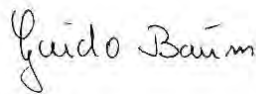
Other than that, follow the manufacturer's instructions indicated in the user manual.

Environmental Protection/Air Pollution Control



---

Dipl.-Ing. Martin Schneider



---

Dipl.-Ing. Guido Baum

Cologne, 2 October 2018  
936/21242986/A

## **9. Bibliography**

- [1] VDI 4202 part 1: Performance test, declaration of suitability, and certification of point-related measuring systems for gaseous air pollutants of April 2018
- [2] European standard EN 14625: Ambient air - Standard method for the measurement of the concentration of ozone by ultraviolet photometry of August 2012
- [3] Directive 2008/50/EG of the European Parliament and of the Council of 21 May 2008 on ambient air quality and cleaner air for Europe.

## **10. Appendices**

**Appendix 1      Certificate of Accreditation to EN ISO/IEC 17025:2005**

**Annex 2         Manual**





## Deutsche Akkreditierungsstelle GmbH

Beliehene gemäß § 8 Absatz 1 AkkStelleG i.V.m. § 1 Absatz 1 AkkStelleGBV  
Unterzeichnerin der Multilateralen Abkommen  
von EA, ILAC und IAF zur gegenseitigen Anerkennung

## Akkreditierung



Die Deutsche Akkreditierungsstelle GmbH bestätigt hiermit, dass das Prüflaboratorium

### TÜV Rheinland Energy GmbH

mit seinen in der Urkundenanlage aufgeführten Messstellen


die Kompetenz nach DIN EN ISO/IEC 17025:2005 besitzt, Prüfungen in folgenden Bereichen durchzuführen:

Bestimmung (Probenahme und Analytik) von anorganischen und organischen gas- oder partikel-förmigen Luftinhaltsstoffen im Rahmen von Emissions- und Immissionsmessungen; Probenahme von luftgetragenen polyhalogenierten Dibenzo-p-Dioxinen und Dibenzofuranen bei Emissionen und Immissionen; Probenahme von faserförmigen Partikeln bei Emissionen und Immissionen; Ermittlung von gas- oder partikelförmigen Luftinhaltsstoffen mit kontinuierlich arbeitenden Messgeräten; Bestimmung von Geruchsstoffen in Luft; Kalibrierungen und Funktionsprüfungen kontinuierlich arbeitender Messgeräte für Luftinhaltsstoffe einschließlich Systemen zur Datenauswertung und Emissionsfernüberwachung; Feuerraummessungen; Eignungsprüfungen von automatisch arbeitenden Emissions- und Immissionsmeseinrichtungen einschließlich Systemen zur Datenauswertung und Emissionsfernüberwachung; Ermittlung der Emissionen und Immissionen von Geräuschen; Ermittlung von Geräuschen und Vibrationen am Arbeitsplatz; akustische und schwingungstechnische Messungen im Eisenbahnwesen; Bestimmung von Schalleistungspegeln von zur Verwendung im Freien vorgesehenen Geräten und Maschinen nach Richtlinie 2000/14/EG und Konformitätsbewertungsverfahren; Schornsteinhöhenberechnung und Immissionsprognose auf der Grundlage der Technischen Anleitung zur Reinhaltung der Luft und der Geruchsimmissions-Richtlinie und der VDI 3783 Blatt 13; Windenergieanlagen: Bestimmung von Windpotential, Energieerträgen, Standorterträgen und Standortgüte nach EEG, standortbezogenen Turbulenzcharakteristika und Extremwinde; Schallimmissionsprognosen, Schattenwurfimmissionsberechnung und Sichtbarkeitsbestimmung; Probenahme und mikrobiologische Untersuchungen von Nutzwasser gemäß §3 Absatz 8 42. BImSchV; physikalische, physikalisch-chemische und mikrobiologische Untersuchungen von Wasser (Abwasser, Wasser aus Rückkühlwerken sowie raumlufttechnischen Anlagen); Probenahme von Abwasser; mikrobiologische und ausgewählte chemische Untersuchungen gemäß Trinkwasserverordnung; Probenahme von Roh- und Trinkwasser; ausgewählte mikrobiologische Untersuchungen von Bedarfsgegenständen und kosmetischen Mitteln; Probenahme anorganischer faserförmiger Partikel sowie von partikel- und gasförmigen luftverunreinigenden Stoffen in der Innenraumluft; ausgewählte mikrobiologische Untersuchungen in Innenräumen; Ermittlung von Aerosolen und Faserstäuben, anorganischen und organischen Gasen und Dämpfen sowie ausgewählten Parametern und/oder in ausgewählten Gebieten bei Arbeitsplatzmessungen gemäß Gefahrstoffverordnung §7, Abs. 10; Modul Immissionsschutz

Die Akkreditierungsurkunde gilt nur in Verbindung mit dem Bescheid vom 02.08.2018 mit der Akkreditierungsnummer D-PL-11120-02-00 und ist gültig bis 10.12.2022. Sie besteht aus diesem Deckblatt, der Rückseite des Deckblatts und der folgenden Anlage mit insgesamt 55 Seiten.

Registrierungsnummer der Urkunde: **D-PL-11120-02-00**

Berlin, 02.08.2018

  
Im Auftrag Dipl.-Ing. Andrea Valbuena  
Abteilungsleiterin

Siehe Hinweise auf der Rückseite

Figure 12: Certificate of accreditation according to EN ISO/IEC 17025:2005

## Deutsche Akkreditierungsstelle GmbH

Standort Berlin  
Spittelmarkt 10  
10117 Berlin

Standort Frankfurt am Main  
Europa-Allee 52  
60327 Frankfurt am Main

Standort Braunschweig  
Bundesallee 100  
38116 Braunschweig

Die auszugsweise Veröffentlichung der Akkreditierungsurkunde bedarf der vorherigen schriftlichen Zustimmung der Deutsche Akkreditierungsstelle GmbH (DAkkS). Ausgenommen davon ist die separate Weiterverbreitung des Deckblattes durch die umseitig genannte Konformitätsbewertungsstelle in unveränderter Form.

Es darf nicht der Anschein erweckt werden, dass sich die Akkreditierung auch auf Bereiche erstreckt, die über den durch die DAkkS bestätigten Akkreditierungsbereich hinausgehen.

Die Akkreditierung erfolgte gemäß des Gesetzes über die Akkreditierungsstelle (AkkStelleG) vom 31. Juli 2009 (BGBl. I S. 2625) sowie der Verordnung (EG) Nr. 765/2008 des Europäischen Parlaments und des Rates vom 9. Juli 2008 über die Vorschriften für die Akkreditierung und Marktüberwachung im Zusammenhang mit der Vermarktung von Produkten (Abl. L 218 vom 9. Juli 2008, S. 30). Die DAkkS ist Unterzeichnerin der Multilateralen Abkommen zur gegenseitigen Anerkennung der European co-operation for Accreditation (EA), des International Accreditation Forum (IAF) und der International Laboratory Accreditation Cooperation (ILAC). Die Unterzeichner dieser Abkommen erkennen ihre Akkreditierungen gegenseitig an.

Der aktuelle Stand der Mitgliedschaft kann folgenden Webseiten entnommen werden:

EA: [www.european-accreditation.org](http://www.european-accreditation.org)

ILAC: [www.ilac.org](http://www.ilac.org)

IAF: [www.iaf.nu](http://www.iaf.nu)

**Figure 12:** Certificate of accreditation according to EN ISO/IEC 17025:2005 - page 2

# **Annex 1:**

## **Manual**



# 43iQ Instruction Manual

Sulfur Dioxide Analyzer

117568-00 • 15Jan2018



# Contents

<b>Chapter 1</b>	<b>Introduction.....</b>	<b>1-1</b>
	iQ Series Instrument Platform.....	1-1
	43iQ Principle of Operation .....	1-3
	Specifications .....	1-5
	Dimensions.....	1-7
<b>Chapter 2</b>	<b>Installation and Setup.....</b>	<b>2-1</b>
	Unpacking and Inspection .....	2-1
	Cover Removing and Replacing .....	2-2
	Mounting Options.....	2-3
	Bench Mount.....	2-3
	Rack Mount.....	2-4
	Setup Procedure.....	2-6
	Startup.....	2-8
<b>Chapter 3</b>	<b>Operation.....</b>	<b>3-1</b>
	Instrument Display .....	3-1
	Main Menus and Keypads.....	3-5
	Numeric Keypad.....	3-6
	Alphanumeric Keypad.....	3-7
	Calibration.....	3-9
	Calibrate Background.....	3-11
	Calibrate Span Coefficient .....	3-12
	Zero/Span Schedule .....	3-14
	Advanced Calibration.....	3-16
	Manual Calibration.....	3-17
	Calibration History .....	3-22
	Data.....	3-23
	View Data Log (Last Hour).....	3-24
	View Data Log (Last 24 Hours) .....	3-25
	View Data Log (User Defined Time) .....	3-26
	Advanced Data Setup.....	3-28
	Data Logging Setup .....	3-29
	Select Data Logging Variables .....	3-30
	Streaming Data Setup .....	3-32
	Select Streaming Variables.....	3-33
	Settings .....	3-35
	Health Check.....	3-36

Status and Alarms.....	3-37
Valve and Pump Resets .....	3-48
Predictive Diagnostics .....	3-54
Maintenance .....	3-55
Preventive Maintenance .....	3-56
Change Part .....	3-58
Maintenance History.....	3-59
File Sharing and Support.....	3-60
Measurement Settings .....	3-61
Averaging Time.....	3-63
Range Mode Selection.....	3-65
Range Setting.....	3-67
Gas Mode .....	3-68
Gas Units .....	3-69
Advanced Measurement Settings.....	3-70
Communications .....	3-76
Wired TCP/DHCP .....	3-77
Serial RS-232/485 .....	3-79
Analog I/O.....	3-80
Digital I/O.....	3-81
Email Server (SMTP).....	3-82
Instrument Settings.....	3-83
Display Setup.....	3-84
Alarm Setpoints.....	3-85
Clock .....	3-87
Date / Time Parameters .....	3-88
Time Zone.....	3-89
Time Server.....	3-91
Date Format.....	3-92
Configuration .....	3-93
Security Access Levels.....	3-94
Change Security to View Only Access .....	3-96
Change Full Access Security Password.....	3-97
USB Drive .....	3-99
Firmware Update Via USB Drive.....	3-100
Download Data To USB Drive.....	3-101
Change USB Password.....	3-104
User Contact Information.....	3-106
Update Bootloader.....	3-107

<b>Chapter 4</b>	<b>Calibration .....</b>	<b>4-1</b>
	Equipment Required.....	4-1
	Zero Air Generation.....	4-2
	Commercial Heatless Air Dryers .....	4-2
	Absorbing Column.....	4-2
	SO <sub>2</sub> Concentration Standard.....	4-2

	Calibration Gas Generation .....	4-2
	Cylinder Gas Dilution.....	4-3
	External Flow Meter(s) and Controller(s).....	4-3
	Commercial Precision Dilution Systems.....	4-4
	Permeation Tube System.....	4-4
	Commercial Permeation Systems .....	4-5
	Calibration .....	4-6
	Calibration in Dual/Auto Range Mode .....	4-8
	Zero and Span Check.....	4-10
	Manual Calibration .....	4-11
	Adjust Background.....	4-12
	Adjust Span Coefficient.....	4-12
	Reset Bkg to 0.000 and Span Coef to 1.000.....	4-13
	Zero/Span Schedule .....	4-14
	Next Time .....	4-14
	Period .....	4-14
	Zero/Span/Purge Duration Minutes .....	4-14
	Schedule Averaging Time.....	4-15
	Background Calibration and Span Calibration .....	4-15
	Zero/Span Ratio.....	4-15
	References .....	4-15
<b>Chapter 5</b>	<b>Maintenance.....</b>	<b>5-1</b>
	Safety Precautions .....	5-1
	Fan Filter Inspection and Cleaning .....	5-1
	Pump Rebuilding.....	5-2
	Leak Test .....	5-5
	Lamp Voltage Check.....	5-6
	Lamp Voltage Adjustment.....	5-6
<b>Chapter 6</b>	<b>Troubleshooting .....</b>	<b>6-1</b>
	Safety Precautions .....	6-1
	Troubleshooting Guide.....	6-1
<b>Chapter 7</b>	<b>Servicing.....</b>	<b>7-1</b>
	Safety Precautions .....	7-1
	Firmware Updates .....	7-3
	Replacement Parts List .....	7-3
	Fuse Replacement .....	7-5
	Filter Replacement .....	7-6
	Fan Replacement.....	7-7
	Measurement Side Removal and Replacing.....	7-9
	LCD Module Replacement .....	7-12
	I/O Replacement.....	7-14



Peripherals Support Board and System Controller Board Replacement .....	7-16
DMC Pressure and Flow Board .....	7-17
Pump Replacement .....	7-19
Capillary Cleaning and/or Replacement .....	7-22
Capillary O-Ring Replacement .....	7-24
Power Supply Replacement .....	7-24
Step POL Board Replacement .....	7-26
DMC Optical Bench Removal .....	7-29
Optical Bench Assembly Removal .....	7-29
Optical Bench Assembly Removal .....	7-31
Photomultiplier Tube (PMT) Replacement .....	7-33
Flasher Pack Replacement .....	7-35
Flasher Pack Lamp Replacement .....	7-36
Photo Lamp Detector Board Replacement .....	7-37
Kicker Assembly Replacement .....	7-39
Optional Manifold Replacement .....	7-40
Optional DMC Permeation Oven Solenoid Valve Replacement .....	7-42
Permeation Oven Replacement .....	7-44
Permeation Oven Board Replacement .....	7-47

**Chapter 8**

<b>System Description .....</b>	<b>8-1</b>
Optical Bench DMC .....	8-2
Heated Hydrocarbon Kicker .....	8-2
Optical Bench Hardware .....	8-2
Condensing Lens .....	8-2
Mirror Assembly .....	8-2
Light Baffle .....	8-2
Bandpass Filter .....	8-2
Flash Lamp Trigger Assembly .....	8-3
Flash Lamp .....	8-3
Flash Trigger Board .....	8-3
Flash Intensity Assembly .....	8-3
Photomultiplier Tube .....	8-3
Optical Bench DMC Board .....	8-3
Bench Heater .....	8-4
Permeation Oven (Optional) .....	8-4
Common Electronics .....	8-4
Power Supply .....	8-7
Front Panel .....	8-7
I/O and Communication Components .....	8-7
System Controller Board .....	8-7
Backplane Board .....	8-7
Peripherals Support System .....	8-8
Fan .....	8-8
STEP POL Board .....	8-8

	Sample Pump.....	8-8
	Solenoid Valve Panel.....	8-8
	Flow/Pressure DMC .....	8-8
	Firmware.....	8-8
<b>Chapter 9</b>	<b>Optional Equipment .....</b>	<b>9-1</b>
	Connecting External Devices .....	9-1
	Communication Board .....	9-2
	RS-232/RS-485 Port.....	9-2
	RS-485 External Accessory Port .....	9-3
	Analog I/O Board .....	9-4
	Analog Voltage Inputs.....	9-4
	Analog Voltage Outputs.....	9-5
	Analog Output Calibration .....	9-6
	Analog Output Zero Calibration.....	9-7
	Analog Output Full Scale Calibration .....	9-9
	Digital I/O Board.....	9-11
	Digital Inputs.....	9-11
	Digital Relay Switches.....	9-13
	Valve Driver Outputs.....	9-15
	Internal Zero/Span and Sample Valves.....	9-17
	Internal Permeation Span Source .....	9-17
	Permeation Tube Installation .....	9-19
	Computation of Concentrations .....	9-22
	PTFE Particulate Filter .....	9-23
<b>Appendix A</b>	<b>Safety, Warranty, and WEEE.....</b>	<b>A-1</b>
	Safety .....	A-1
	Safety and Equipment Damage Alerts .....	A-1
	Warranty.....	A-2
	WEEE Compliance.....	A-4
	WEEE Symbol.....	A-4
<b>Appendix B</b>	<b>Quick Reference .....</b>	<b>B-1</b>
	List of Figures .....	B-1
	List of Tables.....	B-3
<b>Appendix C</b>	<b>GNU Lesser General Public License.....</b>	<b>C-1</b>
	GNU Lesser General Public License.....	C-1



# Chapter 1

## Introduction

The Thermo Scientific™ 43iQ Sulfur Dioxide (SO<sub>2</sub>) utilizes pulsed fluorescence technology to measure the amount of sulphur dioxide in the air.

The pulsing of the UV source lamp serves to increase the optical intensity whereby a greater UV energy throughput and lower detectable SO<sub>2</sub> concentration are realized.

Reflective bandpass filters, as compared to commonly used transmission filters, are less subject to photochemical degradation and more selective in wavelength isolation. This results in both increased detection specificity and long term stability.

### **iQ Series Instrument Platform**

The iQ Series Instrument Platform is a smart environmental monitoring solution for ambient and source gas analysis that affords greater control over instrument performance and data availability.

- Distributed Measurement and Control (DMC) module design simplifies serviceability. Each DMC module contains its own microprocessor control enabling functional performance validation at the module level.
- Built-in predictive diagnostics and preventive maintenance schedules identify problems before they occur. The iQ Series platform sends email notifications directly to Thermo Fisher Scientific's world class service support team or locally identified addressees in order to proactively communicate analyzer performance conditions and identify spare parts needs before an operational concern arises.
- The iQ Series platform supports Modbus, streaming and VNC protocols over serial and Ethernet as well as analog and digital I/O for easy integration into most data management systems.
- Three standard USB ports afford convenient data download capability as well as the ability to connect additional hardware, such as a computer keyboard or mouse.
- The iQ Series GUI runs on a 7" color touchscreen display. The GUI is highly flexible and can be customized to enable a tailored

## Introduction

iQ Series Instrument Platform

experience to simplify daily operations. Custom designed ePort software allows remote access to the analyzer with a PC. The ePort control mirrors the same GUI look and feel as the instrument touchscreen providing a speedy and familiar operational experience.



**Figure 1–1.** 43iQ Front

## 43iQ Principle of Operation

The 43iQ operates on the principle that SO<sub>2</sub> molecules absorb ultraviolet (UV) light and become excited at one wavelength, then decay to a lower energy state emitting UV light at a different wavelength. Specifically,

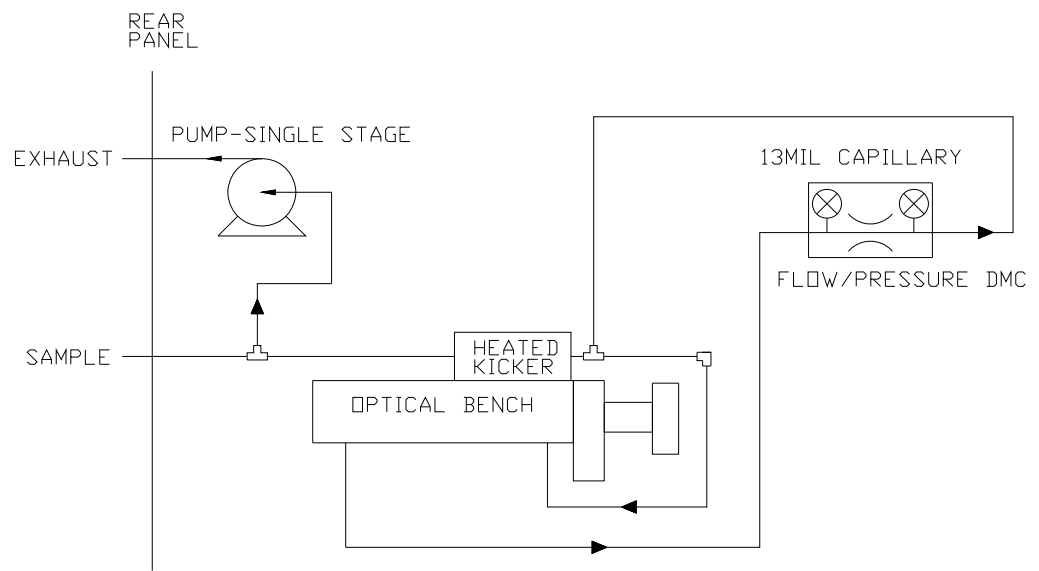


The sample is drawn into the 43iQ through the SAMPLE bulkhead, as shown in [Figure 1–2](#). The sample flows through a hydrocarbon “kicker,” which removes hydrocarbons from the sample by forcing the hydrocarbon molecules to permeate through the tube wall. The SO<sub>2</sub> molecules pass through the hydrocarbon “kicker” unaffected.

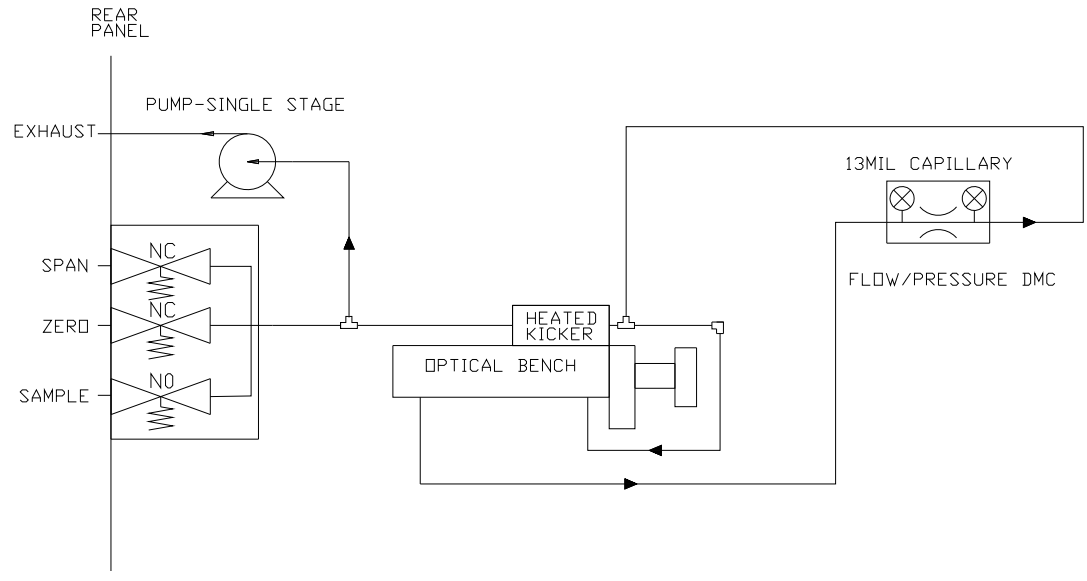
The sample then flows into the fluorescence chamber, where pulsating UV light excites the SO<sub>2</sub> molecules. The condensing lens focuses the pulsating UV light into the mirror assembly. The mirror assembly contains four selective mirrors that reflect only the wavelengths which excite SO<sub>2</sub> molecules.

As the excited SO<sub>2</sub> molecules decay to lower energy states they emit UV light that is proportional to the SO<sub>2</sub> concentration. The bandpass filter allows only the wavelengths emitted by the excited SO<sub>2</sub> molecules to reach the photomultiplier tube (PMT). The PMT detects the UV light emission from the decaying SO<sub>2</sub> molecules. The photodetector, located at the back of the fluorescence chamber, continuously monitors the pulsating UV light source and is connected to a circuit that compensates for fluctuations in the UV light.

As the sample leaves the optical chamber, it passes through a flow sensor, a capillary, and the “shell” side of the hydrocarbon kicker. The sample then flows to the pump and is exhausted out the EXHAUST bulkhead of the analyzer. The 43iQ outputs the SO<sub>2</sub> concentration to the front panel display and the analog outputs, and also makes the data available over the serial or Ethernet connection.



**Figure 1-2.** 43iQ Flow Schematic



**Figure 1-3.** 43iQ Flow Schematic with Zero Span

## Specifications

Table 1–1 lists the specifications for the 43iQ.

**Table 1–1.** 43iQ Specifications

Range	0–10 ppm 0–25 mg/m <sup>3</sup>
Extended Ranges	0–100 ppm 0–250 mg/m <sup>3</sup>
Zero Noise	1.0 ppb RMS (10 second averaging time) 0.5 ppb RMS (60 second averaging time) 0.25 ppb RMS (300 second averaging time)
Detection Limit	2 ppb (10 second averaging time) 1 ppb (60 second averaging time) 0.25 ppb (300 second averaging time)
Zero Drift	<0.5 ppb (24 hour)
Span Drift	±0.5% full-scale (24 hour)
Response Time	60 sec (10 second averaging time) 110 sec (60 second averaging time) 320 sec (300 second averaging time)
Linearity	±1% full-scale
Flow Rate	0.5 lpm (standard)
Interferences (EPA levels)	Less than lower detectable limit except for the following: NO < 3 ppb, M-Xylene < 1ppb, H <sub>2</sub> O < 3% of reading
Operating Temperature Range	0–45 °C
Power Requirements	100–240 VAC 50/60 Hz 275 watts
Physical Dimensions	24 in (D) x 16.75 in (W) x 8.72 in (H) [609 mm (D) 425.45 mm (W) x 221.48 mm (H)]
Weight	37.1 lbs
Analog I/O	4 Isolated Voltage Inputs 0–10 V 6 Isolated Analog Voltages Outputs, with 4 selectable ranges 6 Isolated Analog Current Outputs, with 2 selectable ranges
Digital I/O	16 Digital Inputs (TTL) 8 Solenoid Driver Outputs 10 Digital Reed Relay Contact Outputs
Serial Ports	1 RS-232/485 port

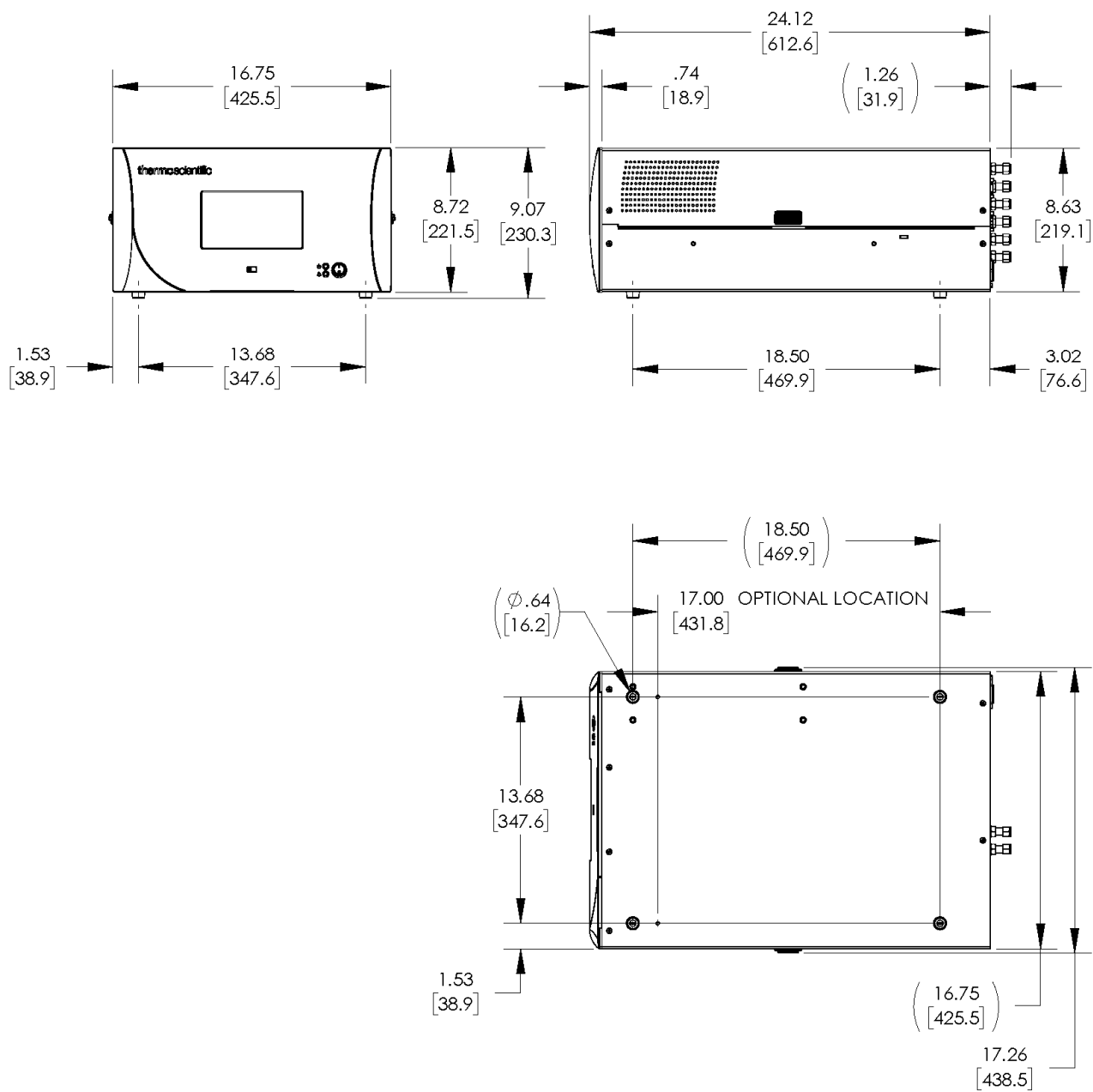


	1 RS-485 External Accessory port
Other Ports	3 Full Speed USB ports (one in front, two in rear) 1 Gigabit Ethernet port
Communication Protocols	MODBUS, Streaming
Approvals and Certifications	CE, TUV-SUD Safety, EPA

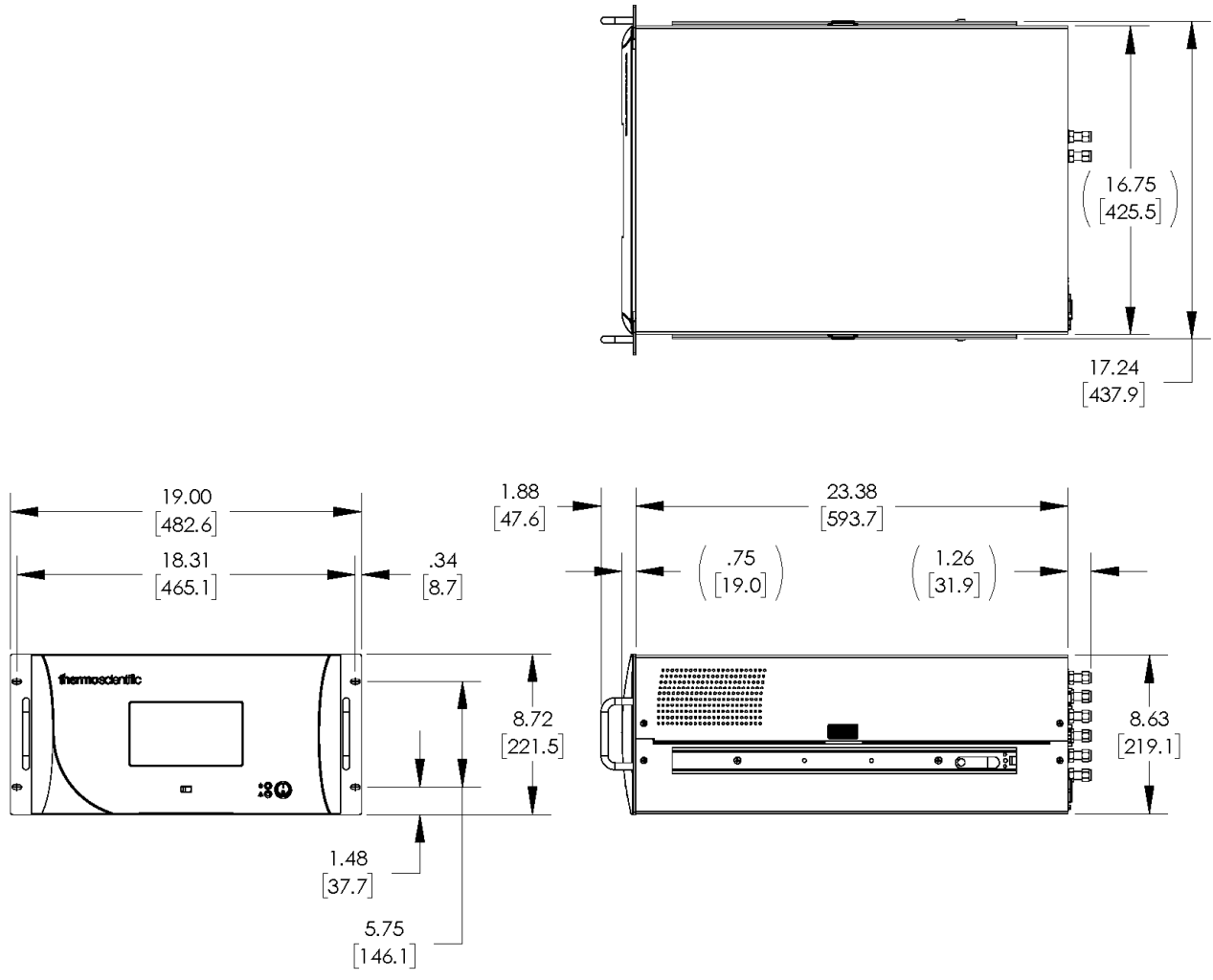
**Table 1–2.** 43iQ Optional Permeation Oven Specifications

Temperature Control	Three user selectable set points: 30, 35, 45 °C
Temperature Stability	± 0.1 °C
Warm-up Time	1 hour (permeation device can take 24 to 48 hours to stabilize)
Carrier Gas Flow	≈ 700 scc/min
Chamber size	Accepts permeation tubes up to 9 cm in total length; 1 cm in diameter
Physical Dimensions	Contained inside the 43iQ
Power Requirements	24 VDC, 50 watts (in addition to the standard 43iQ)
Weight	Approximately five pounds (in addition to standard 43iQ)

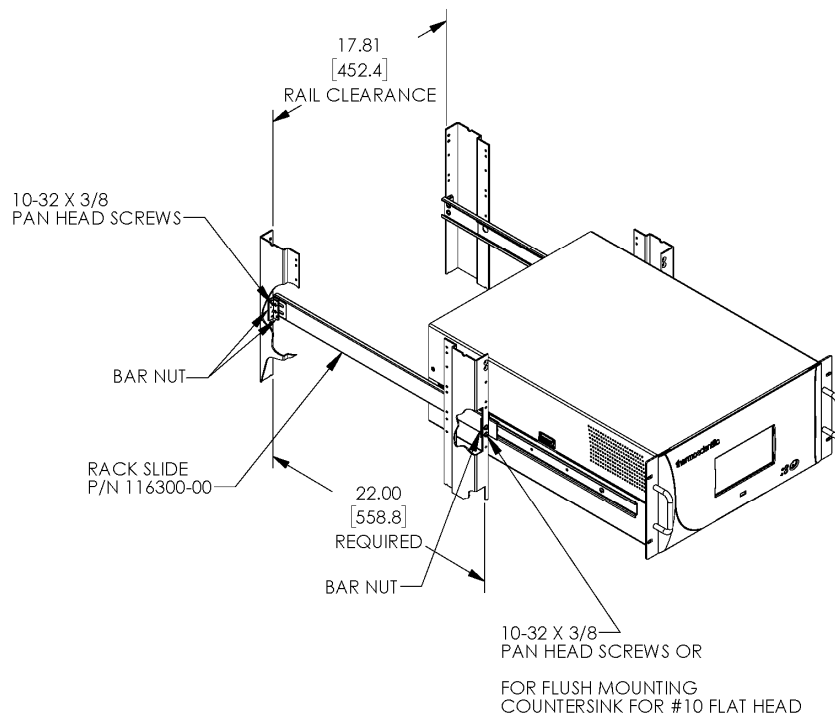
## Dimensions



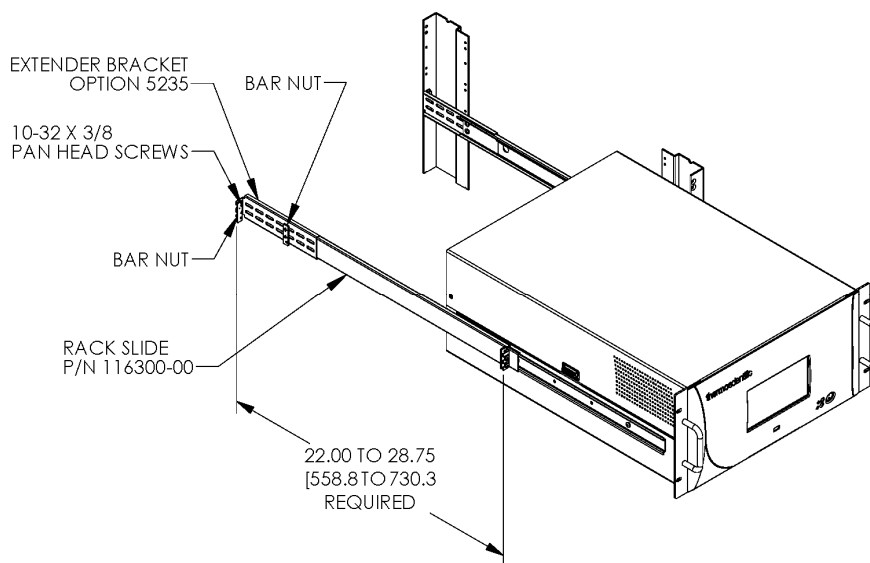
**Figure 1–4.** Bench Mount Assembly (dimensions in inches [mm])



**Figure 1-5.** Rack Mount Assembly (dimensions in inches [mm])



**Figure 1-6.** Rack Mount Requirements



**Figure 1-7.** Rack Requirements Part 2



## Chapter 2

# Installation and Setup

Installation and Setup describes how to unpack, setup, and start-up the instrument. The installation should always be followed by instrument calibration as described in the “[Calibration](#)” chapter of this manual.



**Equipment Damage** Do not attempt to lift the instrument by the cover or other external fittings. ▲

### Unpacking and Inspection

The 43iQ is shipped complete in one container. If there is obvious damage to the shipping container when you receive the instrument, notify the carrier immediately and hold for inspection. The carrier is responsible for any damage incurred during shipment.

Use the following procedure to unpack and inspect the instrument.

1. Remove the instrument from the shipping container and set it on a table or bench that allows easy access to both the front and rear.
2. Remove the cover to expose the internal components. (See “[Figure 2-1](#)” on page [2-2](#).)
3. Check for possible damage during shipment.
4. Check that all connectors and circuit boards are firmly attached.
5. Re-install the cover.
6. Remove any protective plastic material from the case exterior.

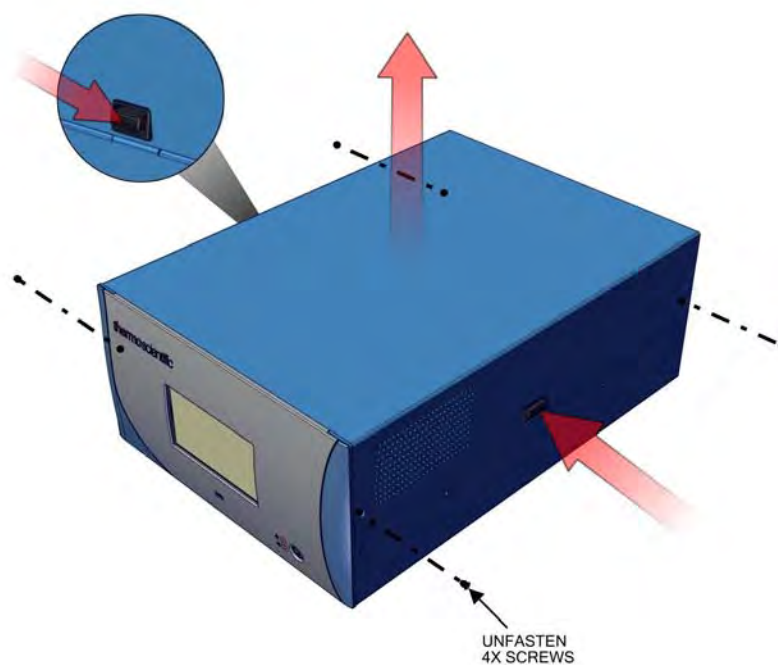
## Cover Removing and Replacing

Use the following procedure to remove and replace the cover.

Equipment required:

Phillips screwdriver, #2

1. Unfasten the four 8-32 screws securing the cover (shipping screws).
2. Press in both latches located on top cover and hold while pulling up to remove. Set upright.



**Figure 2-1.** Removing the Cover

3. To replace, align cover and drop in. Latches will automatically snap in place.

## Mounting Options

The instrument can be installed in the following configurations:

- Bench Mount
- Rack Mount

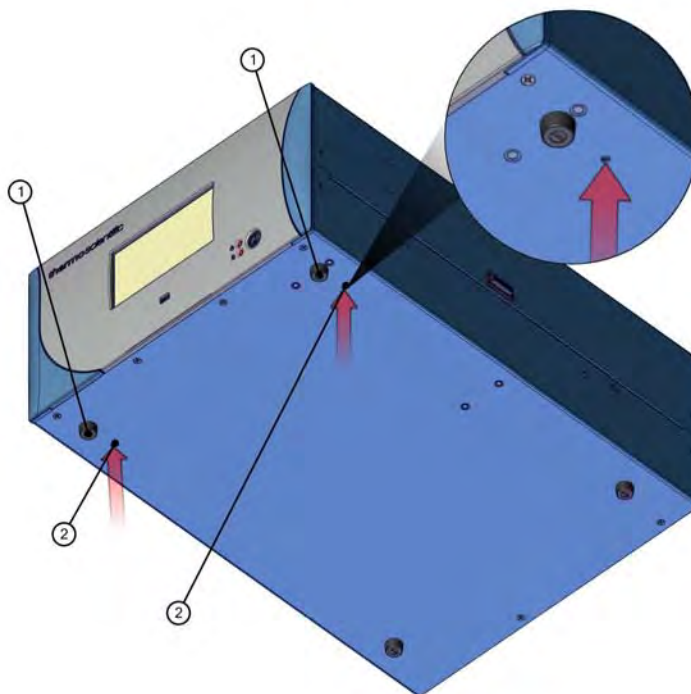
### Bench Mount

Positioned on bench, includes installing feet. See [Figure 2–2](#).

Equipment required:

Slot drive, 5/16-inch

1. Fasten feet in position 1 or 2 to fit to the desired depth.



**Figure 2–2.** Installing Feet



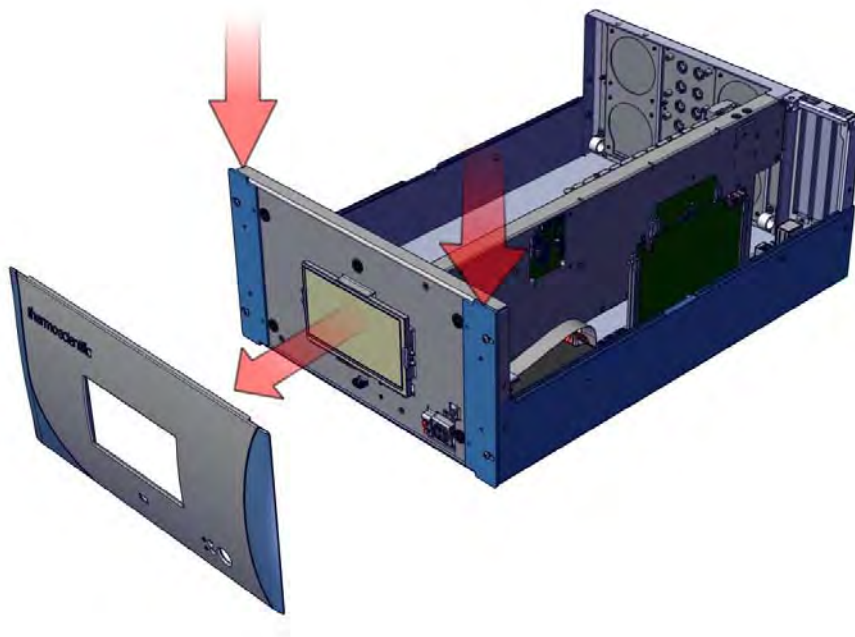
## **Rack Mount**

Mounting in a rack includes removing the front panel and installing ears and handles.

Equipment required:

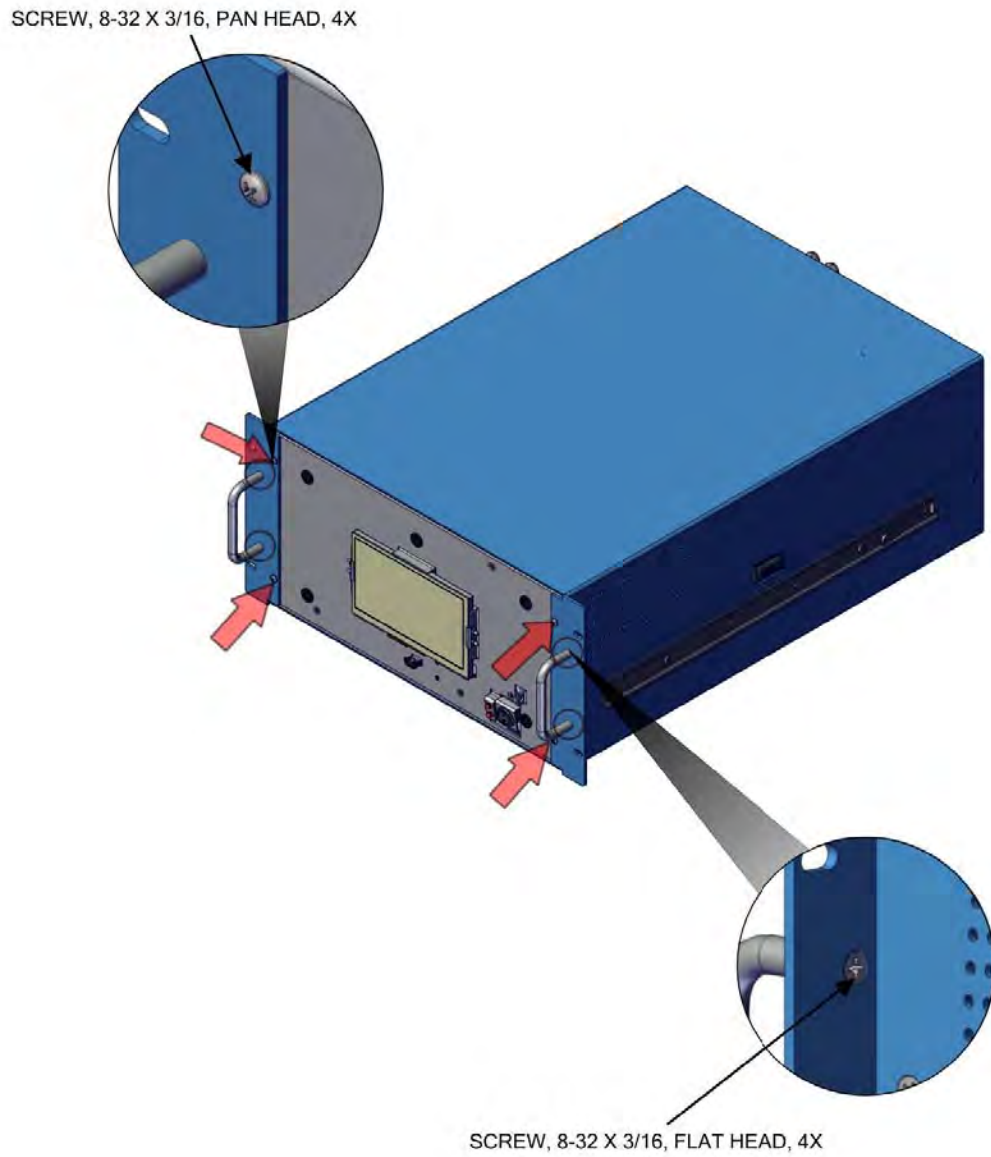
Phillips drive, #2

1. Start by gripping from the top corners of the front panel and pull outwards.



**Figure 2-3.** Removing the Front Panel

2. Unfasten the four 8-32 pan head screws.
3. Slide ears outwards.
4. Use the same four 8-32 pan head screws to secure it.
5. Install the handles with the four 8-32 flat head screws that came with the handle kit on the backside as shown.



**Figure 2-4.** Installing Ears and Handles

## Setup Procedure

Use the following procedure to setup the instrument:

1. Connect the sample line to the SAMPLE bulkhead on the rear panel (Figure 2-5). Ensure that the sample line is not contaminated by dirty, wet, or incompatible materials. All tubing should be constructed of PTFE, 316 stainless steel, borosilicate glass, or similar tubing with an OD of 1/4-inch and a minimum ID of 1/8-inch. The length of the tubing should be less than 10 feet.

**Note** Gas must be delivered to the instrument free of particulates. It may be necessary to use the PTFE particulate filter as described in “PTFE Particulate Filter” on page 9-23. ▲

**Note** If the sample may contain particulates larger than 5 microns, it should be filtered before introducing it to the instrument. Use a filter (such as PTFE) that does not interact with SO<sub>2</sub> in the sample. If a sample filter is used, all calibrations and span checks must be performed through the filter. The filter element should be replaced regularly to prevent the absorption of SO<sub>2</sub> by trapped material on the filter. ▲

**Note** Gas must be delivered to the instrument at atmospheric pressure. It may be necessary to use an atmospheric bypass plumbing arrangement as shown in Figure 2-6 if gas pressure is greater than atmospheric pressure. ▲

2. Connect the EXHAUST bulkhead to a suitable vent. The exhaust line should be 1/4-inch OD with a minimum ID of 1/8-inch. The length of the exhaust line should be less than 10 feet. Verify that there is no restriction in this line.
3. If the optional zero/span solenoid valves are installed, connect a source of SO<sub>2</sub> and HC free air to the ZERO IN bulkhead, and connect a source of SO<sub>2</sub> span gas to the SPAN bulkhead.
4. Connect a suitable recording device to the rear panel connector. For detailed information about connecting to the instrument, refer to:  
“Connecting External Devices” on page 9-1  
Communications > “Analog I/O” on page 3-80, and “Digital I/O” on page 3-81.

5. Plug the instrument into an outlet of the appropriate voltage and frequency.

**Note** If instrument is equipped with an internal permeation oven, refer to Chapter 9, “Optional Equipment” for setup instructions. ▲



The 43iQ is supplied with a three-wire grounding cord. Under no circumstances should this grounding system be defeated. ▲

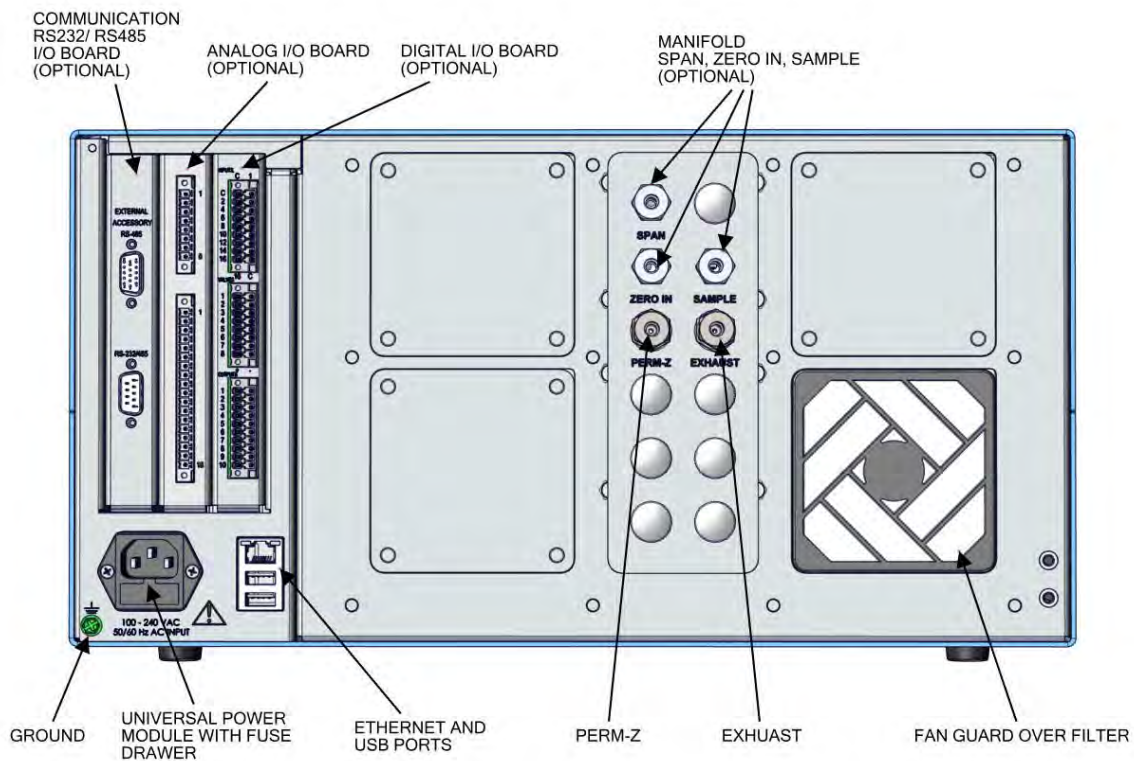


Figure 2–5. 43iQ Rear Panel

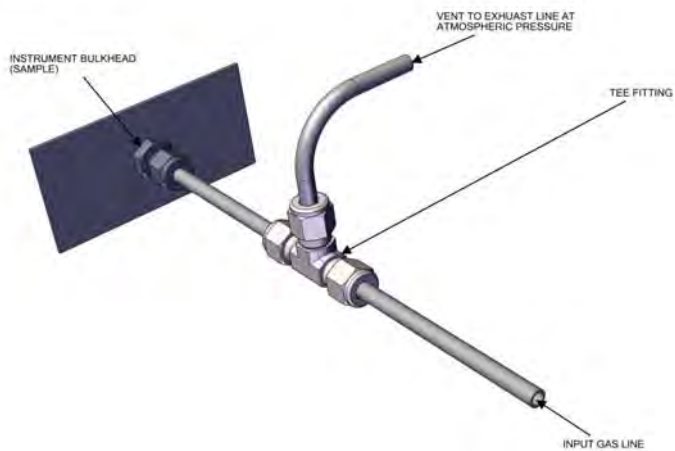
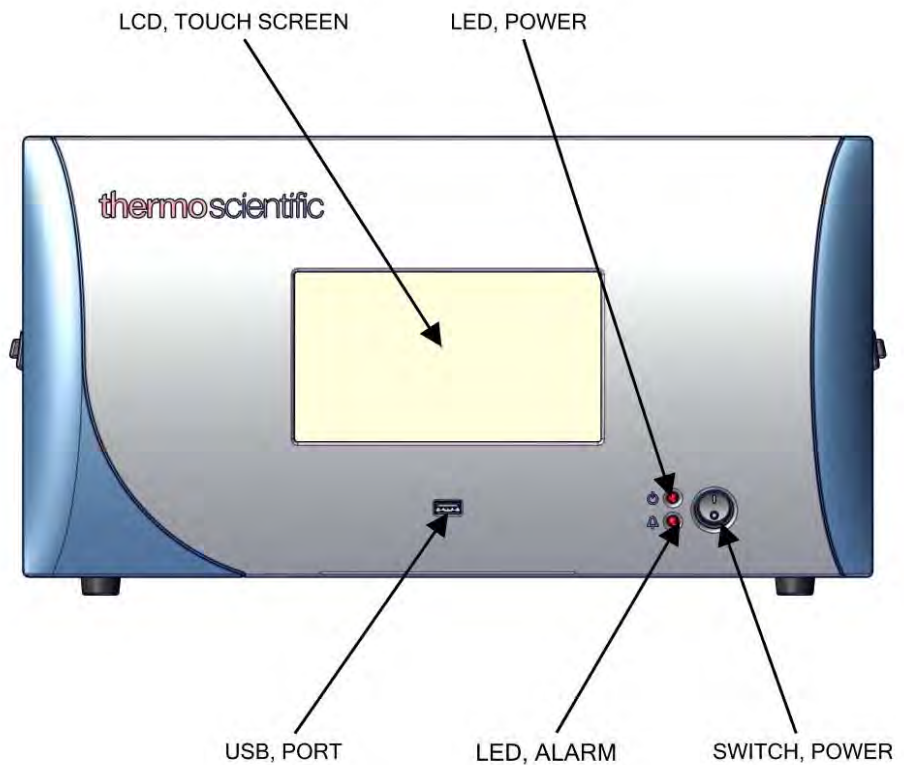


Figure 2–6. Atmospheric Dump Bypass Plumbing

## Startup

Use the following procedure when starting the instrument.

1. Turn the power ON.
2. Allow 90 minutes for the instrument to stabilize.
3. Set instrument parameters such as operating ranges and averaging times to appropriate settings. For more information about instrument parameters, see the “[Operation](#)” chapter.
4. Before beginning the actual monitoring, perform a calibration as described in the “[Calibration](#)” chapter.



**Figure 2–7.** Front Panel and Touchscreen Display

# Chapter 3

## Operation

This chapter describes the functionality of the touchscreen user interface.

### Instrument Display

The Instrument Display consists of a Title Bar, a User Interface, and a Status Bar. The Title Bar, located at the top, includes the Home button, instrument name, instrument gas mode, and Help button. The User Interface, located in the middle, is where the Home Screen and all other screens are accessed. The Home Screen has three Main Menu buttons, located on the left side, which include Calibration, Data, and Settings, while the user interface to the right of the buttons displays the chemical name, concentration value and unit. The Status Bar, located at the bottom, includes the Back button, Access Levels, Health Check, Favorites, Date and Time, and Contact Information.

#### Home Screen (single range mode)



### Home Screen (dual or auto range mode)



The Instrument Display contains the following information:

- Title Bar:
  - *Home button*: When pressed, it brings you to the Home Screen.
  - *Title Text*: Displays instrument name when in the Home Screen. Displays the chemical name, current concentration reading and unit when in all other screens. When unit is pressed, it brings you to the gas unit selection screen.
  - *Gas Mode button*: Displays current gas mode of the instrument. When pressed, brings you to the Gas Mode selection screen.
  - *Help button*: When pressed, brings you to the help screens.
- User Interface:
  - *Calibration button*: Allows the user to calibrate the instrument, setup automatic calibrations, and view calibration data.
  - *Data button*: Allows the user to view, graph, stream, and analyze data.
  - *Settings button*: Shows real-time status and alarms, also predictive diagnostics and maintenance history. Contains controls for operating the instrument, communications, and sets instrument options.
  - *Concentration*: When in single mode, displays SO<sub>2</sub> concentrations in big, bold characters, depending on operating mode. When in dual or auto mode, displays either high range or low range values based on the range setting.
- Status Bar:
  - *Back button*: When pressed, it displays the previous screen.
  - *Access Levels button*: Allows the user to set security access levels, and allows/restricts access to functionality depending on the selected access level.
  - *Health Check button*: Brings the user to the Health Check screen.
  - *Favorites button*: Allows user-selectable favorite buttons. To add to the favorites screen, user presses the desired screen button for 2 seconds. The user will be directed to the favorites screen where the user chooses the button position. To remove a favorite button from the favorites screen, press and hold button for 2 seconds.
  - *Clock*: Displays current date and time.



## Operation

### Instrument Display

- *Thermo Scientific Information button*: Shows contact information.

## Main Menus and Keypads

The Main Menu buttons, located on the Home Screen, contains three submenus. Each submenu contains related instrument settings. This chapter describes each submenu and screen in detail. Refer to the appropriate sections for more information.



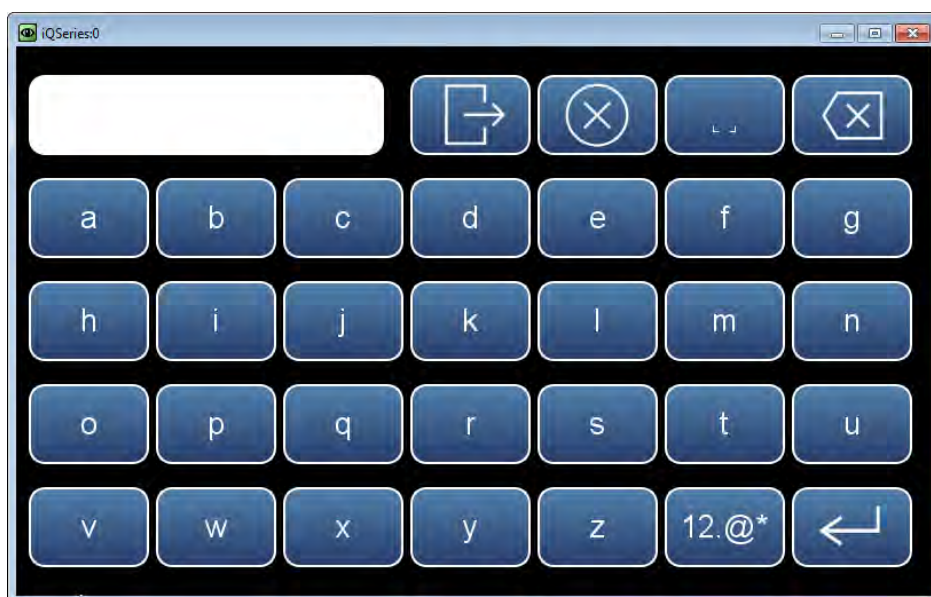
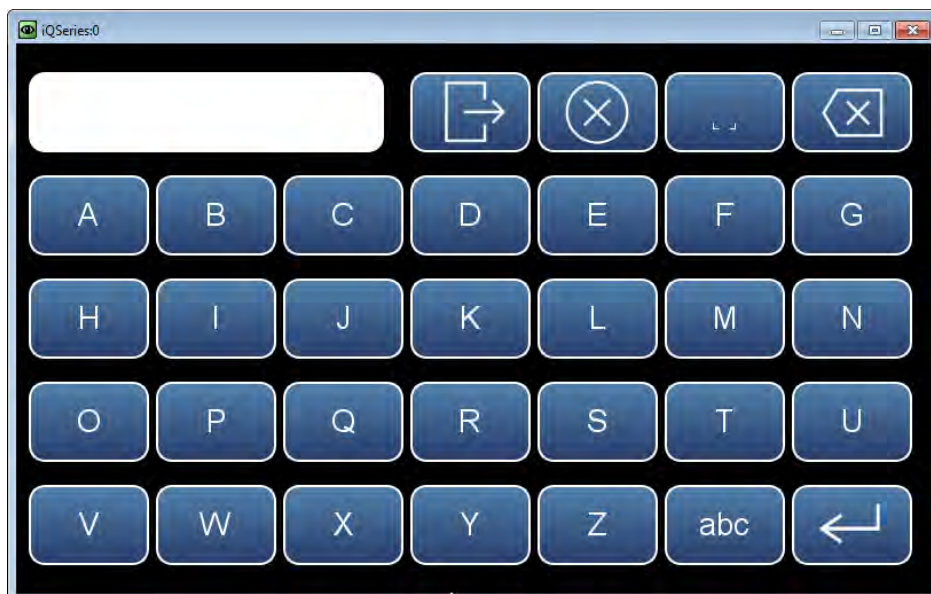
### **Numeric Keypad**

User enters a value into the box using the number keypad. When the user needs to change a value, such as for flow rates, temperatures or pressures, the keypad screen will automatically display. Initially, the box above the keypad will display the current value. Enter a new value using the keypad, and then select the **Enter** button to set the new value or press the **Cancel** button to exit the keypad screen and return to the previous screen without saving the value.

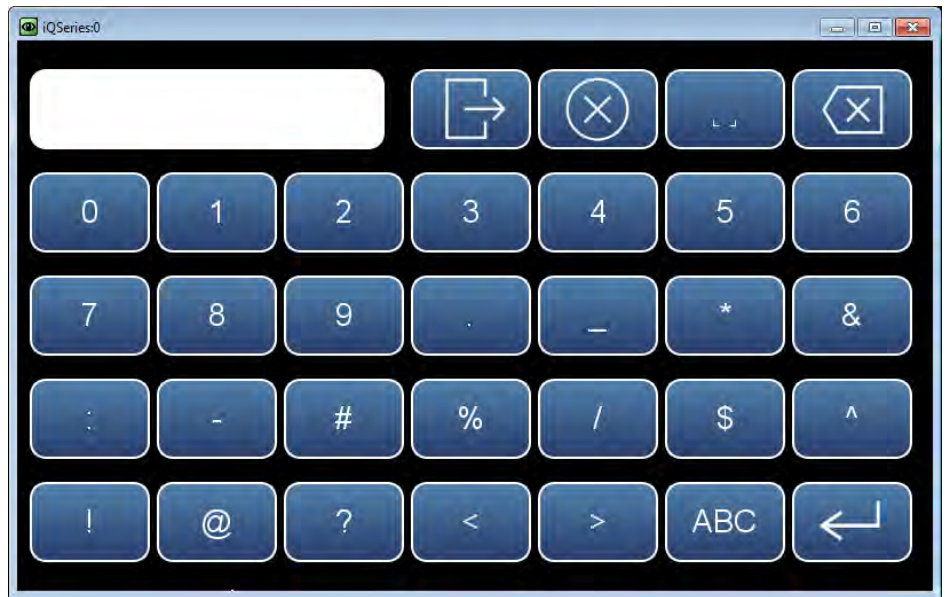


## Alphanumeric Keypad

User enters a value into the box using the keypad. When the user needs to change an alphanumeric value, this keypad will automatically display. Initially, the box above the keypad will display the current value. Enter a new value using the keypad, and then select the **Enter** button to set the new value or press the **Cancel** button to exit the keypad screen and return to the previous screen without saving the value. The alphanumeric keypad is only available when the user needs to enter alphabet characters.



**Operation**  
Instrument Display

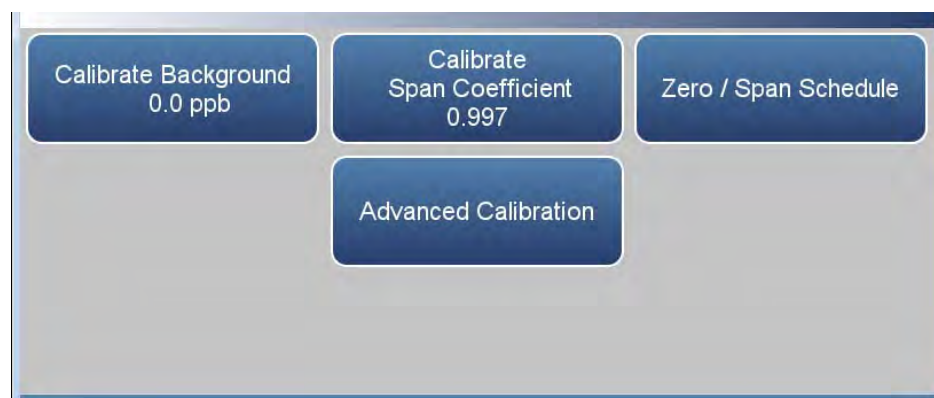


## Calibration

The Calibration screen allows the user to calibrate the system, setup automatic calibrations, and view calibration data. See Chapter 4 “[Calibration](#)” for further instructions on how to run a calibration.

The following screens show the calibration screens in single range mode and dual or auto range mode. The dual and auto range modes have two SO<sub>2</sub> span factors (high and low). This allows each range to be calibrated separately. This is necessary if the two ranges used are not close to one another. For example, a low SO<sub>2</sub> range of .5 ppm and a high SO<sub>2</sub> range of 10 ppm. For more information about range modes, see “[Range Mode Selection](#)” on page 3-65.

### Home Screen>Calibration (single range mode)



### Home Screen>Calibration (dual or auto range mode)



The Calibration screen contains the following information:

- *Calibrate Background:* Sets the SO<sub>2</sub> reading to zero.
- *Calibrate Span Coefficient:* Sets the span coefficient when in single range mode.

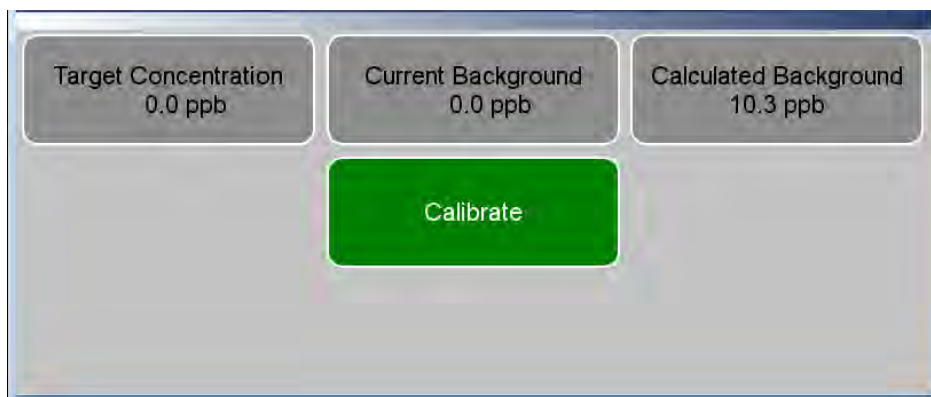
- *Calibrate High Range Span Coefficient:* Sets the high range span coefficient when in dual or auto range mode.
- *Calibrate Low Range Span Coefficient:* Sets the low range span coefficient when in dual or auto range mode.
- *Zero/Span Schedule:* Programs the instrument to perform fully automated zero and span checks or adjustments.
- *Advanced Calibration:* Calibrates the instrument using manual zero/span calibration and provides calibration history.

## Calibrate Background

The Calibrate Background screen is used to calibrate the instrument zero background. Before making an adjustment, be sure the analyzer samples zero air for at least 5 minutes.

It is important to note the averaging time when calibrating. The longer the averaging time the more precise the calibration results. To achieve maximum precision, allow the instrument to stabilize each time input gas is changed and set the averaging time to 300-second averaging.

### Home Screen>Calibration>Calibrate Background



The Calibrate Background screen contains the following information:

- *Target Concentration:* Read only. Displays what the concentration value will become when the calibrate button is pressed.
- *Current Background:* Read only. Displays what the current user-set background is.
- *Calculated Background:* Read only. Displays what the current user-set background will become when the calibrate button is pressed.
- *Calibrate:* When pressed, updates the background value, setting the displayed concentration to zero.



## Calibrate Span Coefficient

The Calibrate Span Coefficient screen is used to enter the span concentration and calibrate the SO<sub>2</sub> span coefficient. The SO<sub>2</sub> span coefficient is calculated, stored, and used to correct the current reading.

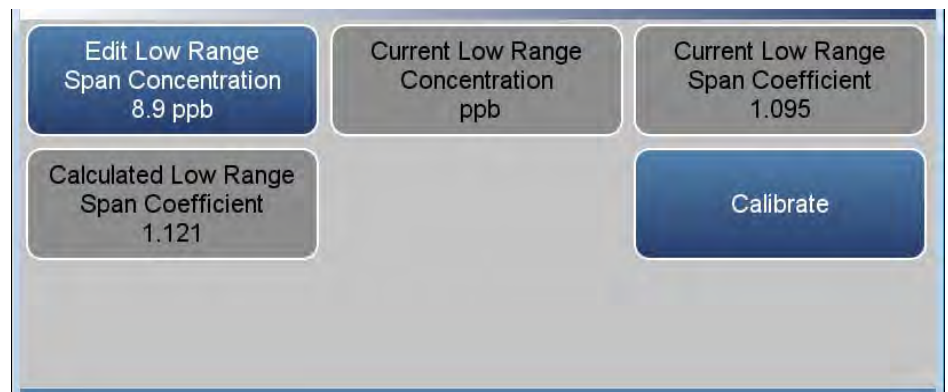
The following screens are shown in single range mode and dual or auto range mode. In dual or auto range modes, “High” or “Low” is displayed to indicate the calibration of the high or low coefficient. The Calibrate High Range Span Coefficient and Calibrate Low Range Span Coefficient screens function the same way.

It is important to note the averaging time when calibrating. The longer the averaging time the more precise the calibration results. To achieve maximum precision, allow the instrument to stabilize each time input gas is changed and set the averaging time to 300-second averaging.

### Home Screen>Calibration>Calibrate Span Coefficient (single range mode)



### Home Screen>Calibration>Calibrate Span Coefficient (dual or auto range mode)



The Calibrate Span Coefficient screen contains the following information:

- *Edit Span Concentration*: User enters the span gas concentration when in single range mode.
- *Edit High Range Span Concentration*: User enters the high range span concentration when in dual or auto range mode.
- *Edit Low Range Span Concentration*: User enters the low range span concentration when in dual or auto range mode.
- *Current High Range Concentration*: Read only. Current high range concentration reading when in dual or auto range mode.
- *Current Low Range Concentration*: Read only. Current low concentration reading when in dual or auto range mode.
- *Current Span Coefficient*: Read only. Displays the current instrument span coefficient.
- *Current High Range Span Coefficient*: Read only. Displays the current instrument high range span coefficient.
- *Current Low Range Span Coefficient*: Read only. Displays the current instrument low range span coefficient.
- *Calculated Span Coefficient*: Read only. After the “Edit Span Concentration” value is entered, the new calculated span coefficient is displayed.
- *Calculated High Range Span Coefficient*: Read only. After the “Edit High Range Span Concentration” value is entered, the new calculated high range span coefficient is displayed.
- *Calculated Low Range Span Coefficient*: Read only. After the “Edit Low Range Span Concentration” value is entered, the new calculated low range span coefficient is displayed.
- *Calibrate*: When pressed, updates the coefficient and the concentration should match the span concentration.

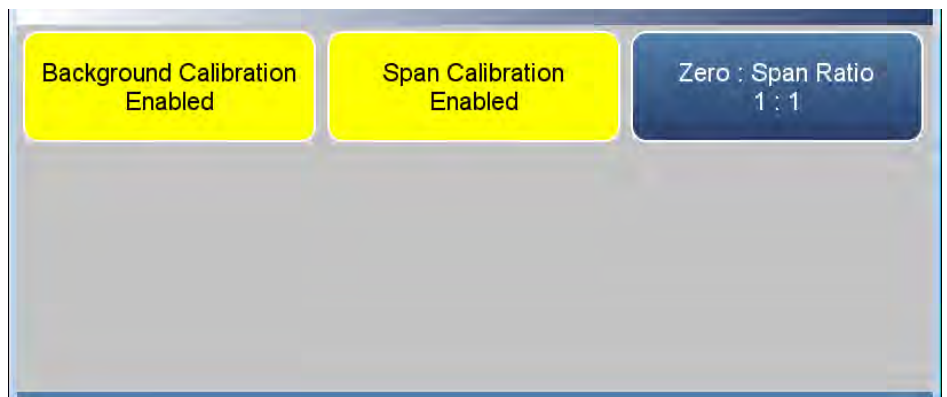
## Zero/Span Schedule

The Zero/Span Schedule is used to program the instrument to perform fully automated zero and span checks or adjustments.

### Home Screen>Calibration>Zero/Span Schedule



### Home Screen>Calibration>Zero/Span Schedule>More



The Zero/Span Schedule contains the following information:

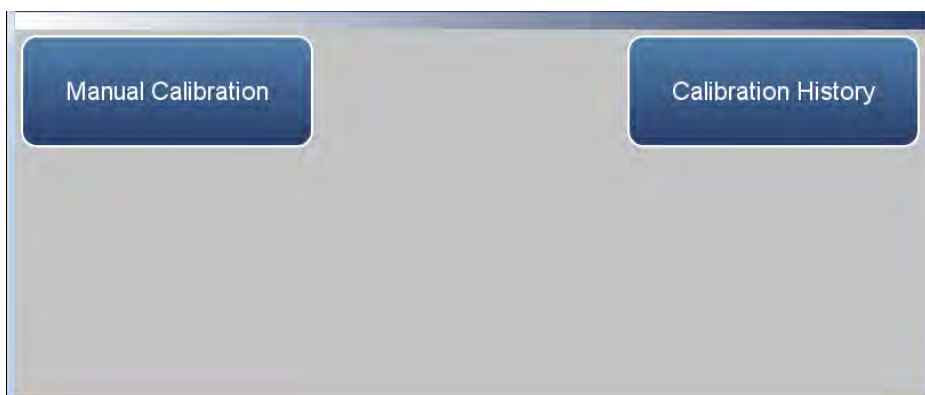
- *Zero/Span Schedule:* Toggles zero/span schedule Enabled or Disabled.
- *Next Time:* Allows the user to view and set the initial date and time (24-hour format) of the zero/span schedule.
- *Period:* Defines the period or interval between zero/span checks or calibrations. If period = 0, the schedule runs continuously.
- *Zero Duration:* Sets how long zero air is sampled by the instrument.
- *Span Duration:* Sets how long span gas is sampled by the instrument.
- *Purge Duration:* Sets how long the purge period will be at the end of the schedule.

- *Total Duration*: Read only. Displays the total time duration of all scheduled events.
- *Schedule Averaging Time*: Allows the user to adjust the zero/span schedule averaging time. This averaging time only affects the zero/span schedule.
- *Background Calibration*: Toggles Enabled/Disabled. If enabled, background value is calibrated. If disabled, schedule runs a background check only and background value is not updated.
- *Span Calibration*: Toggles Enabled/Disabled. If enabled, span coefficient is calibrated. If disabled, schedule runs a calibration check only and span coefficient is not updated.
- *Zero : Span Ratio*: Allows the user to perform more scheduled background calibration checks to span calibration checks. Default is 1 and therefore reads 1:1. (This means that each time the schedule is run, both the zero duration and span duration occurs.) The zero/span ratio is allowable between 1 to 99. If 99 is chosen, the schedule should only perform the Span on the 99th iteration.

## Advanced Calibration

The Advanced Calibration screen provides a manual way to calibrate the instrument and view the calibration history. See Chapter 4 “Calibration” for further instructions on how to run a calibration.

**Home Screen>Calibration>Advanced Calibration**



The Advanced screen contains the following information:

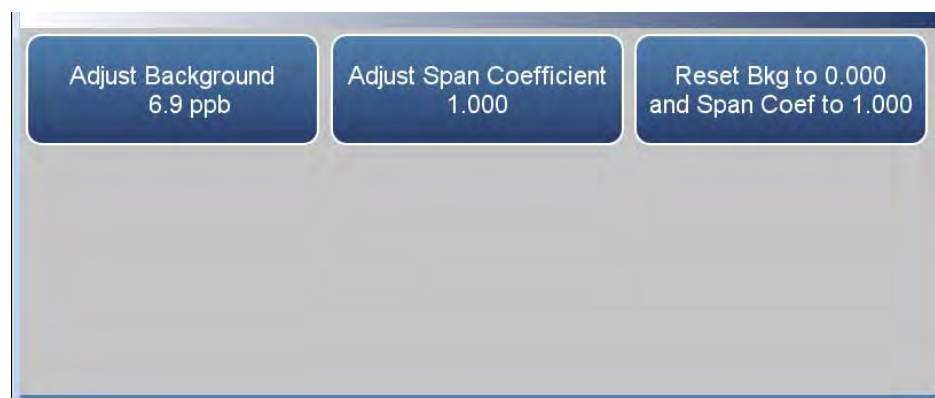
- *Manual Calibration:* The user manually calibrates the background or span coefficient.
- *Calibration History:* Lists all calibrations performed and calibration checks.

## Manual Calibration

The Manual Calibration screen adjusts the zero background or span coefficient based on a user entered value. See Chapter 4, “[Calibration](#)” for instructions on how to run a Manual Calibration.

The following screens show the manual calibration screens in single range mode and dual or auto range mode. In dual or auto range modes, “High Range” or “Low Range” buttons are displayed to indicate the calibration of the high or low coefficient.

### Home Screen>Calibration>Advanced Calibration>Manual Calibration (single range mode)



### Home Screen>Calibration>Advanced Calibration>Manual Calibration (dual or auto range mode)



The Manual Calibration screen contains the following information:

- *Adjust Background:* Allows the user to manually adjust the zero background.
- *Adjust Span Coefficient:* Allows the user to manually adjust the span coefficient when in single range mode.

**Operation**  
Calibration

- *Adjust High Range Span Coefficient:* Allows the user to manually adjust the high range span coefficient when in dual or auto range mode.
- *Adjust Low Range Span Coefficient:* Allows the user to manually adjust the low range span coefficient when in dual or auto range mode.
- *Reset Background to 0.000 and Span Coefficient to 1.000:* Resets all backgrounds and coefficients.

## Adjust Background

The Adjust Background screen is used to manually adjust the zero background.

**Home Screen>Calibration>Advanced Calibration>Manual Calibration>Adjust Background**



The Adjust Background screen contains the following information:

- *Adjust Background:* User manually adjusts zero background.
- *Adjusted Concentration:* Read only. Shows adjusted concentration based on adjusted zero background.
- *Calibrate:* Calibrates zero background by saving the newly adjusted zero background value.

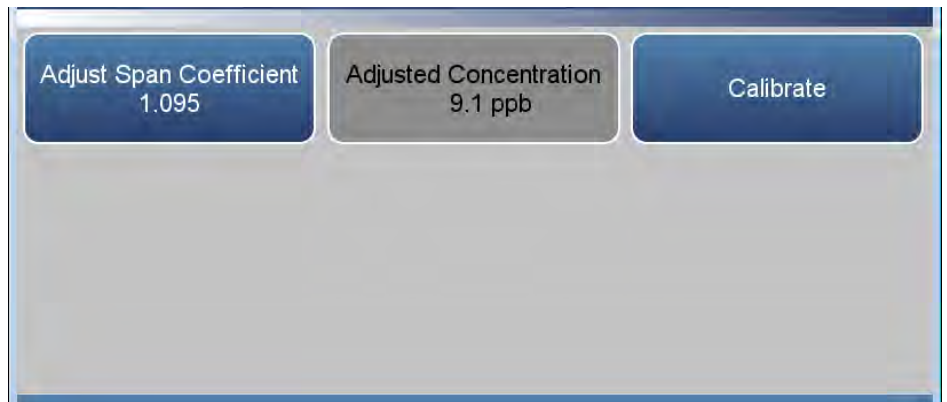


## Adjust Span Coefficient

The Adjust Span Coefficient screen is used to manually adjust the span coefficient.

The following screen is shown in single range mode and dual or auto range mode. In dual or auto range modes, “High Range” or “Low Range” is displayed to indicate the calibration of the high or low coefficient. The Adjust High Range Span Coefficient and Adjust Low Range Span Coefficient screens function the same way.

### Home Screen>Calibration>Advanced>Manual Calibration>Adjust Span Coefficient (single range mode)



### Home Screen>Calibration>Advanced Calibration>Manual Calibration>Adjust High Range Span Coefficient (dual or auto range mode)



The Adjust Span Coefficient screen contains the following information:

- *Adjust Span Coefficient*: User manually adjusts span coefficient when in single range mode.
- *Adjusted Concentration*: Read only. Shows adjusted concentration based on adjusted span coefficient when in single range mode.

- *Adjust High Range Span Coefficient:* User manually adjusts high range span coefficient when in dual or auto range mode.
- *Adjusted High Range Concentration:* Read only. Shows adjusted high range concentration based on adjusted high range span coefficient when in dual or auto range mode.
- *Adjust Low Range Span Coefficient:* User manually adjusts low range span coefficient when in dual or auto range mode.
- *Adjusted Low Range Concentration:* Read only. Shows adjusted low range concentration based on adjusted low range span coefficient when in dual or auto range mode.
- *Calibrate:* Calibrates span coefficient by saving the newly adjusted span coefficient.


## Calibration History

The Calibration History screen shows the log of calibrations and calibration checks performed.

Use the ▲ and ▼ buttons to move up and down and the ◀ and ▶ buttons to move left and right.

**Home Screen>Calibration>Advanced Calibration>Calibration History**

**Note** Pressing the Calibration History button responds with Retrieving calibration log data, it may take a few seconds... ▲



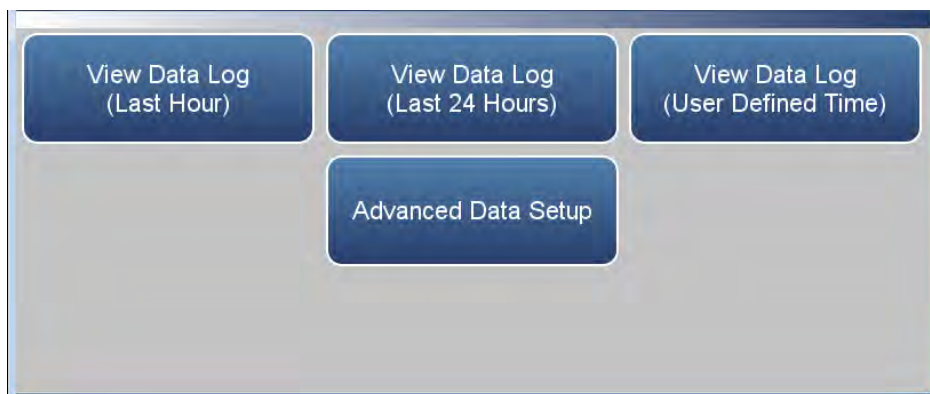
Time Stamp	Event	Result	Target	Units	Average Time
08/08/2017_14:43:41	Low Span Cal	0.998817	13.9175	ppb	300
08/08/2017_14:41:28	Reset Def Coefs	n/a	n/a	ppb	10
08/08/2017_14:41:11	Low Span Cal	0.670144	9	ppb	10
08/08/2017_14:32:26	Low Span Cal	0.998817	13.9175	ppb	300
08/08/2017_14:27:38	Low Span Cal	0.998817	13.9175	ppb	300
08/08/2017_14:24:15	Low Span Cal	0.998817	13.9175	ppb	300
08/08/2017_14:23:57	High Span Cal	0.998817	13.9175	ppb	300
08/08/2017_13:23:52	Low Span Cal	0.678192	9.73656	ppb	10
08/07/2017_09:19:34	Low Span Cal	0.735263	10	ppb	10
08/07/2017_09:19:06	Low Span Cal	1.10179	14.7018	ppb	10

The Calibration History screen contains the following information:

- *Time Stamp*: Time of calibration or calibration check.
- *Event*: Lists the type of calibration event.
- *Result*: Concentration result.
- *Target*: Concentration setpoint value.
- *Units*: Displays units for each item.
- *Average Time*: Averaging time used during the calibration or calibration check.

**Data** The Data screen is used to view recorded concentrations and instrument data. Users can view both tabular data and graphed data.

**Home Screen>Data**



The Data screen contains the following information:

- *View Data Log (Last Hour)*: User views last hour of historical data. Table shows most recent data on top.
- *View Data Log (Last 24 Hours)*: User views 24-hour of historical data. Table shows most recent data on top.
- *View Data Log (User Defined Time)*: User selects the start and end time for viewing the data. Table shows most recent data on top.
- *Advanced Data Setup*: Allows the user to set up the parameters of how the data is stored.

## View Data Log (Last Hour)

The View Data Log (Last Hour) screen allows the user to view the last hour worth of data in tabular and/or graphical form.

Use the ▲ and ▼ buttons to move up and down and the ◀ and ▶ buttons to move left and right.

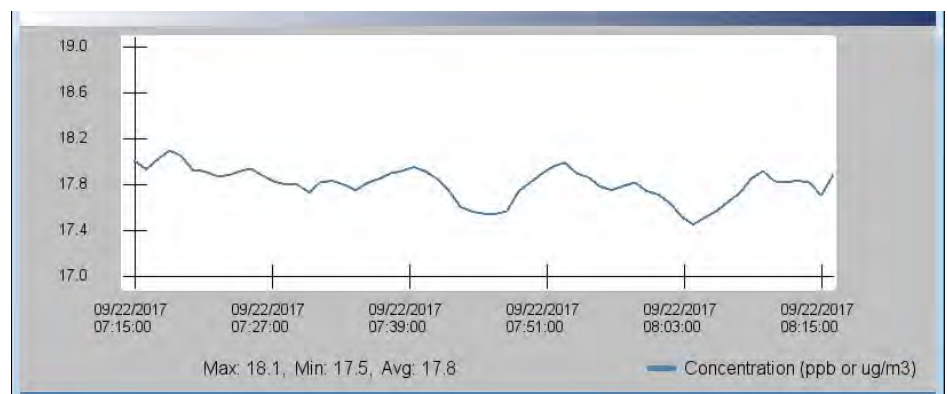
**Home Screen>Data>View Data Log (Last Hour)**

**Note** Pressing the View Data Log (Last Hour) responds with Retrieving user log data, it may take a few seconds... ▲

Time Stamp	Concentration (ppb or ug/m3)	Bench Pressure (mmHg)	Instrument Temperature (degC)	PMT High Voltage (Volts)	Flash Voltage
	Graph	Graph	Graph	Graph	Graph
09/22/2017 08:15:00	17.8845	0	0	0	0
09/22/2017 08:14:00	17.7086	0	0	0	0
09/22/2017 08:13:00	17.8215	0	0	0	0
09/22/2017 08:12:00	17.8394	0	0	0	0
09/22/2017 08:11:00	17.8261	0	0	0	0
09/22/2017 08:10:00	17.8338	0	0	0	0
09/22/2017 08:09:00	17.9224	0	0	0	0
09/22/2017 08:08:00	17.8584	0	0	0	0

The View Data Log (Last Hour) screen contains the following options:

- *Graph*: Displays data graph for the column selected. The graph time axis is defined by the data set in the table.



## View Data Log (Last 24 Hours)

The View Data Log (Last 24 Hours) screen allows the user to instantly view the last 24 hours worth of data in real time.

Use the ▲ and ▼ buttons to move up and down and the ◀ and ▶ buttons to move left and right.

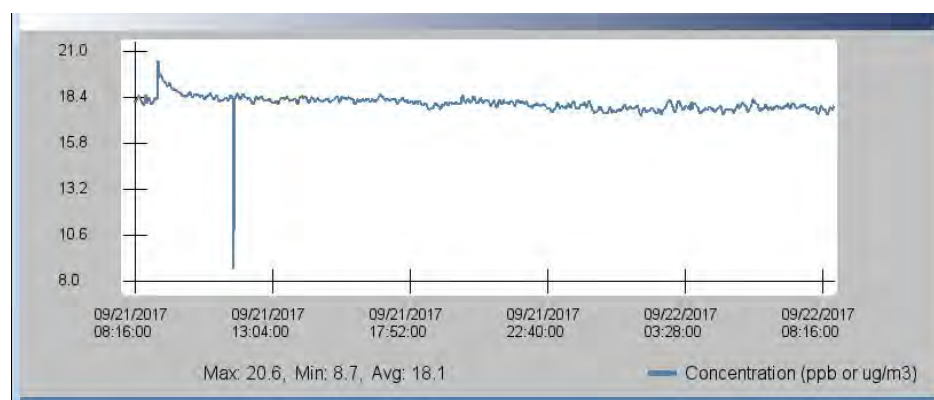
**Home Screen>Data>View Data Log (Last 24 Hours)**

**Note** Pressing the View Data Log (Last 24 Hours) responds with Retrieving user log data, it may take a few seconds... ▲

Time Stamp	Concentration (ppb or ug/m3)	Bench Pressure (mmHg)	Instrument Temperature (degC)	PMT High Voltage (Volts)	Flashe Voltage
	Graph	Graph	Graph	Graph	Graph
09/22/2017 08:16:00	17.9427	0	0	0	0
09/22/2017 08:15:00	17.8845	0	0	0	0
09/22/2017 08:14:00	17.7086	0	0	0	0
09/22/2017 08:13:00	17.8215	0	0	0	0
09/22/2017 08:12:00	17.8394	0	0	0	0
09/22/2017 08:11:00	17.8261	0	0	0	0
09/22/2017 08:10:00	17.8338	0	0	0	0
09/22/2017 08:09:00	17.9224	0	0	0	0

The View Data Log (Last 24 Hours) screen contains the following options:

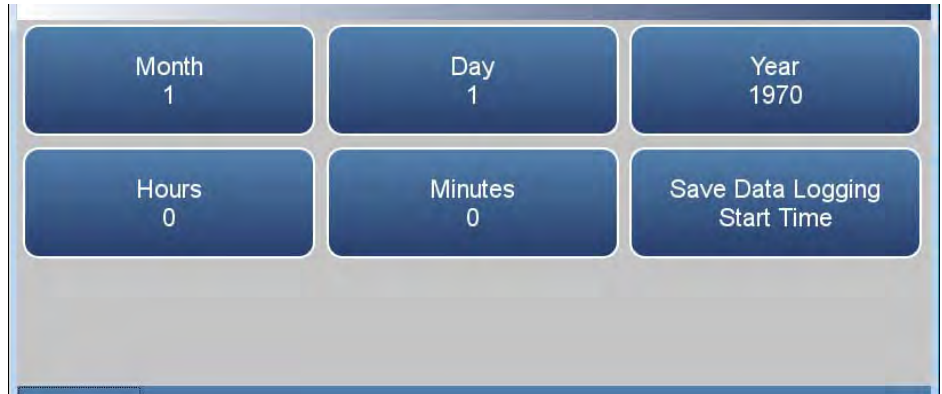
- *Graph*: Displays data graph for the column selected. The graph time axis is defined by the data set in the table.



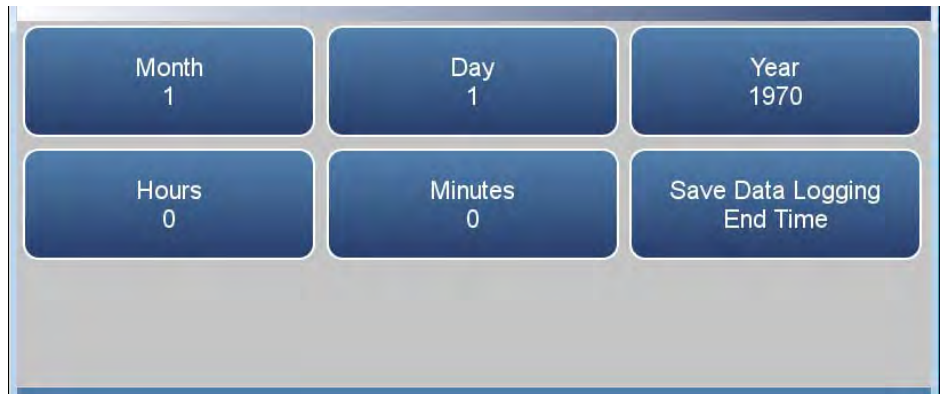
## View Data Log (User Defined Time)

The View Data (User Defined Time) screen is used to specify the start and end time for viewing the data logging table.

**Home Screen>Data>View Data Log (User Defined Time)**



**Home Screen>Data>View Data Log (User Defined Time)>Save Data Logging Start Time**



The View Data Log (User Defined Time) screen contains the following information:

- *Month*: Sets month of data logging start time.
- *Day*: Sets day of data logging start time.
- *Year*: Sets year of data logging start time.
- *Hours*: Sets hours of data logging start time.
- *Minutes*: Sets minutes of data logging start time.
- *Save Data Logging Start Time*: Pressing this button saves the start time and follows directly to the end time selection for the data logging screen.

The View Data Log (User Defined Time) End Time screen contains the following information:

- *Month*: Sets month of data logging end time.
- *Day*: Sets day of data logging end time.
- *Year*: Sets year of data logging end time.
- *Hours*: Sets hour of data logging end time.
- *Minutes*: Sets minute of data logging end time.
- *Save Data Logging End Time*: Pressing the Save Data Logging End Time button saves the end time and follows directly to the data logging table.

**Note** End time should not be greater than 1 year from start time . ▲

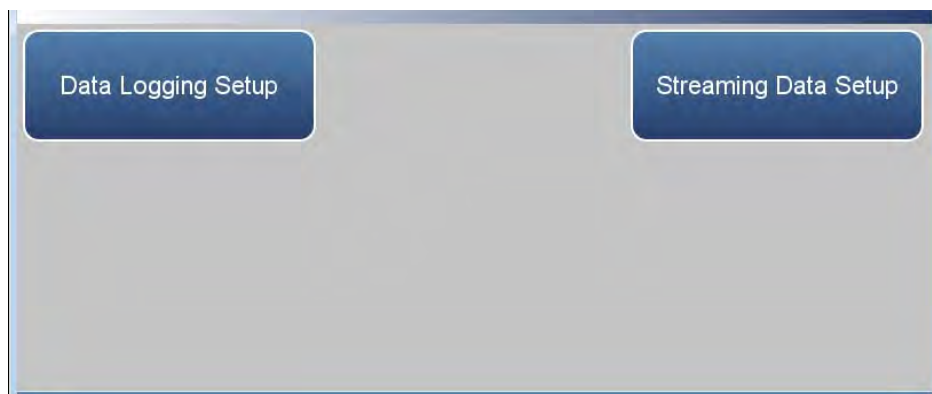
**Note** The datalogging table is limited to 10,000 points. ▲



## Advanced Data Setup

The Advanced Data Setup screen allows the user to select variables and set up parameters for data logging and streaming data.

**Home Screen>Data>Advanced Data Setup**



The Advanced Data Setup screen contains the following information:

- *Data Logging Setup*: User selects the parameters for collecting logged data.
- *Streaming Data Setup*: User selects the parameters for streaming data to a computer in real time.

## Data Logging Setup

The Data Logging Setup screen allows the user to select data to be stored and how it is stored.

### Home Screen>Data>Advanced>Data Logging Setup



The Data Logging Setup screen contains the following information:

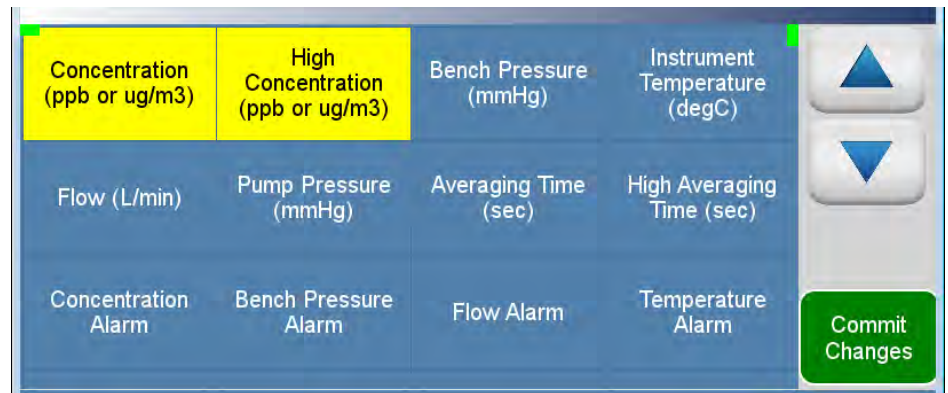
- *Select Data Logging Variables:* User selects instrument variables to log. See “Table 3–1” for data logging variables list.
- *Period:* User selects how often data is collected by setting the duration between logged data values.
- *Data Treatment:* Toggles between Average, Current, Minimum and Maximum. When set to average, the average value during the period will be recorded. When set to current, the latest data will be recorded. When set to minimum or maximum, the minimum or maximum value during the period will be recorded.
- *Erase Data Log Records:* Allows the user to erase all values in the data log and updates the data logging table.

### Select Data Logging Variables

The Select Data Logging Variables screen allows the user to select which variables to store. Note: The Data logging and Streaming variable lists are **exclusive** from each other but contain the same variable selections.

Use the ▲ and ▼ buttons to scroll through the variables. Select the variables to log by pressing the corresponding cells. Next, press the **Commit Changes** button to save selections. Yellow buttons indicate that the variable is selected. More than one can be chosen.

#### Home Screen>Data>Advanced>Data Logging Setup>Select Data Logging Variables



The following table contains the variables that can be selected for data logging:

**Table 3–1.** Data Logging Variables

Description
Concentration (ppb or µg/m3)
High Concentration (ppb or µg/m3)
Bench Pressure (mmHg)
Instrument Temperature (degC)
Flow (L/min)
Pump Pressure (mmHg)
Averaging Time (sec)
High Averaging Time (sec)
Concentration Alarm
Bench Pressure Alarm
Flow Alarm
Temperature Alarm

Auto Zero Cal/Check Alarm
Auto Span Cal/Check Alarm
Flow Pressure Module Alarms
Concentration Alarms
Gas Mode
General Alarm
Alerts
Instrument Error
Low Dynamic Filter Status
High Dynamic Filter Status
Dilution Ratio
Bench Alarm Count
Bench Temperature Alarm
Bench Temperature (degC)
Flasher High Voltage (Volts)
PMT High Voltage (Volts)
External Alarm 1
External Alarm 2
External Alarm 3
Analog Input 1
Analog Input 2
Analog Input 3
Analog Input 4
Analog Alarms
PSB Alarms
Perm Oven Body Temp (deg C)
Perm Oven Gas Temp (deg C)

## Streaming Data Setup

The Streaming Data Setup screen allows the user to stream data to a computer.

**Home Screen>Data>Advanced>Streaming Data Setup**



The Streaming Data Setup screen contains the following information:

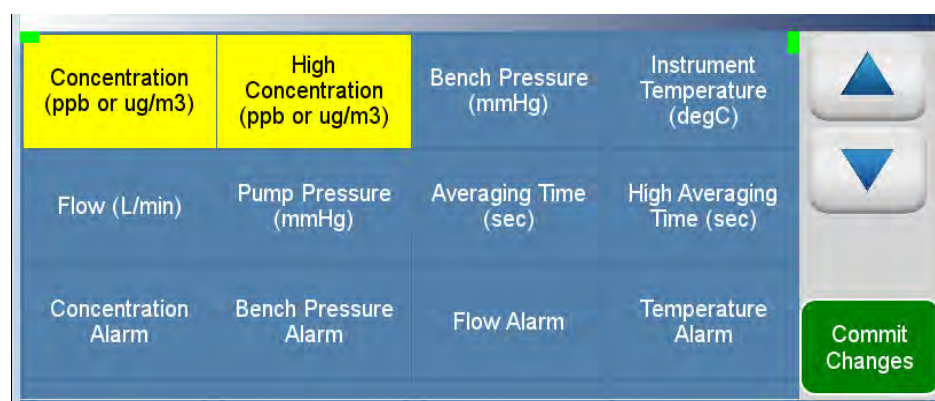
- *Select Streaming Variables*: User selects which variables to stream. See [Table 3–2](#) for streaming variable list.
- *Period*: Sets the time between streamed data.
- *Show Labels*: Toggles on/off. When on, shows variable labels to the left of the variable values.
- *Show Timestamp*: Toggles on/off. When on, shows timestamp at the beginning of each row of data.

### Select Streaming Variables

The Select Streaming Variables screen allows the user to select which variables to track. Note: The Data logging and Streaming variable lists are **exclusive** from each other but contain the same variable selections.

Use the ▲ and ▼ buttons to scroll through the variables. Select the variables to log by pressing the corresponding cells. Next, press the **Commit Changes** button to save selections. Yellow buttons indicate that the variable is selected. More than one can be chosen.

#### Home Screen>Data>Advanced>Streaming Data Setup>Select Streaming Variables



The following table contains the variables that can be selected for streaming data:

**Table 3–2.** Streaming Data Variables

Description
Concentration (ppb or µg/m3)
High Concentration (ppb or µg/m3)
Bench Pressure (mmHg)
Instrument Temperature (degC)
Flow (L/min)
Pump Pressure (mmHg)
Averaging Time (sec)
High Averaging Time (sec)
Concentration Alarm
Bench Pressure Alarm
Flow Alarm

<b>Description</b>
Temperature Alarm
Auto Zero Cal/Check Alarm
Auto Span Cal/Check Alarm
Flow Pressure Module Alarms
Concentration Alarms
Gas Mode
General Alarm
Alerts
Instrument Error
Low Dynamic Filter Status
High Dynamic Filter Status
Dilution Ratio
Bench Alarm Count
Bench Temperature Alarm
Bench Temperature (degC)
Flasher High Voltage (Volts)
PMT High Voltage (Volts)
External Alarm 1
External Alarm 2
External Alarm 3
Analog Input 1
Analog Input 2
Analog Input 3
Analog Input 4
Analog Alarms
PSB Alarms
Perm Oven Body Temp (deg C)
Perm Oven Gas Temp (deg C)

## Settings

The Settings screen allows the user to view the status and alarms, set up user preferences, communicate with outside devices and computers, download files to USB, and sets security protocol.

### Home Screen>Settings




The Settings screen contains the following information:


- *Health Check:* View instrument status and alarms, predictive diagnostics, preventive maintenance alerts, maintenance history, email health check report files, and contact Thermo Fisher Scientific technical support.
- *Measurement Settings:* Allows the user to setup user preferences as related to the concentration readings.
- *Communications:* Allows the user to communicate with outside devices.
- *Instrument Setting:* Allows the user to setup alarm setpoints and user preferences.
- *Configuration:* User selects which options to enable.
- *Security Access Levels:* User selects security protocol. User can also change security passwords.
- *USB Drive:* User can update instrument firmware, download data, and change USB password.
- *User Contact Information:* User sets up their contact information.
- *Update Bootloader:* Used to update bootloader when an update to the bootloader is available.



## Health Check

The Health Check screen is used for viewing instrument status and alarms, predictive diagnostics, preventive maintenance schedules, maintenance history, emailing files describing the health/status of the instrument, and viewing the instrument's firmware version.

**Note**  This symbol denotes there is an active alarm in the module. ▲

**Note**  This symbol denotes there is an active maintenance alarm or condition in the module. ▲

### Home Screen>Settings>Health Check




The Health Check screen contains the following information:

- *Status and Alarms:* Allows the user to view the status and alarm menus. Menus are broken down according to modules where the user can view instrument readings, setpoints and alarms.
- *Predictive Diagnostics:* Smart module diagnostics, which shows possible future issues.
- *Maintenance History:* Allows the user to set up a maintenance schedule and track maintenance history.
- *File Sharing and Support:* File sharing via email. Support through Thermo Fisher Scientific technical support.
- *Firmware Version:* Shows the instrument's firmware version.

## Status and Alarms

The Status and Alarms screen provides information with respect to module alarms. In each screen, instrument readings, setpoints, and low/high alarm values are displayed. If applicable, setpoints and alarms are also settable from the Settings>Instrument Settings screen.

**Note**  This symbol denotes there is an active alarm in the module. ▲

### Home Screen>Settings>Health Check>Status and Alarms



The Status and Alarms screen contains the following information:

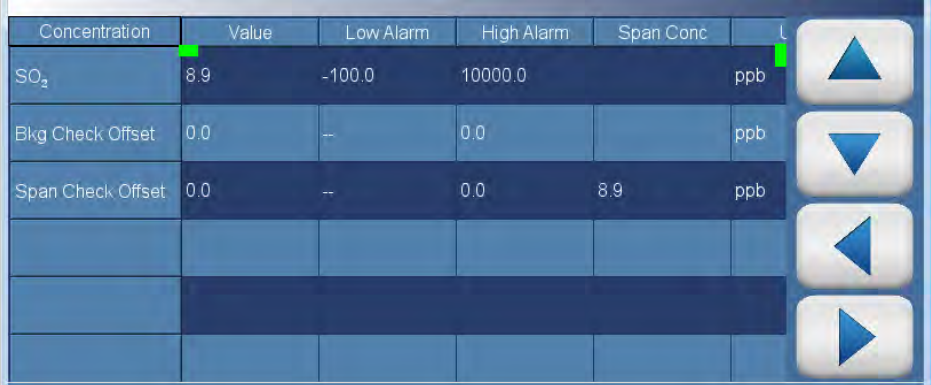
- *Concentration*: Displays SO<sub>2</sub> concentrations, alarms, and calibration pass/fail status.
- *SO<sub>2</sub> Bench*: Displays bench module alarms and faults.
- *Perm Oven*: Displays perm oven module alarms and faults.
- *Flow and Pressure*: Displays flow and pressure alarms and faults.
- *Peripherals Support*: Displays peripherals support alarms and faults.
- *Analog I/O*: Displays analog input/output alarms and faults.
- *Digital I/O*: Displays digital input/output alarms and faults.
- *Valve and Pump Resets*: User can reset valve and pump power.
- *Serial Numbers*: Displays all the serial numbers for the instrument.

## Concentration

The Concentration screen provides status and alarms for SO<sub>2</sub> concentration, background cal/checks, and span cal/checks. If the item being monitored goes outside the lower or higher alarm limit, an alarm is activated.

Use the ▲ and ▼ buttons to move up and down and the ◀ and ▶ buttons to move left and right.

**Home Screen>Settings>Health Check>Status and Alarms>Concentration**



Concentration	Value	Low Alarm	High Alarm	Span Conc	Units
SO <sub>2</sub>	8.9	-100.0	10000.0		ppb
Bkg Check Offset	0.0	--	0.0		ppb
Span Check Offset	0.0	--	0.0	8.9	ppb

The Concentration screen contains the following information:

- Across:
  - *Concentration*: This column lists items associated with the SO<sub>2</sub> concentration.
  - *Value*: Displays the current value for each item.
  - *Low Alarm*: Displays low alarm for each item.
  - *High Alarm*: Displays high alarm for each item.
  - *Span Conc*: Span concentration used in the span calibration or span check.
  - *Units*: Displays units for each item.
- Down:
  - *SO<sub>2</sub>*: SO<sub>2</sub> concentration.
  - *Bkg Check Offset*: Displays concentration based on the last attempted background calibration. High alarm shows user defined limit for acceptable background check offset.

- *Span Check Offset*: Displays concentration based on the last attempted span calibration. High alarm shows user defined limit for acceptable span check offset (compared to the span concentration value). Span concentration shows span setpoint.

**Note** If both the low alarm and high alarms are set to zero, then no alarm will show. ▲

**SO<sub>2</sub> Bench** The SO<sub>2</sub> Bench screen provides status and alarms related to the SO<sub>2</sub> bench module. If an item being monitored goes outside the lower or higher alarm limit, an alarm is activated.

Use the ▲ and ▼ buttons to move up and down and the ◀ and ▶ buttons to move left and right.

**Home Screen>Settings>Health Check>Status and Alarms>SO<sub>2</sub> Bench**

SO <sub>2</sub> Bench	Value	Low Alarm	High Alarm	Units
Chamber Temperature	45.0	44.0	46.0	°C
Lamp Intensity	102.5	90.0	105.0	%
Lamp Voltage	812.4	600.0	1400.0	V
PMT Supply Voltage	-606.8			V
Bench Pressure	730.3			mmHg
Flow	0.458			L/min

The SO<sub>2</sub> Bench screen contains the following information:

- Across:
  - *SO<sub>2</sub> Bench*: This column lists items associated with the SO<sub>2</sub> bench.
  - *Value*: Displays the current value for each item.
  - *Low Alarm*: Displays low alarm for each item.
  - *High Alarm*: Displays high alarm for each item.
  - *Units*: Displays units for each item.
- Down:
  - *Chamber Temperature*: Displays the current chamber temperature. User can adjust low and high alarm limits.
  - *Lamp Intensity*: Displays the current lamp intensity reading. User can adjust low and high alarm limits.
  - *Lamp Voltage*: Displays the current lamp voltage. User can adjust low and high alarm limits.
  - *PMT Supply Voltage*: Displays the current PMT supply voltage.
  - *Bench Pressure*: Displays the current bench pressure reading.
  - *Flow*: Displays the current sample flow reading.

- *Instrument Temp*: Displays the current instrument temperature reading.
- *Board Communication*: Displays OK/Fail for board communication status.
- *Power Supply*: Displays OK/Fail of power supplies. Power supply goes red if any voltages are outside their limits. No voltage rows ever get highlighted.
  - *3.3V Diagnostic*: Displays current voltage readings. Alarm limits are not changeable.
  - *5V Diagnostic*: Displays current voltage readings. Alarm limits are not changeable.
  - *15V Diagnostic*: Displays current voltage readings. Alarm limits are not changeable.
  - *24V Diagnostic*: Displays current voltage readings. Alarm limits are not changeable.

**Perm Oven** The Perm Oven screen provides status and alarms for the permeation oven, if installed. If an item being monitored goes outside the lower or higher alarm limit, an alarm is activated.

Use the ▲ and ▼ buttons to move up and down and the ◀ and ▶ buttons to move left and right.

**Home Screen>Settings>Health Check>Status and Alarms>Perm Oven**

Perm Oven	Value	Low Alarm	High Alarm	Units
Perm Oven Temperature	0.00	29.90	30.10	°C
Board Communication	Fail			
Power Supply	OK			
Heater Power Diagnostics	0.0	0.0	12.0	V
5 V Diagnostics	0.00	4.50	5.50	V
3.3 V Diagnostics	0.00	2.97	3.63	V

The Perm Oven screen contains the following information:

- Across:
  - *Perm Oven*: This column lists items associated with the perm oven.
  - *Value*: Displays the current value for each item.
  - *Low Alarm*: Displays low alarm for each item.
  - *High Alarm*: Displays high alarm for each item.
  - *Units*: Displays units for each item.
- Down:
  - *Perm Oven Temperature*: Displays the current perm oven temperature. User can adjust low and high alarm limits.
  - *Board Communication*: Displays OK/Fail for board communication status.
  - *Power Supply*: Displays OK/Fail of power supplies. Power supply goes red if any voltages are outside their limits. No voltage rows ever get highlighted.
  - *Heater Power Diagnostics*: Displays current heater voltage readings. Alarm limits are not changeable.

- *5 V Diagnostics*: Displays current voltage readings. Alarm limits are not changeable.
- *3.3 V Diagnostics*: Displays current voltage readings. Alarm limits are not changeable.
- *3 V Diagnostics*: Displays current voltage readings. Alarm limits are not changeable.
- *2.5 V Diagnostics*: Displays current voltage readings. Alarm limits are not changeable.

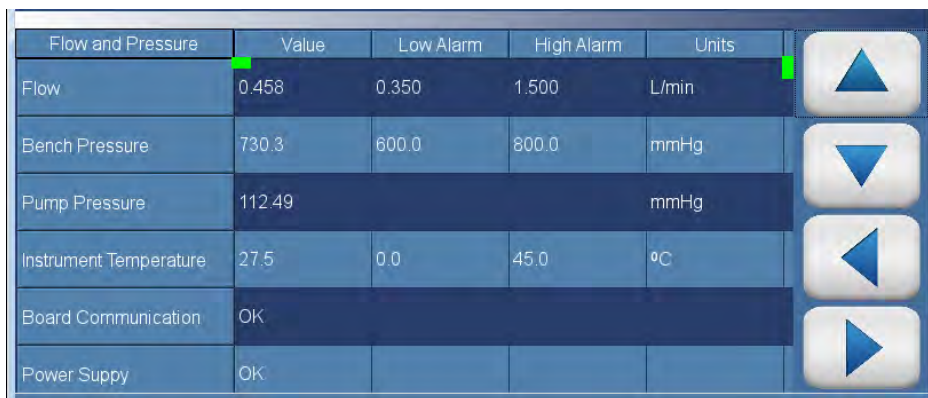


## Flow and Pressure

The Flow and Pressure screen provides status and alarms related to the flow and pressure module. If an item being monitored goes outside the lower or higher alarm limit, an alarm is activated.

Use the ▲ and ▼ buttons to move up and down and the ◀ and ▶ buttons to move left and right.

**Home Screen>Settings>Health Check>Status and Alarms>Flow and Pressure**



Flow and Pressure	Value	Low Alarm	High Alarm	Units
Flow	0.458	0.350	1.500	L/min
Bench Pressure	730.3	600.0	800.0	mmHg
Pump Pressure	112.49			mmHg
Instrument Temperature	27.5	0.0	45.0	°C
Board Communication	OK			
Power Supply	OK			

The Flow and Pressure screen contains the following information:

- Across:
  - *Flow and Pressure*: This column lists items associated with the flow and pressure module.
  - *Value*: Displays the current value for each item.
  - *Low Alarm*: Displays low alarm status for each item.
  - *High Alarm*: Displays high alarm status for each item.
  - *Units*: Displays units for each item.
- Down:
  - *Flow*: Displays the current sample flow reading. User can adjust low and high alarm limits.
  - *Bench Pressure*: Displays the current bench pressure reading. User can adjust low and high alarm limits.
  - *Pump Pressure*: Displays the current pump pressure reading.
  - *Instrument Temperature*: Displays the current instrument temperature reading. User can adjust low and high alarm limits.

- *Board Communication:* Displays OK/Fail for board communication status.
- *Power Supply:* Displays OK/Fail of power supplies. Power supply goes red if any voltages are outside their limits. No voltage rows ever get highlighted.
  - *2.5V Diagnostic:* Displays current voltage readings. Alarm limits are not changeable.
  - *3.3V Diagnostic:* Displays current voltage readings. Alarm limits are not changeable.
  - *5.0V Diagnostic:* Displays current voltage readings. Alarm limits are not changeable.
  - *24V Diagnostic:* Displays current voltage readings. Alarm limits are not changeable.

## Peripherals Support

The Peripherals Support screen provides status and alarms related to the peripheral module. If an item being monitored goes outside the lower or higher alarm limit, an alarm is activated.

Use the ▲ and ▼ buttons to move up and down and the ◀ and ▶ buttons to move left and right.

**Home Screen>Settings>Health Check>Status and Alarms> Peripherals Support**

Peripherals Support	Value	Low Alarm	High Alarm	Units
Module Temperature	28.7			°C
Sample Valve	128.906			mA
Zero Valve	105.703			mA
Span Valve	0.000			mA
Instrument Error	OK			
Board Communication	OK			


The Peripherals Support screen contains the following information:

- Across:
  - *Peripherals Support*: This column lists items associated with the peripherals support module.
  - *Value*: Displays the current value for each item.
  - *Low Alarm*: Displays low alarm status for each item.
  - *High Alarm*: Displays high alarm status for each item.
  - *Units*: Displays units for each item.
- Down:
  - *Module Temperature*: Displays the current module temperature of the module.
  - *Sample Valve*: Displays whether or not the sample valve is activated.
  - *Zero Valve*: Displays whether or not the zero valve is activated.
  - *Span Valve*: Displays whether or not the span valve is activated.
  - *Instrument Error*: Displays OK/Fail for PCP, datalogging, streaming, serial server, and Modbus protocols.

- *Board Communication*: Displays OK/Fail for board communication status.
- *Power Supply*: Displays OK/Fail of power supplies. Power supply goes red if any voltages are outside their limits. No voltage rows ever get highlighted.
  - *2.5V Diagnostic*: Displays current voltage readings. Alarm limits are not changeable.
  - *3.3V Diagnostic*: Displays current voltage readings. Alarm limits are not changeable.
  - *5.0V Diagnostic*: Displays current voltage readings. Alarm limits are not changeable.
  - *24V Diagnostic*: Displays current voltage readings. Alarm limits are not changeable.
  - *5.0V Step Board 1*: Displays current voltage readings. Alarm limits are not changeable.
  - *24V Step Board 1*: Displays current voltage readings. Alarm limits are not changeable.
  - *5.0V Step Board 2*: Displays current voltage readings. Alarm limits are not changeable.
  - *24V Step Board 2*: Displays current voltage readings. Alarm limits are not changeable.

## Valve and Pump Resets

The Valve and Pump Resets screen allows the user to reset a valve or pump after a failure due to excessive amperage.

**Note**  This symbol denotes that the device needs to be reset. ▲

**Note** Resetting one valve will reset all valves. ▲

### Home Screen>Settings>Health Check>Status and Alarms>Valve and Pump Resets



The Valve and Pump Resets screen contains the following information:

- *Sample Valve Reset*: Resets sample valve.
- *Zero Valve Reset*: Resets zero valve.
- *Span Valve Reset*: Resets span valve.
- *Pump Reset*: Resets pump.

**Analog I/O** The Analog I/O screen provides status and alarms related to the analog input/output module. If an item being monitored goes outside the lower or higher alarm limit, an alarm is activated.

Use the ▲ and ▼ buttons to move up and down and the ◀ and ▶ buttons to move left and right.

**Home Screen>Settings>Health Check>Status and Alarms>Analog I/O**

Analog IO	Value	Low Alarm	High Alarm	Units
Voltage Output Channel 1	OK			
Voltage Output Channel 2	OK			
Voltage Output Channel 3	OK			
Voltage Output Channel 4	OK			
Voltage Output Channel 5	OK			
Voltage Output Channel 6	OK			

The Analog I/O screen contains the following information:

- Across:
  - *Analog IO*: This column lists items associated with the analog I/O.
  - *Value*: Displays the current value for each item.
  - *Low Alarm*: Displays low alarm status for each item.
  - *High Alarm*: Displays high alarm status for each item.
  - *Units*: Displays units for each item.
- Down:
  - *Voltage Output Channel 1–6*: Displays real-time voltage output for each channel.
  - *Current Output Channel 1–6*: Displays real-time current output for each channel.
  - *Chip Temperatures*: Displays OK/Fail for chip temperatures.
  - *Chip 1–3 Communication*: Displays OK/Fail for each chip communication.
  - *Test Mode*: Displays test mode on or off.

- *Board Communication*: Displays OK/Fail for board communication status.
- *Power Supply*: Displays OK/Fail of power supplies. Power supply goes red if any voltages are outside their limits. No voltage rows ever get highlighted.
  - *3.3V Diagnostic*: Displays current voltage readings. Alarm limits are not changeable.
  - *5.0V Diagnostic*: Displays current voltage readings. Alarm limits are not changeable.
  - *5.0V Ref Diagnostic*: Displays current voltage readings. Alarm limits are not changeable.
  - *15V Diagnostic*: Displays current voltage readings. Alarm limits are not changeable.
  - *-15V Diagnostic*: Displays current voltage readings. Alarm limits are not changeable.

**Digital I/O** The Digital I/O screen provides status and alarms related to the digital input/output module. If an item being monitored goes outside the lower or higher alarm limit, an alarm is activated.

Use the ▲ and ▼ buttons to move up and down and the ◀ and ▶ buttons to move left and right.

**Home Screen>Settings>Health Check>Status and Alarms>Digital I/O**

Digital IO	Value	Reset	Low Alarm	High Alarm	Units
Solenoid 1	0.0	Reset	OK	OK	mA
Solenoid 2	0.0	Reset	OK	OK	mA
Solenoid 3	0.0	Reset	OK	OK	mA
Solenoid 4	0.0	Reset	OK	OK	mA
Solenoid 5	0.0	Reset	OK	OK	mA
Solenoid 6	0.0	Reset	OK	OK	mA

The Digital I/O screen contains the following information:

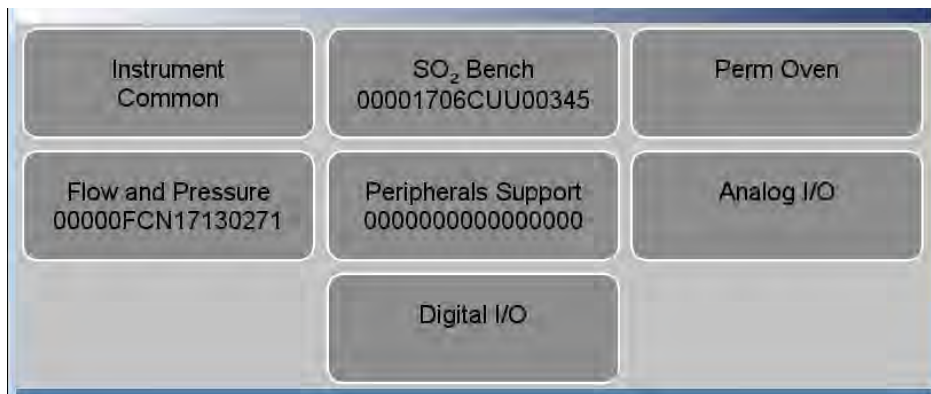
- Across:
  - *Digital IO*: This column lists items associated with the digital I/O.
  - *Value*: Displays the current value for each item.
  - *Reset*: Resets item.
  - *Low Alarm*: Displays low alarm status for each item.
  - *High Alarm*: Displays high alarm status for each item.
  - *Units*: Displays units for each item.
- Down:
  - *Solenoid 1–8*: Displays whether or not the solenoid is activated by showing the current in mA.
  - *External Alarm 1–3*: Displays OK/Fail for external alarms.
  - *Relay Test Mode*: Displays relay test mode on or off.
  - *Solenoid Test Mode*: Displays solenoid test mode on or off.
  - *Board Communication*: Displays OK/Fail for communication status.



- *Power Supply*: Displays OK/Fail of power supplies. Power supply goes red if any voltages are outside their limits. No voltage rows ever get highlighted.
- *3.3V Diagnostic*: Displays current voltage readings. Alarm limits are not changeable.
- *5.0V Diagnostic*: Displays current voltage readings. Alarm limits are not changeable.
- *24V Diagnostic*: Displays current voltage readings. Alarm limits are not changeable.

**Serial Numbers** The Serial Numbers screen displays the serial number for each module.

**Home Screen>Settings>Health Check>Status and Alarms>Serial Numbers**




The Serial Numbers screen contains the following information:

The Serial Numbers screen contains the following information:

- *Instrument*: Instrument serial number.
- *SO<sub>2</sub> Bench*: SO<sub>2</sub> bench serial number.
- *Perm Oven*: Optional perm oven serial number.
- *Flow and Pressure*: Flow and pressure serial number.
- *Peripherals Support*: Peripherals support serial number.
- *Analog I/O*: Analog I/O serial number.
- *Digital I/O*: Digital I/O serial number.

## Predictive Diagnostics

The Predictive Diagnostics screen is a feature that allows the instruments to anticipate maintenance needs, reduce downtime, and reduce troubleshooting time. If button is greyed out, no maintenance is needed. If button is blue, maintenance is suggested.

**Note**  This symbol denotes there is an active maintenance related warning in the module. ▲

### Home Screen>Settings>Health Check>Predictive Diagnostics



The Predictive Diagnostics screen contains the following information:

- Sample Pump
- Capillary
- Flow Path
- Sample Valve
- Zero Valve
- Span Valve

**Maintenance** The Maintenance screen reminds the user when certain instrument components need to be serviced/replaced.

**Home Screen>Settings>Health Check>Maintenance**



The Maintenance screen contains the following information:

- *Preventive Maintenance*: Shows suggested service interval and time left for component replacement.
- *Change Part*: User logs component fix.
- *Maintenance History*: Shows the log of all recorded component fixes.
- *Maintenance History*: Shows the log of all recorded component fixes.
- *Advanced Maintenance*: Resets all preventive maintenance items.

## Preventive Maintenance

The Preventive Maintenance screen reminds the user when certain instrument components need to be serviced/replaced. When the “Months Left” has decreased to 1, the row is highlighted yellow. If the “Months Left” is 0 or less, the row is highlighted red and the maintenance icon (gears) will appear in the status bar located at the bottom of the screen.

Use the ▲ and ▼ buttons to move up and down and the ◀ and ▶ buttons to move left and right.

### Home Screen>Settings>Health Check>Maintenance>Preventive Maintenance

Component	Interval in Months	Months Left	Reset	Alert
Optical Bench Module	48	47	Reset	Enabled
UV Lamp	12	11	Reset	Enabled
PMT	48	47	Reset	Enabled
PMT Base Socket	48	47	Reset	Enabled
Flash Intensity Assy	48	47	Reset	Enabled
Mirrors	60	59	Reset	Enabled

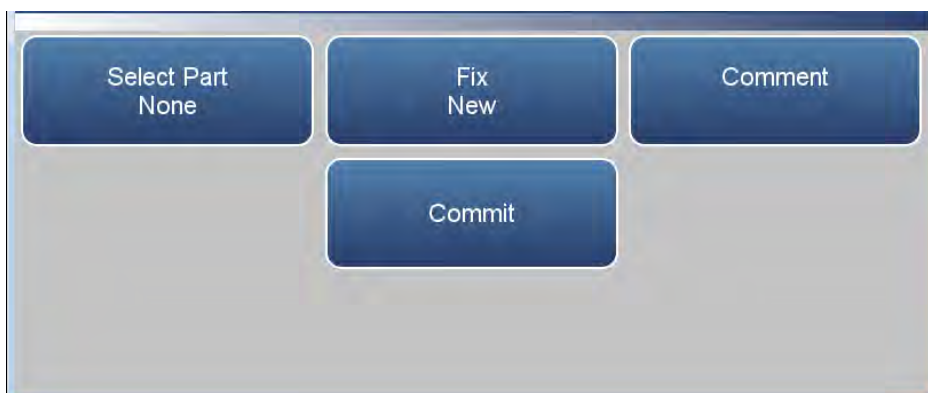
The Preventive Maintenance screen contains the following information:

- Across:
  - *Component*: Device to be routinely serviced or replaced.
  - *Interval in Months*: Expected period of time before a component needs to be checked and/or serviced.
  - *Months Left*: Count down timer in months. Remaining time since the beginning of the service interval. When the value is 1 or less, the row will be highlighted and it is suggested that the component should be checked and/or serviced.
  - *Reset*: Once the component is serviced/replaced, the user presses the Reset button and the “Months Left” value resets to the “Service Interval in Months” value.
  - *Alert*: Allows the user to opt out of receiving preventive maintenance alerts. Displays Enabled/Disabled for each component.

- Down:
  - *Optical Bench Module*: Service interval for optical bench module components.
    - *UV Lamp*: Service interval for UV lamp.
    - *PMT*: Service interval for PMT.
    - *PMT Base Socket*: Service interval for PMT base socket.
    - *Flash Intensity Assembly*: Service interval for flash intensity assembly.
    - *Mirrors*: Service interval for mirrors.
  - *Permeation Tube*: Service interval for permeation tube.
  - *Flow System*: Service interval for the flow system components.
    - *Capillaries*: Service interval for capillaries.
    - *Pump*: Service interval for pump.
  - *DC Power Supply*: Service interval for DC power supply.
  - *Fan Filter*: Service interval for fan filter.
  - *System Components*: Service interval for system components.
    - *Purafil*: Service interval for purafil.
    - *Charcoal*: Service interval for charcoal.
    - *Dri-Rite*: Service interval for dri-rite.

**Change Part** The Change Part screen allows the user to enter the component being serviced and the type of fix. Pressing commit will update the preventive maintenance table and predictive diagnostics screen when applicable.

**Home Screen>Settings>Health Check>Maintenance>Change Part**



The Change Part screen contains the following information:

- *Select Part:* User selects part to service from the selection table.
- *Fix:* User chooses from new, rebuilt, cleaned, and unknown.
- *Comment:* User can write a brief comment, which will be saved to the preventive maintenance history table.
- *Commit:* User commits and saves the selected part fix.

## Maintenance History

The Maintenance History screen allows the user to view when components are replaced, rebuilt, or cleaned. When a user changes a part in the change part screen, the new row will be automatically created at the top in the maintenance history table.

Use the ▲ and ▼ buttons to move up and down and the ◀ and ▶ buttons to move left and right.

**Home Screen>Settings>Health Check>Maintenance>Maintenance History**

**Note** Retrieving maintenance history data, it may take a few seconds... ▲

Part	Fix	Date	Service Months	Comments
All	Unknown	07/17/2017	0	Reset All

The Maintenance History screen contains the following information:

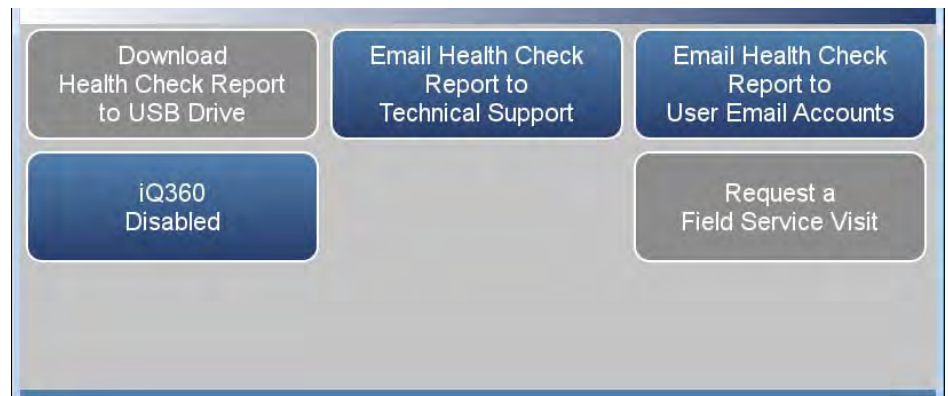
- *Part*: Component that has been fixed.
- *Fix*: The type of maintenance.
- *Date*: Shows date/time when service was logged.
- *Service Months*: Amount of time in months since last service.
- *Comments*: Shows comments entered from time of change.



## File Sharing and Support

The File Sharing and Support screen allows the user to send health check report files to Thermo Fisher Scientific technical support or user emails. The Health Report file includes: Status and Alarms, PM Alerts, Activity Log, Service Database, Cal History, and Data Log (last 24 hours).

### Home Screen>Settings>Health Check>File Sharing and Support



The File Sharing and Support screen contains the following information:

- *Download Health Check Report to USB Drive:* Sends the health report to USB drive.
- *Email Health Check Report File to Technical Support:* Sends the health report file to technical support and the customer email addresses via email.
- *Email Health Check Report to Personal Account:* Sends the health report file to a personal account via email.
- *iQ360:* The iQ360 feature is a paid subscription enabling or disabling the instrument to send automated emails to technical support when an alarm or alert is triggered.
- *Request a Field Service Visit:* Sends a field service visit to technical support.

## Measurement Settings

The Measurement Settings screen contains a number of submenus where instrument parameters and settings can be read and modified.

The following screens show the measurement settings in single range mode and dual or auto range mode. In the dual and auto range modes, both the “High Range” or “Low Range ” buttons averaging buttons will be available.

### Home Screen>Settings>Measurement Settings (single range mode)



### Home Screen>Settings>Measurement Settings (dual or auto range mode)



The Measurement Settings screen contains the following information:

- *Averaging Time*: Sets the averaging time for the SO<sub>2</sub> sample measurement when in single gas mode.
- *Range Mode Selection*: User can choose between the various range modes: single, dual, or auto. For more information, see “[Range Mode Selection](#)” on page 3-65
- *Range Setting*: Sets the concentration range for the analog outputs when in single range mode.

**Operation**  
Settings

- *High Range Setting*: Sets the high range concentration range for the analog output when in dual or auto range mode.
- *Low Range Setting*: Sets the low range concentration for the analog output when in dual or auto range mode.
- *Gas Mode*: User can manually choose sample, zero or span mode.
- *Gas Units*: Defines the units in which SO<sub>2</sub> concentration reading is expressed.
- *Dilution Ratio*: Serves as a multiplier when dilution gas is utilized.
- *Advanced Measurement Settings*: Advanced settings affecting SO<sub>2</sub> readings.

## Averaging Time

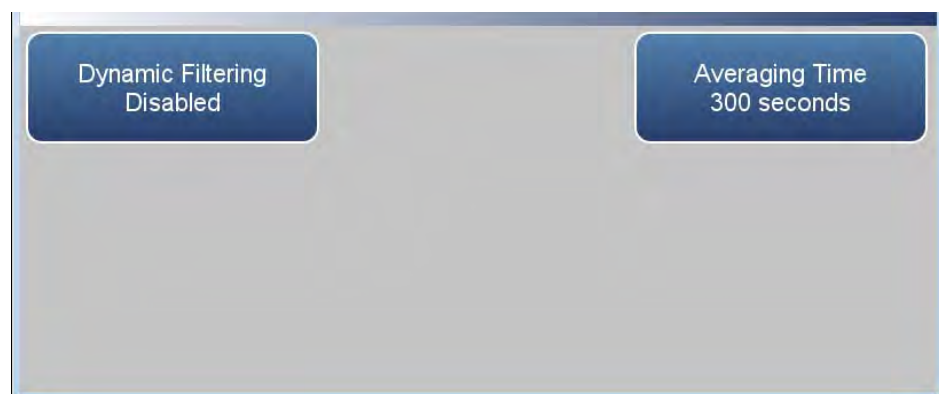
The Averaging Time screen allows the user to choose dynamic filtering or a manually selected (static) averaging time.

Averaging Time defines the time period (1 to 300 seconds) during which SO<sub>2</sub> measurements are taken. The average concentration of the readings are calculated for that time period. The front panel display and analog outputs are updated every second if averaging time is greater than 1 second. An averaging time of 10 seconds, for example, means that the average concentration of the last 10 seconds will be displayed at each update. An averaging time of 300 seconds means that the moving average concentration of the last 300 seconds will be the output at each update (every 10 seconds). Therefore, the lower the averaging time the faster the front panel display and analog outputs respond to concentration changes. Longer averaging times are typically used to smooth output data.

Dynamic Filtering allows for data smoothing without compromising response time. The instrument automatically changes the averaging time giving the user faster response times when conditions are rapidly changing; smoother and stable readings, when conditions aren't changing as rapidly; and as an added bonus, it better processes spikes to minimize their impact on the data. At the same time it will preserve the representative nature of the filtered data to the conditions being sampled.

**Note** When Dynamic Filtering is selected, the user selected Averaging Time button is disabled. ▲

**Home Screen>Settings>Measurement Settings>Averaging Time (single range mode)**



**Home Screen>Settings>Measurement Settings>Averaging Time (dual or auto range mode)**



The Averaging Time screen contains the following information:

- *Dynamic Filtering:* Enables/disables dynamic filtering when in single range mode.
- *High Range Dynamic Filtering:* Enables/disables high range dynamic filtering when in dual or auto range mode.
- *Low Range Dynamic Filtering:* Enables/disables low range dynamic filtering when in dual or auto range mode.
- *Averaging Time:* Sets averaging time period in single range mode and when dynamic filtering is disabled.
- *High Range Averaging Time:* Sets high averaging time when in dual or auto range mode and when dynamic filtering is disabled.
- *Low Range Averaging Time:* Sets low averaging time when in dual or auto range mode and when dynamic filtering is disabled.

## Range Mode Selection

The Range Mode Selection screen is used to switch between the various range modes: Single, Dual, and Auto Range.

**Home Screen>Settings>Measurement Settings>Range Mode Selection**



The Range Mode Selection screen contains the following information:

- *Single*: In single range mode, there is one range, one averaging time, and one span coefficient.
- *Dual*: In the dual range mode, there are two independent analog outputs. These are labeled simply as the “High Range” and the “Low Range”. Each channel has its own analog output range setting, averaging time, and span coefficient.

This enables the sample concentration reading to be sent to the analog outputs at two different ranges. For example, the low SO<sub>2</sub> analog output can be set to output concentrations from 0 to 50 ppb and the high SO<sub>2</sub> analog output set to output concentrations from 0 to 100 ppb.

In addition, each SO<sub>2</sub> analog output has a span coefficient so that each range can be calibrated separately. This is especially necessary if the two ranges are not close to one another. For example, the low SO<sub>2</sub> range is set to 0–50 ppb and the high SO<sub>2</sub> range is set to 0–10000 ppb.

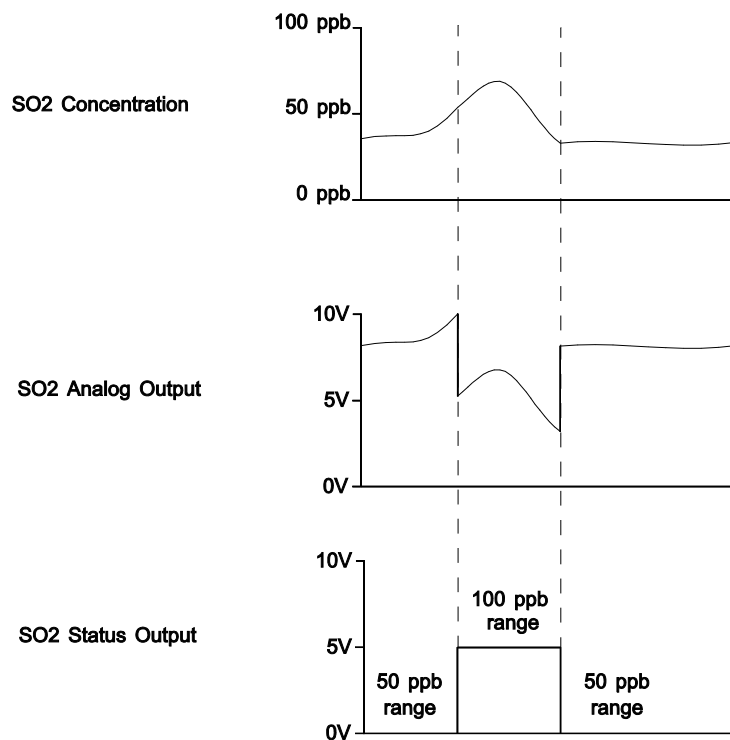
- *Auto*: The auto range mode switches the SO<sub>2</sub> analog outputs between high and low range settings, depending on the concentration level. The high and low ranges are defined in the Range Settings screen.

For example, suppose the low range is set to 50 ppb and the high range is set to 100 ppb, as shown below. Sample concentrations below 50 ppb are output based on low range selection and sample concentrations above 50 ppb are output based on high range selection. When the low range is active, the range mode selection status output is at 0 volts.

When the high range is active, the range mode selection status output is at half of full-scale.

When the high range is active, the concentration must drop to 95% of the low SO<sub>2</sub> range for the low range to become active.

In addition, each SO<sub>2</sub> range and analog output has a span coefficient so that each range can be calibrated separately. This is especially necessary if the two ranges are not close to one another. For example, the low SO<sub>2</sub> range is set to 0–50 ppb and the high SO<sub>2</sub> range is set to 0–10000 ppb.



## Range Setting

The Range Setting screen defines the concentration range of the analog outputs. For example, an SO<sub>2</sub> range of 0–50 ppb restricts the analog output to concentrations between 0 and 50 ppb.

The screen shows the current SO<sub>2</sub> range. The range screen is similar for the single, dual, and auto range modes. The only difference between the screens are the words “High” or “Low” displayed to indicate which range is displayed. For more information about the dual and auto range modes, see “[Range Mode Selection](#)” on page 3-65. Pressing Range Setting, High Range Setting or Low Range Setting, brings up a numeric keypad whereby the user can select a range.

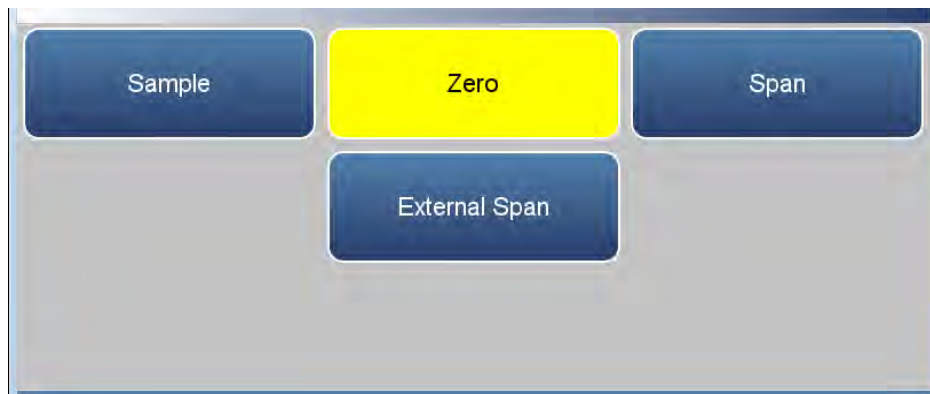
Settable ranges according to unit selection include:

ppb	50–10000 ppb
ppm	0.05–10 ppm
%	5e-06–0.001 %
µg/m <sup>3</sup>	200–25000 µg/m <sup>3</sup>
mg/m <sup>3</sup>	0.2–25 mg/m <sup>3</sup>
g/m <sup>3</sup>	5e-05–0.01 g/m <sup>3</sup>



**Gas Mode** The Gas Mode screen defines what gas mode the instrument is set to.

**Home Screen>Settings>Measurement Settings>Gas Mode**



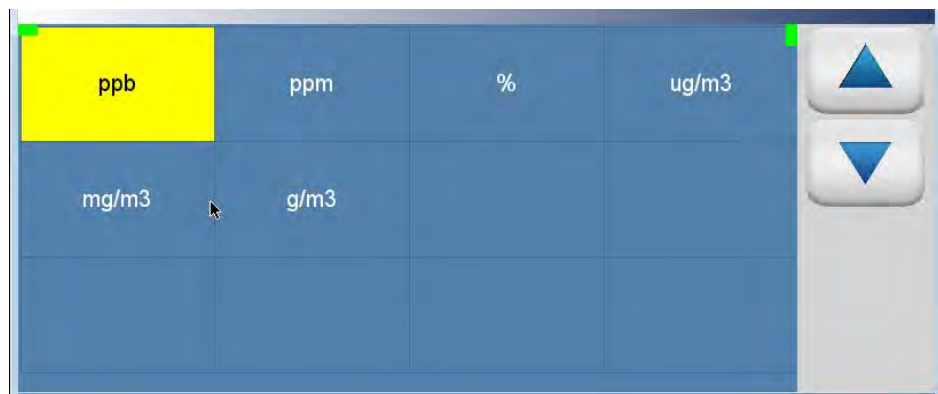
The Gas Mode screen contains the following information:

- *Sample*: Sets the instrument to measure sample gas.
- *Zero*: Used when calibrating the background of the instrument. When pressed, sets the instrument to zero mode.
- *Span*: Used when calibrating the span coefficient. When pressed, sets the instrument to span mode.
- *External Span*: If optional perm oven is installed, allows the use of an external span source in addition to the internal permeation span.

**Gas Units** The Gas Units screen defines how the SO<sub>2</sub> concentration reading is expressed. The  $\mu\text{g}/\text{m}^3$ ,  $\text{mg}/\text{m}^3$ , and  $\text{g}/\text{m}^3$  gas concentration modes are calculated using a standard pressure of 760 mmHg and a standard temperature of 0 °C.

Use the ▲ and ▼ buttons to move up and down.

**Home Screen>Settings>Measurement Settings>Gas Units**



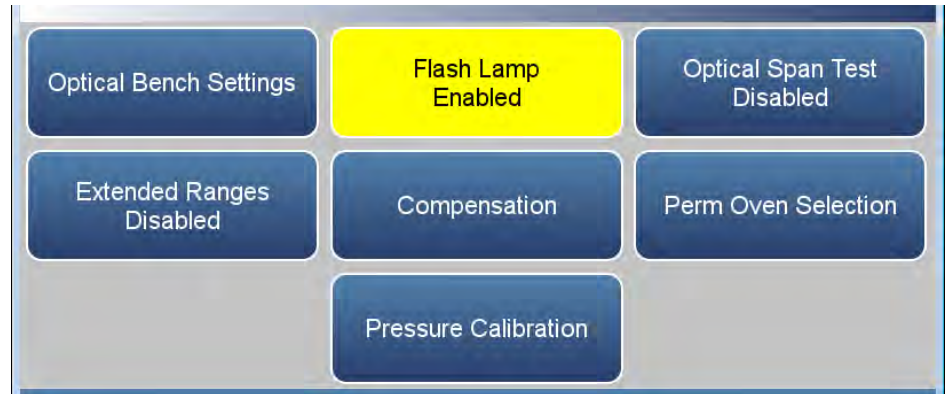
The Gas Units screen contains the following information:

- *ppb*: parts per billion.
- *ppm*: parts per million.
- *%*: percent.
- *$\mu\text{g}/\text{m}^3$* : micrograms per meter cubed.
- *$\text{mg}/\text{m}^3$* : milligrams per meter cubed.
- *$\text{g}/\text{m}^3$* : grams per meter cubed.

## Advanced Measurement Settings

The Advanced Measurement Settings screen allows the user to calibrate the optical bench and set other advanced settings.

**Home Screen>Settings>Measurement Settings>Advanced Measurement Settings**



The Advanced Measurements Settings screen contains the following information:

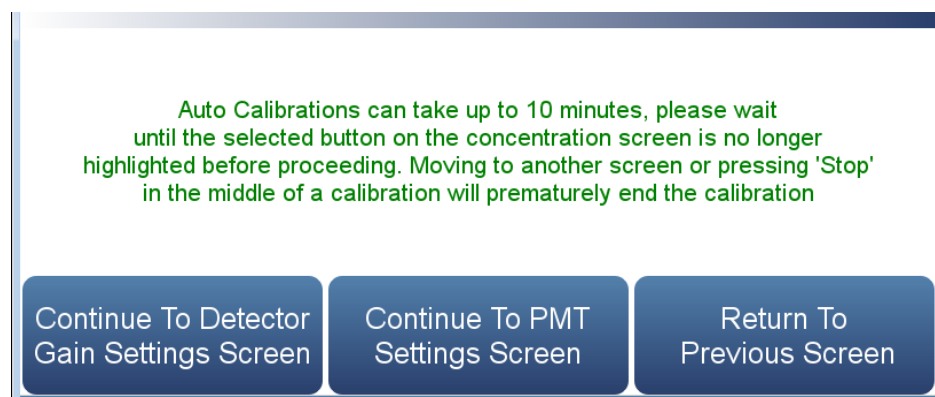
- *Optical Bench Settings*: Calibrates detector gain, PMT supply, flash voltage, and initial flash reference.
- *Flash Lamp*: Enables/Disables flash lamp.
- *Optical Span Test*: Enables/Disables test LED and reads the LED SO<sub>2</sub> concentration.
- *Extended Ranges*: Enables/Disables extended ranges feature.
- *Compensation*: Allows the user to compensate for changes in temperature and pressure concentration.
- *Perm Oven Selection*: Allows the user to select the operating temperature of the perm oven.
- *Pressure Calibration*: Calibrates pressure.

## Optical Bench Settings

The Optical Bench Settings screen allows the user to calibrate the optical bench. The calibration in this screen should be performed if the part associated with the optical bench has been changed/repaired or if the span coefficient is outside the limit of 0.5 to 2.0.

Use the ▲ and ▼ buttons to move up and down and the ◀ and ▶ buttons to move left and right.

**Home Screen>Settings>Measurement Settings>Advanced Measurement Settings>Optical Bench Settings**



**Home Screen>Settings>Measurement Settings>Advanced Measurement Settings>Optical Bench Settings>Continue To Detector Gain Settings Screen**

Description	Detector Gain	Lamp Voltage	Lamp Intensity
Manual Entry	39	0.0	0.0
Auto Cal	Start		
End Cal	Stop		
Default Values	Default Gain		

The Detector Gain Settings screen contains the following information:

- Across:
  - *Description*: Define the actions the user can do.
  - *Detector Gain*: User can manually set or automatically calibrate the detector gain.

- *PMT Supply*: User can manually set or automatically calibrate the photomultiplier tube supply.
- *Lamp Voltage*: Displays the current lamp voltage.
- *Lamp Intensity*: Displays the current lamp intensity.
- Down:
  - *Manual Entry*: Shows current value. If pressed, user can manually set the detector gain value.
  - *Auto Cal*: When pressed, the detector's auto-calibration process is initiated. Please allow up to 5 minutes for calibration to complete. User can stop calibration by pressing the Stop button under Detector Gain.
  - *End Cal*: When pressed, the auto calibration is interrupted and the value does not change.
  - *Default Values*: When pressed, the default gain for the lamp intensity detector is restored.

**Home Screen>Settings>Measurement Settings>Advanced Measurement Settings>Optical Bench Settings>Continue To PMT Settings Screen**

Description	PMT Supply	Current PMT	Units	
Manual PMT Entry	-606.0	-606.8	V	▲
Target Concentration	0.0			▼
Calibration Concentration	3193.8			◀
Auto Calibration	Start			▶
End Calibration	Stop			
Default Values	Default PMT Supply			

The PMT Settings screen contains the following information:

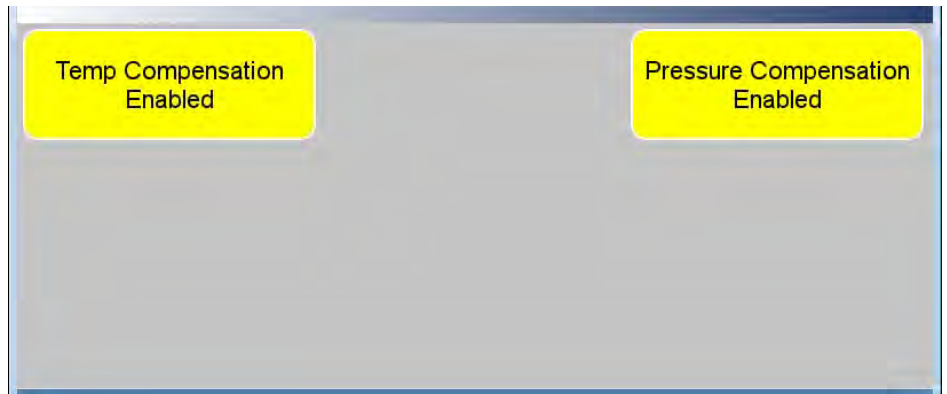
- Across:
  - *Description*: Defines the actions the user can do.
  - *PMT Supply*: User can manually adjust the PMT supply value, read target and calibration concentration, start/stop automatic calibration, read voltage, frequency and zero offset frequency values, and reset default values.
  - *Current PMT*: Displays the current PMT voltage value.

- *Units*: Displays units for each item.
- Down:
  - *Manual Entry*: Shows current value. If the PMT supply cell is pressed, user can manually change the value.
  - *Target Concentration*: Displays target concentration.
  - *Calibration Concentration*: Displays calibration concentration.
  - *Auto Calibration*: When pressed, the auto-calibration process is initiated. Please allow up to 5 minutes for calibration to complete.
  - *End Calibration*: When pressed, the auto calibration is interrupted and the value does not change.
  - *Default Values*: When pressed, the default PMT voltage setting is restored.

## Compensation

The Compensation screen provides compensation for any changes to the instrument's output signal due to internal instrument temperature, and pressure variations.

**Home Screen>Settings>Measurement Settings>Advanced Measurement Settings>Compensation**



The Compensation screen contains the following information:

- *Temp Compensation:* Toggles temperature compensation enabled or disabled and provides compensation for any changes to the instrument's output signal due to internal instrument temperature variations. The effects of internal instrument temperature changes on the analyzer's subsystems and output have been empirically determined. This empirical data is used to compensate for any changes in temperature.
- *Pressure Compensation:* Toggles pressure compensation enabled or disabled and provides compensation for any changes to the instrument's output signal due to bench pressure variations. The effects of bench pressure changes on the analyzer's subsystems and output have been empirically determined. This empirical data is used to compensate for any change in bench pressure.

## Pressure Calibration

The Pressure Calibration screen is used to calibrate the pressure sensor to zero, span, or factory default values.

Use the ▲ and ▼ buttons to move up and down and the ◀ and ▶ buttons to move left and right.

**Home Screen>Settings>Measurement Settings>Advanced Measurement Settings>Pressure Calibration**

Description	Reading	Calibration				
Sensor 1 Reading	780.9					▲
Sensor 2 Reading	159.5					▼
Sensor 3 Reading	771.9					◀
Atmospheric Sensor 1	780.0	Start				▶
Zero Sensor 1	200.0	Start				
Atmospheric Sensor 2	157.0	Start				

The Pressure Calibration screen contains the following information:

- Across:
  - *Description*: Lists items in table.
  - *Reading*: Displays reading of each pressure sensor.
  - *Calibration*: Starts calibration or resets default values.
- Down:
  - *Sensor 1–3 Reading*: Under the column labeled Reading, current reading of each pressure sensor.
  - *Atmospheric Sensor 1–3*: Under the column labeled reading, the user enters the current atmospheric pressure in mmHg units. Under the column labelled Calibration, the user presses the Start button to calibrate the high point of the sensor.
  - *Zero Sensor 1–3*: User should put the pressure sensor under a strong vacuum. Under the column labeled reading, the user enters the pressure in mmHg. Under the column labeled Calibration, the user presses the Start button to calibrate the low point of the sensor.
  - *Reset all values*: Resets values to default.



## Communications

The Communications screen allows the user to set TCP/DHCP parameters, Serial settings, Analog I/O and Digital I/O, Email Server, and Instrument ID. Buttons are grayed out if not selected in Settings>Configuration.

### Home Screen>Settings>More>Communications



The Communications screen contains the following information:

- *Wired TCP/DHCP*: Settings for communicating with the instrument through wired Ethernet.
- *Serial RS-232/485*: Settings for communicating with the instrument through RS-232/485 protocol. This is only visible if selected in Settings>Configuration>Communications Board.
- *Analog I/O*: Settings for communicating with the instrument through analog I/O settings. This is only visible if selected in Settings>Configuration>Analog I/O.
- *Digital I/O*: Settings for communicating with the instrument through digital I/O settings. This is only visible if selected in Settings>Configuration>Digital I/O.
- *Email Server (SMTP)*: Settings for communication with email.
- *Instrument ID*: Allows the user to edit the instrument identification number (ID). The ID is used to identify the instrument when using protocols to control the instrument or collect data. It may be necessary to edit the ID number if two or more of instruments of the same model are connected to one computer. Valid instrument ID numbers are from 0 to 127. The 43iQ has a default instrument ID of 1.

**Wired TCP/DHCP** The Wired TCP/DHCP screen allows the user to communicate with the instrument via wired TCP/IP settings.

**Note** When DHCP is enabled, the dynamic IP address is used. When DHCP is disabled, the static IP address is used. ▲

**Home Screen>Settings>More>Communications> Wired TCP/DHCP (with DHCP enabled)**



**Home Screen>Settings>More>Communications>Wired TCP/DHCP (with DHCP disabled)**



The Wired TCP/DHCP screen contains the following information:

- *DHCP*: Toggles DHCP enabled/disabled.
- *Dynamic IP Address*: Dynamic IP address of the instrument.
- *Dynamic Netmask*: Dynamic Netmask of instrument.
- *Dynamic Gateway*: Dynamic Gateway of instrument.

**Operation**  
Settings

- *Static IP Address*: Static IP address of the instrument. This is settable when DHCP is disabled.
- *Static Netmask*: Static Netmask of instrument. This is settable when DHCP is disabled.
- *Static Gateway*: Static Gateway of instrument. This is settable when DHCP is disabled.
- *DNS Server Address*: DNS IP address of instrument. This is settable when DHCP is disabled.
- *Wired MAC Address*: Instrument MAC address.
- *Host Name*: Host name of instrument.

**Serial RS-232/485** The Serial RS-232/485 screen allows the user to setup serial communication. This is only visible if selected in Settings>Configuration>**Communications Board**.

**Home Screen>Settings>More>Communications>Serial RS-232/485**



The Serial RS-232/485 screen contains the following information:

- *Protocol*: User selects Modbus or Streaming.
- *Baud Rate*: User selectable baud rates from 1200 to 115200.
- *Bits*: User selectable between 7 and 8.
- *Parity*: User selectable between None, Even, and Odd.
- *Stop Bits*: User selectable between 1 and 2.
- *RS 232/485*: User selectable between RS-232 and RS-485.

**Analog I/O** The Analog I/O screen allows for configuring the analog inputs/outputs. This is only visible if selected in Settings>Configuration>**Analog I/O**.

**Home Screen>Settings>More>Communications>Analog I/O**



The Analog I/O screen contains the following information:

- *Analog In*: Allows the user to view and calibrate voltage inputs from external devices.
- *Analog Out (Voltage)*: Allows the user to view voltage outputs from external devices.
- *Analog Out (Current)*: Allows the user to view current (mA) outputs.
- *Analog Out Under/Over Range Enabled/Disabled*: Allows the user to select whether or not the analog outputs are allowed to exceed the selected output range.

**Digital I/O** The Digital I/O screen allows for configuring the digital inputs/outputs. This is only visible if selected in Settings>Configuration>**Digital I/O**.

**Home Screen>Settings>Communications>Digital I/O**

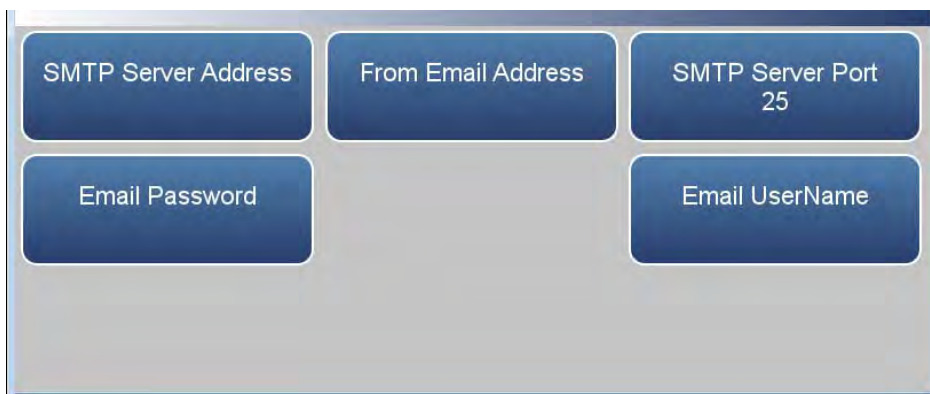


The Digital I/O screen contains the following information:

- *Digital In*: Allows the user to view digital inputs from external devices.
- *Digital Out (Relays)*: Allows the user to view relay outputs.
- *Digital Out (Solenoids)*: Allows the user to view solenoid outputs.
- *Advanced Digital I/O*: Allows user to test the digital out relays and solenoids.

**Email Server (SMTP)** The Email Server (SMTP) screen allows the user to configure their email preferences.

**Home Screen>Settings>More>Communications>Email Server (SMTP)**



The Email Server (SMTP) screen contains the following information:

- *SMTP Server Address*: Address of the user's email server.
- *From Email Address*: The email address that goes in the From field in emails.
- *SMTP Server Port*: Server port of user's email server.
- *Email Password*: Password for SMTP server.
- *Email UserName*: User name that is authorized to send email through SMTP server.

## Instrument Settings

The Instrument Settings screen allows the user to configure various instrument settings.

### Home Screen>Settings>Instrument Settings



The Instrument Settings screen contains the following information:

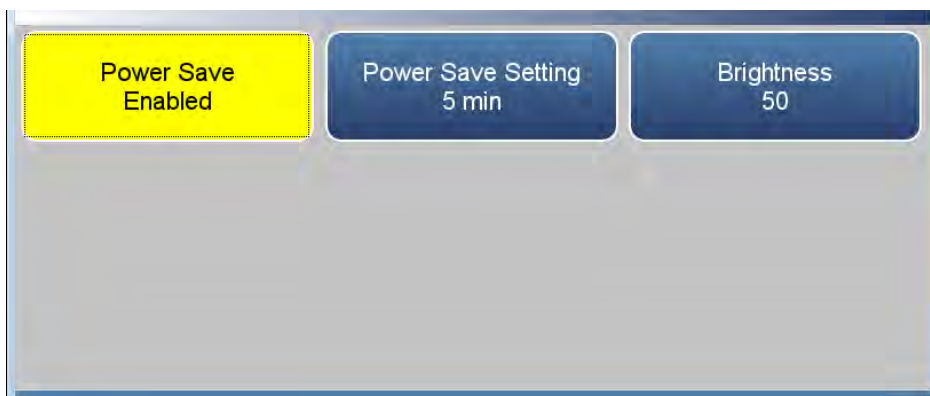
- *Display Setup*: Sets touch screen display settings.
- *Alarm Setpoints*: View and set all available alarm minimum and maximum values.
- *Language*: Read only.
- *Clock*: Sets date and time.
- *Pump Power*: Manually enables/disables the pump.



## Display Setup

The Display Setup allows the user to change the brightness of the display and choose power save option.

**Home Screen>Settings>Instrument Settings>Display Setup**



The Display Setup screen contains the following information:

- *Power Save*: Minutes before screen times out. Toggles enable/disable.
- *Power Save Setting*: Option whereby the user can display a black screen after a set amount of inactivity.
- *Brightness*: Sets the brightness of the display.

**Alarm Setpoints** The Alarm Setpoints screen allows the user to view and set all settable alarm minimum and maximum values.

**Note** User cannot set alarm limits outside of the acceptable range. The minimum and maximum alarm limit can also be set by pressing on the corresponding buttons located in the Settings>Health Check>Status and Alarms screen. See “[Status and Alarms](#)” on page 3-37. ▲

Use the ▲ and ▼ buttons to move up and down and the ◀ and ▶ buttons to move left and right.

**Home Screen>Settings>Instrument Settings>Alarm Setpoints**

Variable	Value	Low Alarm	High Alarm	Units
SO2 Concentration	3200	0.0	0.0	ppb
Bkg Check Offset	0.0	--	0.0	ppb
Span Check Offset	0.0	--	0.0	ppb
Chamber Temperature	44.9	44.0	46.0	°C
Lamp Intensity	0.0	90.0	105.0	%
Lamp Voltage	0.0	600.0	1400.0	V

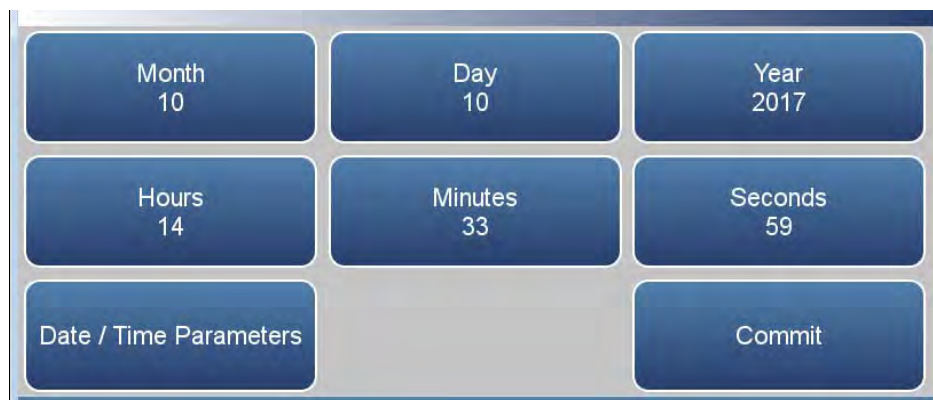
The Alarm Setpoints screen contains the following information:

- Across:
  - *Variable*: Lists the items that have settable alarm limits.
  - *Value*: Displays the current value for each item.
  - *Low Alarm*: User sets low alarm for item.
  - *High Alarm*: User sets high alarm for item.
  - *Units*: Units for each item (not settable).
- Down:
  - *SO2*: SO<sub>2</sub> concentration alarm.
  - *Bkg Check Offset*: User can set the maximum allowable background reading offset for calibration and calibration checks. This is set with the high alarm only.

- *Span Check Offset:* User can set the maximum allowable span reading offset for calibration and calibration checks. This is set with the high alarm only.
- *Chamber Temperature:* Chamber temperature alarm.
- *Lamp Intensity:* Lamp intensity alarm.
- *Lamp Voltage:* Lamp voltage alarm.
- *Instrument Temperature:* Instrument temperature alarm.
- *Bench Pressure:* Bench pressure alarm.
- *Flow:* Flow pressure alarm.
- *Perm Oven Temperature:* Perm oven temperature alarm.

**Clock** The Clock screen allows the user to set the instrument's date and time, choose date/time format, time zone, and time server.

**Home Screen>Settings>Instrument Settings>Clock**



The Clock screen contains the following information:

- Month
- Day
- Year
- Hours
- Minutes
- Seconds
- *Date / Time Parameters*: User chooses time zone, timer server, and date format.
- *Commit*: When pressed, date and time are saved.

## Date / Time Parameters

The Date / Time Parameters screen allows the user to choose time zone, time server and date format.

**Home Screen>Settings>Instrument Settings>Clock>Date / Time Parameters**



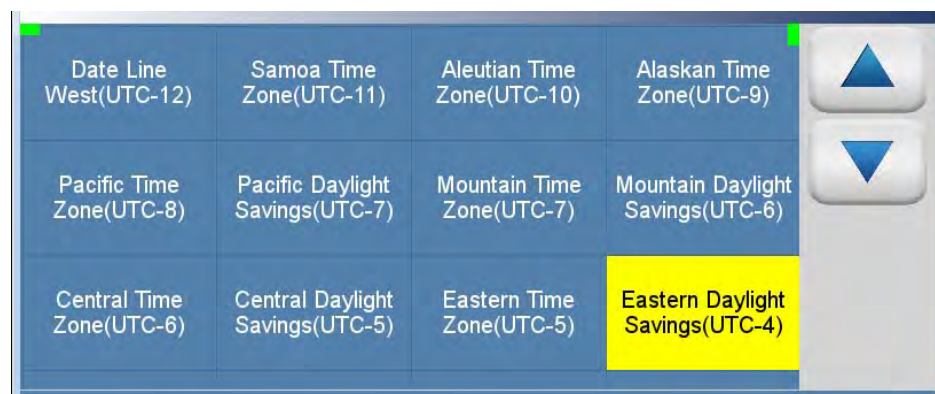
The Date / Time Parameters screen contains the following information:

- *Time Zone:* User selects time zone from table.
- *Time Server Enabled/Disabled:* User can enabled/disable the time server to get periodic clock updates.
- *Date Format:* User selects date format.

**Time Zone** The Time Zone screen allows the user to set the time zone for the Network Time Protocol (NTP) server. This should be set to the time zone that the instrument is located in.

Use the ▲ and ▼ buttons to move up and down.

**Home Screen>Settings>Instrument Settings>Clock>Date / Time Parameters>Time Zone**



The Time Zone screen contains the following information:

- Date Line West(UTC-12)
- Samoa Time Zone(UTC-11)
- Aleutian Time Zone(UTC-10)
- Alaskan Time Zone(UTC-9)
- Pacific Time Zone(UTC-8)
- Pacific Daylight Savings(UTC-7)
- Mountain Time Zone(UTC-7)
- Mountain Daylight Savings(UTC-6)
- Central Time Zone(UTC-6)
- Central Daylight Savings((UTC-5)
- Eastern Time Zone(UTC-5)
- Eastern Daylight Savings(UTC-4)
- Atlantic Time Zone(UTC-4)
- Mid-Atlantic(UTC-3)
- South Georgia(UTC-2)

**Operation**  
Settings

- Cape Verde Time(UTC-1)
- Coordinated Universal Time(UTC-0)
- Central European Time(UTC+1)
- Eastern European Time(UTC+2)
- Further-Eastern European Time(UTC+3)
- Gulf Standard Time(UTC+4)
- Yekaterinburg Time(UTC+5)
- Omsk Time(UTC+6)
- Indochina Time(UTC+7)
- ASEAN Common Time(UTC+8)
- Japan Standard Time(UTC+9)
- Chamorro Time Zone(UTC+10)
- Sredmnekolymsk Time(UTC+11)
- New Zealand Standard Time(UTC+12)

**Time Server** The Time Server screen allows the user to enable/disable the time server to get periodic clock updates.

**Home Screen>Settings>Instrument Settings>Clock>Date / Time Parameters>Time Server**



The Time Server screen contains the following information:

- *Time Server*: Enables/Disables periodic clock updates from an NTP (Network Time Protocol) source.
- *Set Time Server*: User can choose specific time server.
- *Set Default*: When pressed, default time server will be used.



**Date Format** The Date Format screen allows the user to choose from the following formats: mm/dd/yyyy, dd/mm/yyyy or yyyy-mm-dd.

Use the ▲ and ▼ buttons to move up and down.

**Home Screen>Settings>Instrument Settings>Clock>Date / Time Parameters>Date Format**



The Date Format screen contains the following information:

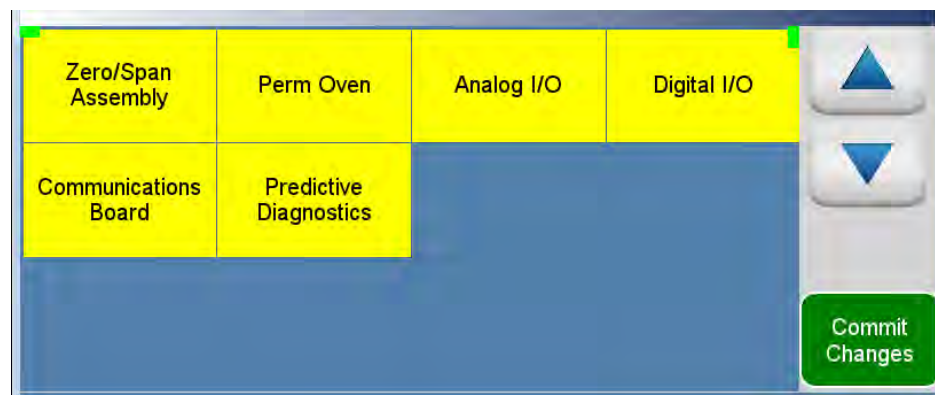
- U.S. Format mm/dd/yyyy
- European Format dd/mm/yyyy
- ISO 8601 yyyy-mm-dd

## Configuration

The Configuration screen allows the user to enable optional features. If an option is disabled, the corresponding buttons will be grayed out and the screens will not be available.

Use the ▲ and ▼ buttons to scroll through the variables. Select the variables to log by pressing the corresponding cells. Next, press the **Commit Changes** button to save selections. Yellow buttons indicate that the variable is selected. More than one can be chosen.

### Home Screen>Settings>Configuration



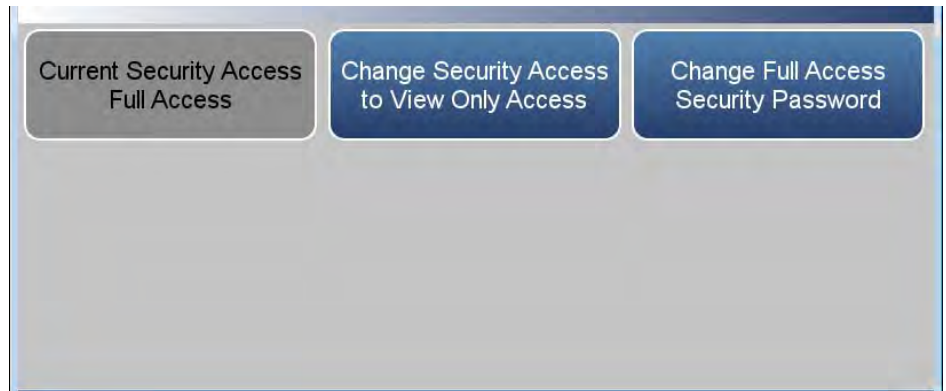
The Configuration screen contains the following information:

- *Zero/Span Assembly*: Enables zero/span valves.
- *Perm Oven*: Enables permeation oven option.
- *Analog I/O*: Enables analog I/O option.
- *Digital I/O*: Enables digital I/O option.
- *Communications Board (RS485)*: Enables RS485 communication board.
- *Predictive Diagnostics*: Enables predictive diagnostics.

## Security Access Levels

The Access Levels screen allows the user to set the instrument to either View Only or Full Access. When in Full Access, the user will have access to all screens. When set to View Only, user will not be able to change any values.

### Home Screen>Settings>Security Access Levels (Full Access)



### Home Screen>Settings>Security Access Levels (View Only Access)



The Security Access Levels screen contains the following information:

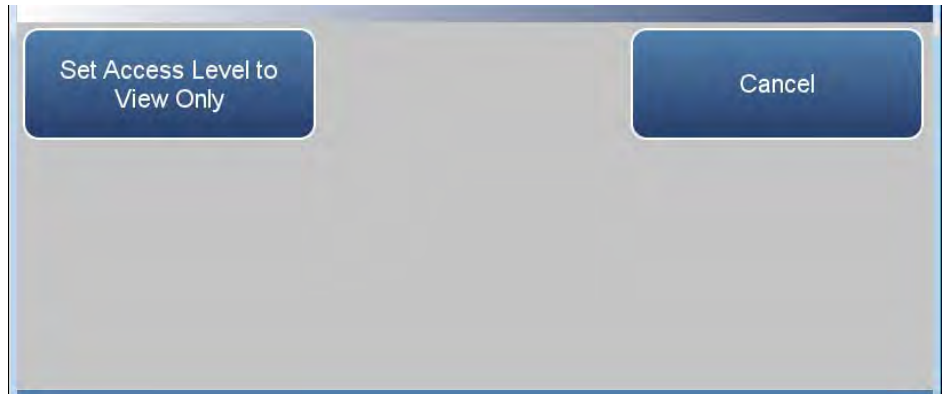
- *Current Security Access Full Access:* Read only. User will be able to change all values. Password is needed for full access.
- *Current Security Access View Only:* Read only. User won't be able to change any values. Password is not needed for view only.
- *Change Security Access to View Only:* User can switch to view only mode. Password not needed to change settings to view only access.
- *Change Security Access to Full Access:* User can switch to full access mode. Password is needed to change settings to full access.

- *Change Full Access Security Password:* Full access password can have a blank value or user selected password.

### Change Security to View Only Access

The Change Security to View Only Access screen allows the user to set the instrument to view only.

**Home Screen>Settings>Security Access Levels>Change Security Access to View Only Access**



The Change Security to View Only Access screen contains the following information:

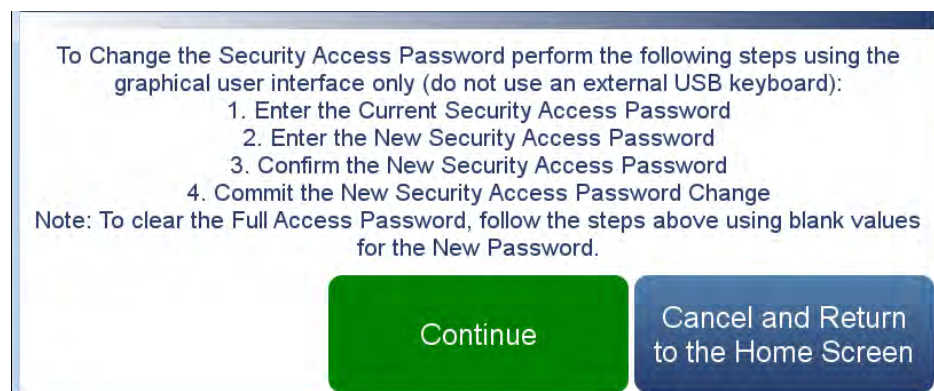
- *Set Access Level to View Only*: Programs the instrument to be in the view only access level, where the user won't be able to change any values.
- *Cancel*: Exit screen.

**Note** To change security access from view only access to full access, a keypad will be displayed where the user can enter full access password. ▲

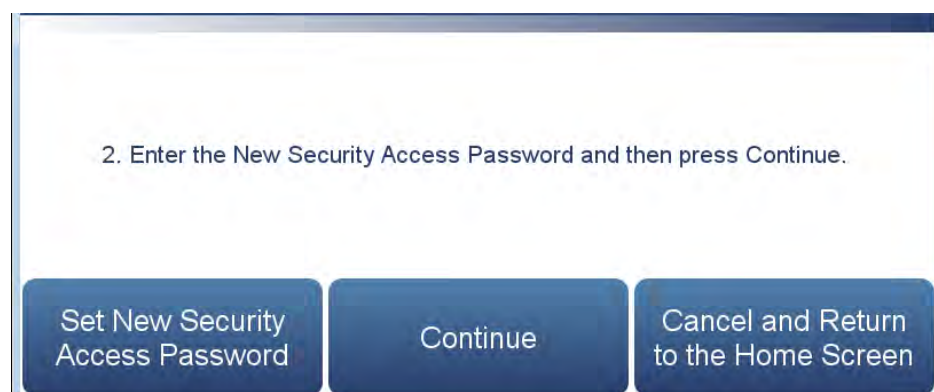
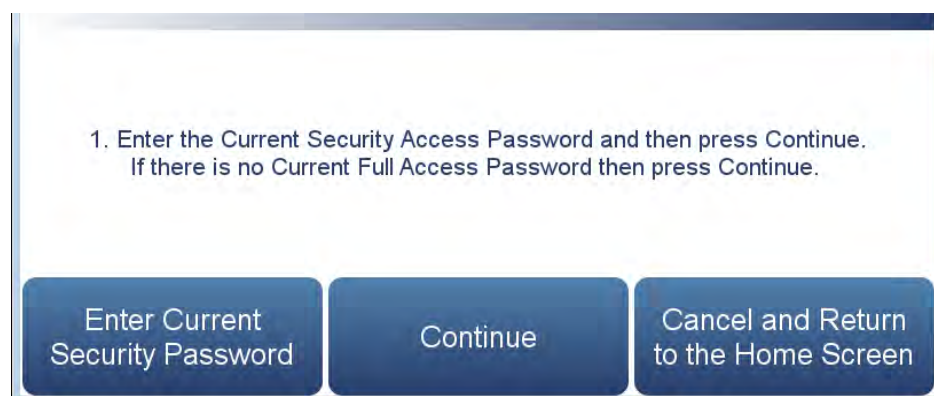
## Change Full Access Security Password

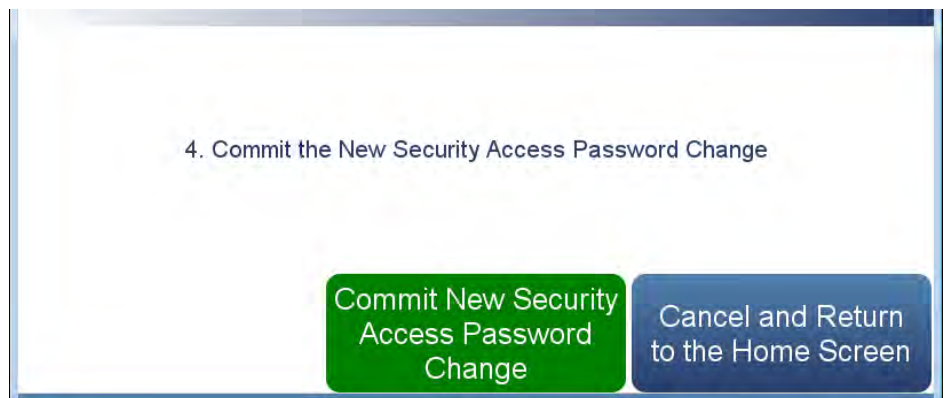
The Change Full Access Security Password screen allows the user to set a new password for allowing full access.

### Home Screen>Settings>Security Access Levels>Change Full Access Security Password



### Home Screen>Settings>Security Access Levels>Change Full Access Security Password>Continue





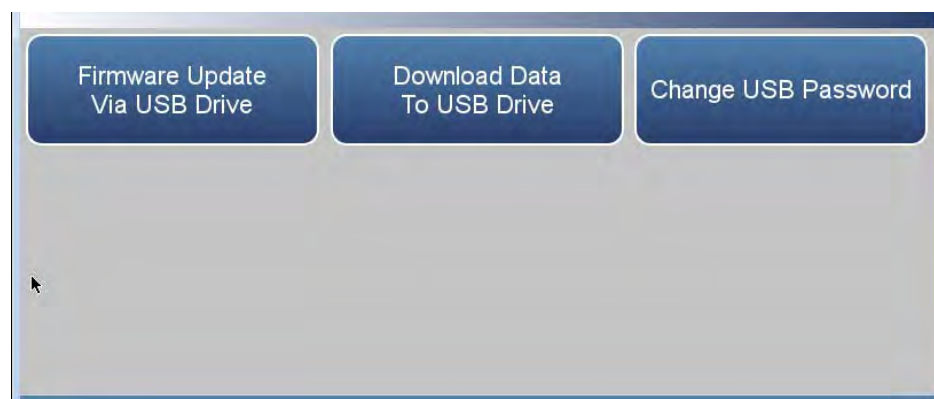
The Change Full Access Security Password screens contain the following information:

- *Enter Current Security Password:* User enters current security password.
- *Continue:* Proceeds to next screen.
- *Enter New Security Access Password:* User enters new security password.
- *Confirm New Security Access Password:* User confirms new security password for spelling confirmation.
- *Commit New Security Access Password Change:* Commits new security password.
- *Cancel and Return to the Home Screen:* Exits screen and returns to the Home Screen without changing password.

**USB Drive** The USB Drive screen allows the user to update firmware, download/upload information, and change the USB password.

**Note** The USB drive screen only is useable when a USB drive is inserted into the USB port. When a USB drive is inserted, the user is prompted to enter the password if a password has been set. ▲

**Home Screen>Settings>USB Drive**



The USB Drive screen contains the following information:

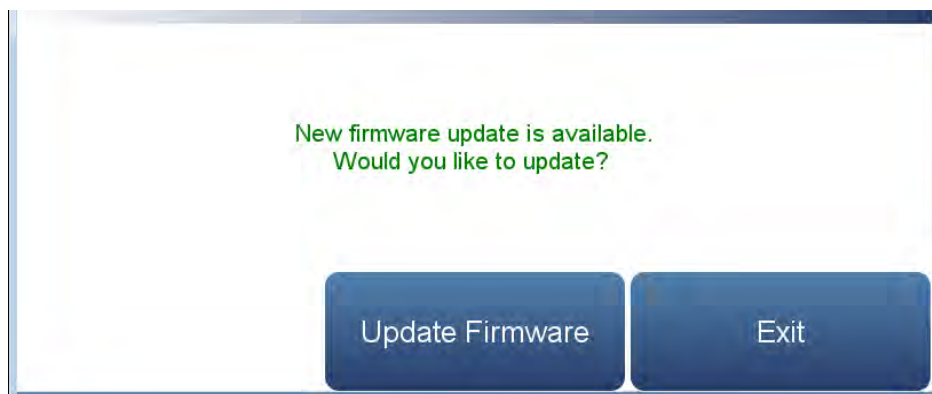
- *Firmware Update Via USB Drive*: If USB is mounted, user can update instrument firmware.
- *Download Data To USB Drive*: User can download/upload information.
- *Change USB Password*: User can change the USB password.



## Firmware Update Via USB Drive

The Firmware Update Via USB Drive screen allows the user to update instrument firmware from the USB drive.

**Home Screen>Settings>USB Drive>Firmware Update Via USB Drive**



The Firmware Update Via USB Drive screen contains the following information:

- *Update Firmware:* User chooses firmware file from USB and updates instrument firmware. Instrument reboots when update is finished.
- *Exit:* User exits without updating firmware.

## Download Data To USB Drive

The Download Data To USB Drive screen allows the user to download/upload data to/from the USB drive.

**Home Screen>Settings>USB Drive>Download Data To USB Drive**

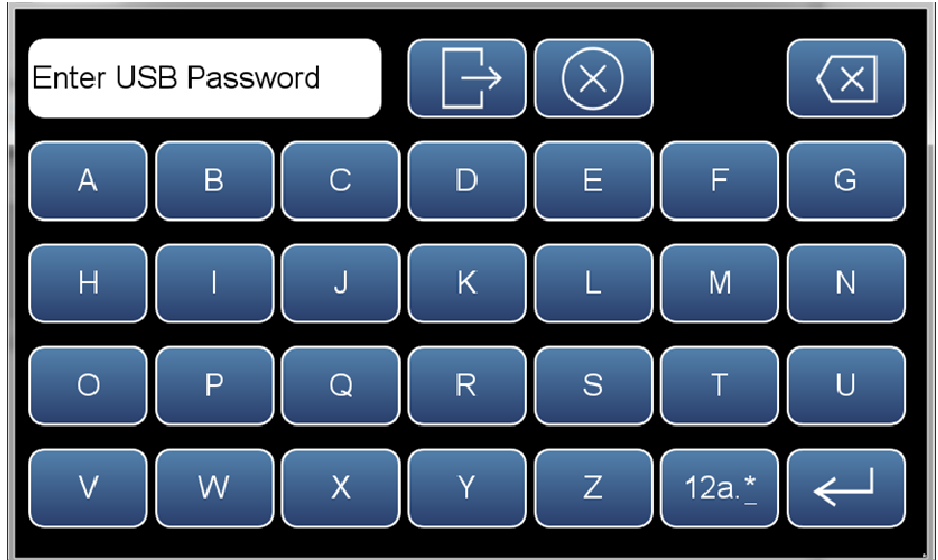


The Download Data to USB Drive screen contains the following information:

- *Download Health Check Report:* Includes status and alarms, preventive maintenance, and maintenance history.
- *Download Entire Data Log:* Includes the entire data log (from data logging).
- *Download Service Log:* Includes a complete listing of data for all variables. This is set at the factory.
- *Download System Log:* Consists of system log text files, which include a listing of system errors.
- *Download Calibration History:* Includes the data in the calibration history screen.
- *Download Configuration Data Backup to USB:* Allows the user to download the configuration file from the instrument to the USB.
- *Upload Configuration Data Restore from USB:* Allows the user to upload the configuration files from the USB to the instrument.
- *Restore:* Allows the user to upload the configuration files from the USB to the instrument.
- *Download All Data:* Downloads all reports, logs, histories, and backup information.

Use the following procedure to download data using the USB connection.

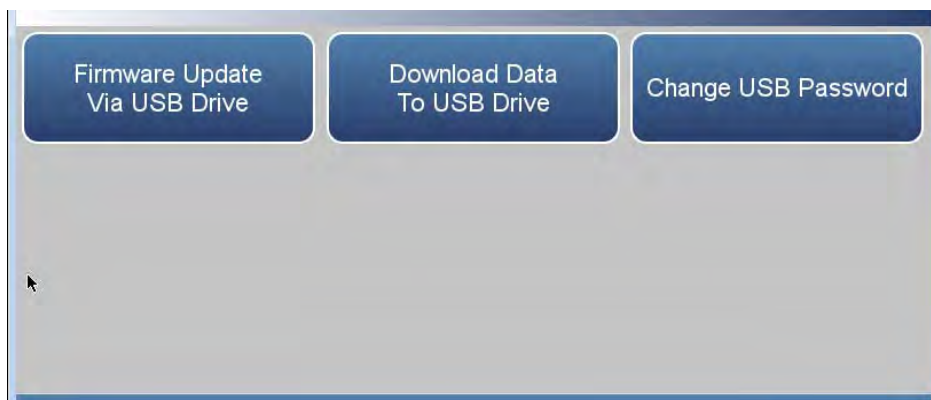
1. Plug a flash drive into the USB connection on the front of the instrument. If a USB password has been previously set, you will be prompted to enter the USB password to continue. Press **Enter** to continue.



2. To continue, select the **OK** button.



3. The USB Drive will display. Select **Download Data To USB Drive**.



4. The Download Data to USB Drive screen will display. Select from various options to download.



5. The instrument will display a “downloading data” message and begin transferring data to the USB drive.

**Note Do not remove the USB drive from the instrument while the data is downloading. ▲**

6. When the data download is complete, the instrument will display a “Success!” message and display the file name as it is stored on the USB flash drive. (The file name format is the instrument serial number, name of download, followed by a date/time stamp.) Remove the USB flash drive and select the OK button to continue.

## Change USB Password

The Change USB Password screen allows the user to set a new password for accessing USB.

### Home Screen>Settings>USB Drive>Change USB Password

To Change the USB Access Password perform the following steps using the graphical user interface only (do not use an external USB keyboard):

1. Enter the Current USB Access Password
2. Enter the New USB Access Password
3. Confirm the New USB Access Password
4. Commit the USB Access Password Change

Note: To clear the USB Password, follow the steps above using blank values for the New Password.

Continue

Cancel and Return  
to the Home Screen

### Home Screen>Settings>Security Access Levels>Change Standard Access Password>Continue

1. Enter the Current USB Access Password and then press Continue.  
If there is no Current USB Password then press Continue.

Enter Current  
USB Password

Continue

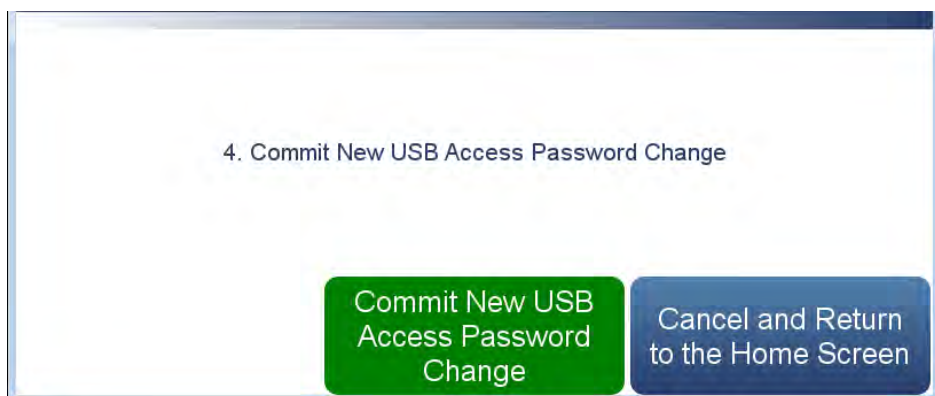
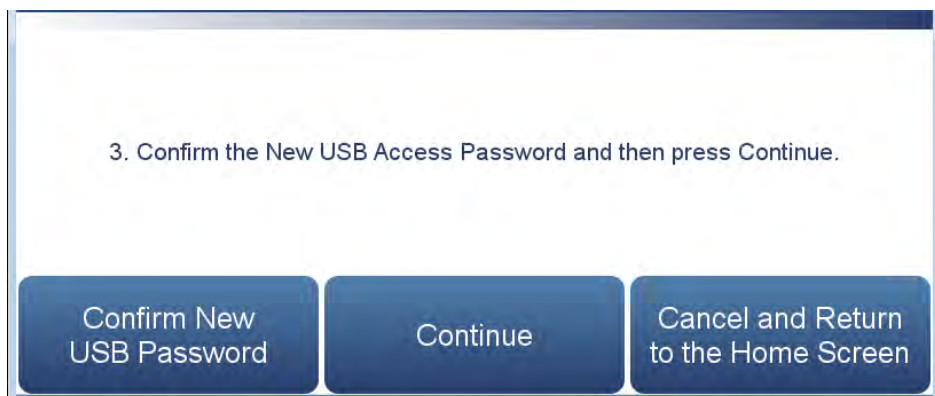
Cancel and Return  
to the Home Screen

2. Enter the New USB Access Password and then press Continue.

Enter New  
USB Password

Continue

Cancel and Return  
to the Home Screen



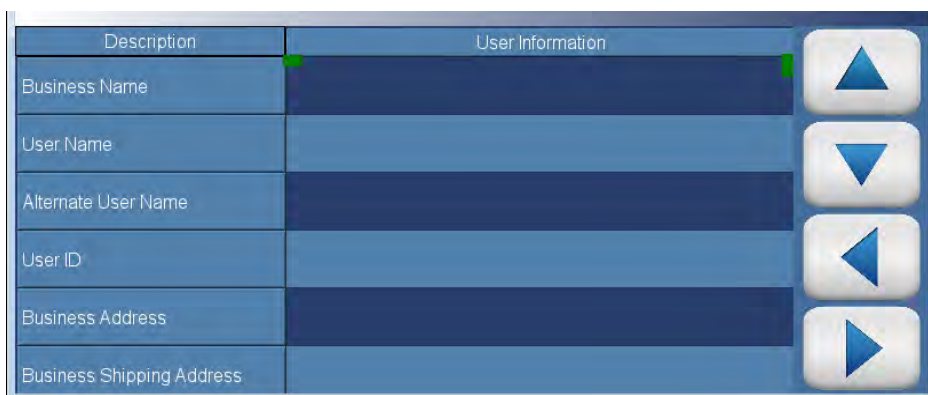
The Change USB Password screens contain the following information:

- *Enter Current USB Password:* User enters current USB password.
- *Continue:* Proceeds to next screen.
- *Enter New USB Password:* User enters new USB password.
- *Confirm New Security Access Password:* User confirms new security password for spelling confirmation.
- *Commit New USB Password Change:* Commits new USB password.
- *Cancel and Return to the Home Screen:* Exits screen and returns to the Home Screen without changing password.

## User Contact Information

The User Contact Information screen allows the user to enter their contact information. This is useful when contacting technical support through emails found at the screen Health Check>File Sharing and Support.

### Home Screen>Settings>User Contact Information



The screenshot shows a mobile application interface for 'User Contact Information'. It features a table with two columns: 'Description' and 'User Information'. The 'User Information' column is currently empty. To the right of the table are four navigation buttons: an up arrow, a down arrow, a left arrow, and a right arrow.

Description	User Information
Business Name	
User Name	
Alternate User Name	
User ID	
Business Address	
Business Shipping Address	

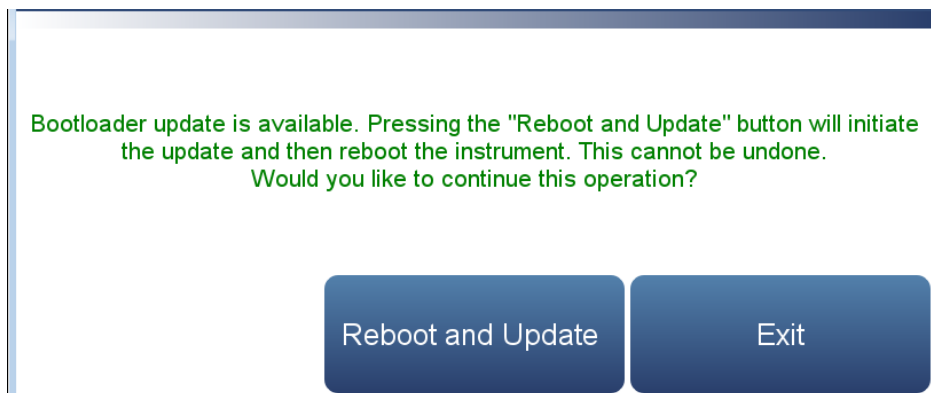
The User Contact Information screen contains the following information:

- Business Name
- User Name
- Alternate User Name
- User ID
- Business Address
- Business Shipping Address
- To: User Email Address
- CC: User Email Address 1–10
- User Phone Number
- Alternate User Phone Number
- Shelter / Lab Phone Number

## Update Bootloader

The Update Bootloader screen allows the user to update bootloader and reboot the instrument. If the button is blue, an update to the bootloader is available. If button is greyed out, no update is needed.

### Home Screen>Settings>Update Bootloader



The Update Bootloader screen contains the following information:

- *Reboot and Update:* Update bootloader and reboot instrument.
- *Exit:* Exits screen.





## Chapter 4

# Calibration

This chapter describes the procedures for calibrating the analyzer and describes the required equipment.

The 43iQ requires initial and periodic calibration according to the procedures described in this chapter. A quality control plan that allows the frequency and number of calibration points to be modified depending on calibration and zero/span check data should be implemented. Such a quality control program is essential to ascertain the accuracy and reliability of the air quality data collected. The data compiled for such a program might include items such as dates of calibration, atmospheric conditions, control settings and other pertinent data. For more detailed quality assurance guidelines, see the *Quality Assurance Handbook for Air Pollution Measurement Systems*, published by the U.S. EPA, Research Triangle Park, NC, 27711.

There are a number of conditions which should be met prior to a calibration or a zero/span check. First, the instrument should have at least 30 minutes to warm up and stabilize. Second, the range used during the calibration or zero/span check should be the same as that used during normal monitoring. Third, all operational adjustments to the instrument should be completed prior to calibration. Fourth, all parts of the gas flow system, such as sample lines, and particulate filters, which are used in normal monitoring should also be used during calibration. Finally, it is recommended that the recording devices and outputs used during normal monitoring be calibrated prior to the instrument calibration and that they be used during the calibration or the zero/span check.

## Equipment Required

The following equipment is required to calibrate the instrument:

- Zero air
- Calibration gas

**Note** In order to reduce the possibility of interferences during calibration, all zero gas supplied to the instrument during calibrations should use air as the zero gas and not nitrogen. The same recommendation also applies to span gases supplied, where the calibration gas is supplied with a known SO<sub>2</sub> concentration with the balance of gas as air and not nitrogen. ▲

## Zero Air Generation

An SO<sub>2</sub>-free (< 0.0005 ppb) air supply is required for the proper calibration and checkout of the instrument. There are several methods that are acceptable to generate this zero air.

## Commercial Heatless Air Dryers

Commercial heatless air dryers filled with a mixed bed of activated charcoal and a 13X molecular sieve have been found effective in removing SO<sub>2</sub> from compressed air. The use of this type of zero gas system is recommended when minimum maintenance is of prime importance. This system requires a source of compressed air. Refer to the manufacturer's recommendations for installation of such a system.

## Absorbing Column

An absorbing column packed with activated charcoal is acceptable for scrubbing SO<sub>2</sub> from ambient air. Ambient air is forced through a laboratory gas absorption column packed with the charcoal and the SO<sub>2</sub> is removed to acceptable levels (<0.0005 ppb). The charcoal should be changed at a minimum of every six months. It may be necessary to change the charcoal more frequently depending on local conditions.

## SO<sub>2</sub> Concentration Standard

A cylinder of SO<sub>2</sub> in air containing an appropriate concentration of SO<sub>2</sub> suitable for the selected operating range of the analyzer under calibration is necessary. The assay of the cylinder must be traceable either to a National Institute of Standards and Technology (NIST) SO<sub>2</sub> in Air Standard Reference Material (SRM) or an NIST/EPA approved gas manufacturer's Certified Reference Material (CRM).

A recommended protocol for certifying SO<sub>2</sub> gas cylinders against a SO<sub>2</sub>, SRM or CRM is given in the *Quality Assurance Handbook*<sup>1</sup>. The SO<sub>2</sub> gas cylinder should be recertified on a regular basis determined by the local quality control program.

## Calibration Gas Generation

A calibration gas system capable of providing accurate levels of SO<sub>2</sub> calibration gas between zero and 80% of the full-scale range is required. The calibration system must provide a flow rate of at least 0.5 LPM for an instrument with the standard flow (instruments with higher flow rates will require a higher minimum calibration system flow rate). All calibration gas should be derived from local or working standards (such as cylinders of compressed gas or permeation devices) that are certified as traceable to an NIST primary standard.

### Cylinder Gas Dilution

A cylinder gas dilution system, shown in Figure 4–1, can be constructed. All connections between components in the system should be made with glass, SS, PTFE or other non-reactive material.

The air flow controller should be capable of maintaining a constant air flow within  $\pm 2\%$  of the required flow rate. The SO<sub>2</sub> flow controller should be capable of maintaining constant SO<sub>2</sub> flows within  $\pm 2\%$  of the required flow rate. Ensure both flow controllers are properly calibrated. The pressure regulator for the standard SO<sub>2</sub> cylinder must have a non-reactive diaphragm and internal parts and a suitable delivery pressure.

### External Flow Meter(s) and Controller(s)

In order to obtain an accurate dilution ratio in the dilution method used for calibration, the flow rates must be regulated to 1%, and be measured to an accuracy of at least 2%. The meter and controller can be two separate devices, or combined in one device. The user's manual for the meter should be consulted for calibration information.

Additional information on the calibration of flow devices can be found in the *Quality Assurance Handbook*<sup>1</sup>. It should be noted that all flows should be corrected to 25 °C and 760 mmHg, and that care should be exercised in correcting for water vapor content.

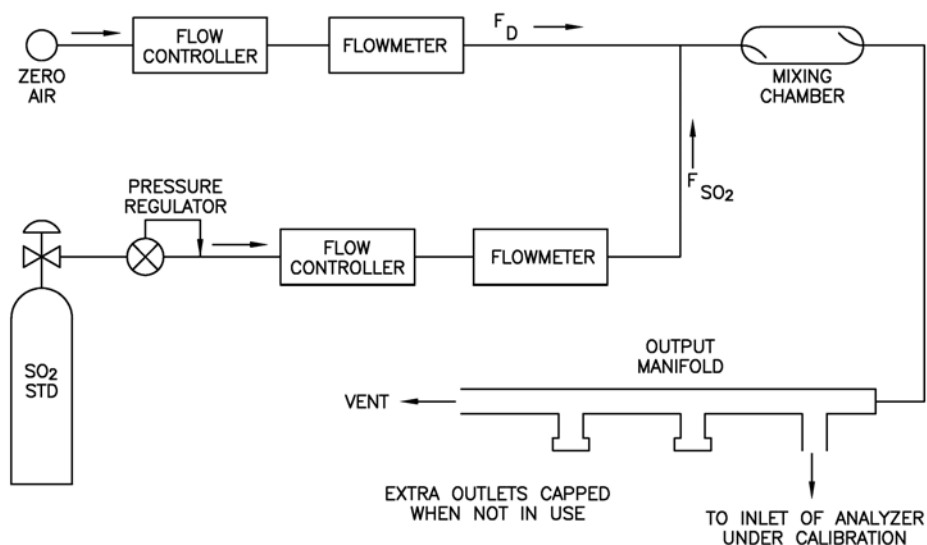


Figure 4–1. Cylinder Gas Dilution System

The exact SO<sub>2</sub> concentration is calculated from:

$$[SO_2]_{OUT} = \frac{[SO_2]_{STD} \times F_{SO_2}}{F_D + F_{SO_2}}$$

Where:

[SO<sub>2</sub>]<sub>OUT</sub> = diluted SO<sub>2</sub> concentration at the output manifold, ppm

[SO<sub>2</sub>]<sub>STD</sub> = concentration of the undiluted SO<sub>2</sub> standard, ppm

F<sub>SO<sub>2</sub></sub> = flow rate of the SO<sub>2</sub> standard corrected to 25 °C and 760 mm Hg

F<sub>D</sub> = flow rate of the dilution air corrected to 25 °C and 760 mm Hg

### **Commercial Precision Dilution Systems**

Commercial precision dilution systems are available which reliably and accurately dilute a high concentration gas mixture to provide a reliable span gas. A high concentration (50 ppm) of SO<sub>2</sub> in air is precisely diluted to the concentration range required.

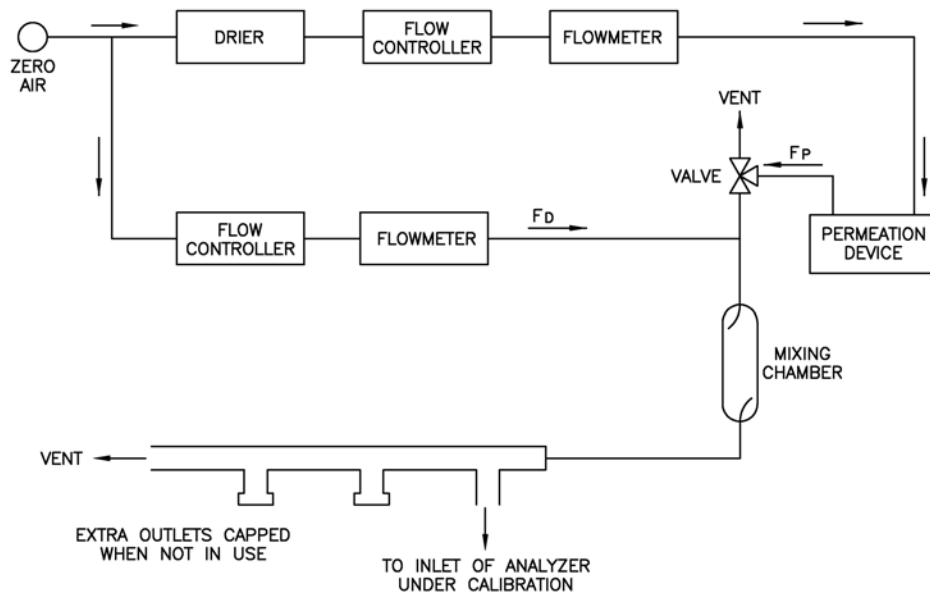
The Thermo Scientific 146iQ Multi-gas Calibrator is one such system for precision dilution.

### **Permeation Tube System**

Permeation tube systems which precisely maintain a set temperature to within ±0.1 °C and hold a zero air flow rate to within ±0.5% can be used for generation of span gas. The flow rate of the permeation system must be at least 0.5 LPM for proper operation.

A permeation tube system, shown in [Figure 4–2](#) can be constructed. All connections between components in the system should be made with glass, PTFE, or other non-reactive material.

The air flow controllers should be capable of maintaining a constant air flow within ±2% of the required flow rate. Ensure all devices are properly calibrated and that all flows are corrected to 25 °C and 1 atm.



**Figure 4–2.** Permeation Tube System

The SO<sub>2</sub> output level is calculated from:

$$[SO_2]_{OUT} = \frac{P \times K}{F_T}$$

Where:

[SO<sub>2</sub>]<sub>OUT</sub> = SO<sub>2</sub> output concentration in ppm

P = permeation rate in µg/min

F<sub>T</sub> = total flow rate of gas after mixing chamber (F<sub>P</sub> + F<sub>D</sub>) in liters/minute

K (SO<sub>2</sub>) = 0.382 constant for SO<sub>2</sub> permeant

### Commercial Permeation Systems

Commercial permeation systems, such as the Thermo Scientific 146iQ Multigas Calibration System, are available for this requirement. Refer to the instrument instruction manual for more information.

In addition to the 146iQ and other commercial permeation systems, the 43iQ can also be configured with an optional permeation oven to supply calibration gas for the instrument. The operation of the internal permeation oven is described in Chapter 9, “Optional Equipment”.

## Calibration

Regulations typically require zero/span calibration when the instrument is newly installed, moved, repaired, interrupted for more than a few days, or when span or zero shift by more than 15%.

All gas must be supplied to the instrument at atmospheric pressure. It may be necessary to employ an atmospheric bypass plumbing arrangement to accomplish this. Refer to [Figure 2–6](#) in the “[Installation and Setup](#)” chapter for an example of an atmospheric bypass plumbing arrangement.

If a filter is used, all gas must enter the instrument through the filter.

**Note** The calibration and calibration check duration times should be long enough to account for the transition (purge) process when switching from sample to zero and from zero to span. This transition time is the time required to purge the existing air. ▲

Depending on the plumbing configuration and the instrument, data from approximately the first minute of a zero calibration or check should be disregarded because of residual sample air. Also, data from approximately the first minute of a span calibration or check should be disregarded because the span is mixing with the residual zero air. ▲

Use the following procedure to perform a zero/span calibration.

1. If the instrument is equipped with the optional zero/span and sample valves, connect the zero and span gas to the rear panel bulkheads labeled ZERO IN and SPAN, otherwise connect a source of vented zero air to the SAMPLE bulkhead. The top right of the title bar indicates which mode is active: ZERO, SPAN, or SAMPLE.

**Note** Do not use nitrogen for zero air. ▲

2. To ensure that the zero air is being measured at atmospheric pressure, check that the zero air flow reported by the analyzer is approximately 0.5 LPM. Actual zero air flow should be 0.8 LPM or more, with the excess flowing out the atmospheric bypass.
  - a. From the Home screen choose **Settings>Health Check>Status and Alarms>Flow and Pressure**.
  - b. Make sure that the reported sample flow is less than the actual zero air flow.

3. Monitor the zero air reading and wait for the reading to stabilize.
4. From the Home Screen, press Calibration>**Calibrate Background**.  
The Target Concentration button will read 0.00. The Calculated Background button will display the background needed to make the current SO<sub>2</sub> concentration go to 0.00.
5. Press **Calibrate** to set the SO<sub>2</sub> reading to zero and to save the new background.
6. Connect a source of calibration gas to the SAMPLE bulkhead. The calibration gas concentration should be approximately 80% of the full-scale range.
7. To ensure that the calibration gas is being measured at atmospheric pressure, check that the sample flow in the analyzer is approximately 0.5 LPM. Actual sample air flow should be 0.8 LPM or more, with the excess flowing out the atmospheric bypass.
8. Sample the vented calibration gas and wait for the instrument reading to stabilize.
9. From the Home Screen, choose Calibration>**Calibrate Span Coefficient**.  
The user sets the span concentration by pressing the Edit Span Concentration button. The Calculated Span Coefficient button will show what the span coefficient will be set to if the Calibrate button is pressed. Pressing the Calibrate button will save the new coefficient and calibrate the instrument.
10. Enter the SO<sub>2</sub> calibration gas concentration using the pushbuttons, and then press **Calibrate** to calibrate the instrument to the SO<sub>2</sub> calibration gas.

**Note** The minimum and maximum analog output configuration values should be set to the default settings (minimum 0%; maximum 100%). ▲



## Calibration in Dual/Auto Range Mode

Regulations typically require zero/span calibration when the instrument is newly installed, moved, repaired, interrupted for more than a few days, or when span or zero shift by more than 15%.

All gas must be supplied to the instrument at atmospheric pressure. It may be necessary to employ an atmospheric bypass plumbing arrangement to accomplish this. Refer to [Figure 2–6](#) in the “[Installation and Setup](#)” chapter for an example of an atmospheric bypass plumbing arrangement.

If a filter is used, all gas must enter the instrument through the filter.

**Note** The calibration and calibration check duration times should be long enough to account for the transition (purge) process when switching from sample to zero and from zero to span. This transition time is the time required to purge the existing air. ▲

Depending on the plumbing configuration and the instrument, data from approximately the first minute of a zero calibration or check should be disregarded because of residual sample air. Also, data from approximately the first minute of a span calibration or check should be disregarded because the span is mixing with the residual zero air. ▲

Use the following procedure to perform a zero/span calibration.

1. If the instrument is equipped with the optional zero/span and sample valves, connect the zero and span gas to the rear panel bulkheads labeled ZERO IN and SPAN, otherwise connect a source of vented zero air to the SAMPLE bulkhead. The top right of the title bar indicates which mode is active: Zero, Span, or Sample.

**Note** Do not use nitrogen for zero air. ▲

2. To ensure that the zero air is being measured at atmospheric pressure, check that the zero air flow reported by the analyzer is approximately 0.5 LPM. Actual zero air flow should be 0.8 LPM or more, with the excess flowing out the atmospheric bypass.
  - a. From the Home screen choose **Settings>Health Check>Status and Alarms>Flow and Pressure**.
  - b. Make sure that the reported sample flow is less than the actual zero air flow.

3. Monitor the zero air reading and wait for the reading to stabilize.
4. From the Home Screen, choose **Calibration>Calibrate Background**.  
The Target Concentration button will read 0.000. The Calculated Background button will display the background needed to make the current SO<sub>2</sub> concentration go to zero.
5. Press **Calibrate** to set the SO<sub>2</sub> reading to zero and to save the new background.
6. Connect a source of calibration gas to the SAMPLE bulkhead. The calibration gas concentration should be approximately 80% of the high full-scale range.
7. To ensure that the calibration gas is being measured at atmospheric pressure, check that the sample flow in the analyzer is approximately 0.5 LPM. Actual sample air flow should be 0.8 LPM or more, with the excess flowing out the atmospheric bypass.
8. Sample the vented calibration gas and wait for the instrument reading to stabilize.
9. From the Home Screen, choose **Calibration>Calibrate High Range Span Coefficient**.  
The user sets the span concentration by pressing the Edit High Range Span Concentration button. The Calculated High Span Coefficient button will show what the high range span coefficient will be set to if the Calibrate button is pressed. Pressing the Calibrate button will save the new high range coefficient and calibrate the instrument.
10. Enter the SO<sub>2</sub> calibration gas concentration using the pushbuttons, and then press **Calibrate** to calibrate the instrument to the high SO<sub>2</sub> calibration gas.

**Note** The minimum and maximum analog output configuration values should be set to the default settings (minimum 0%; maximum 100%). ▲

11. Connect a source of calibration gas to the SAMPLE bulkhead. The calibration gas concentration should be approximately 80% of the low full-scale range.

12. From the Home Screen, choose **Calibration>Calibrate Low Range Span Coefficient**.

The user sets the span concentration by pressing the Edit Low range Span Concentration button. The Calculated Low Range Span Coefficient button will show what the low span coefficient will be set to if the Calibrate button is pressed. Pressing the Calibrate button will save the new low range coefficient and calibrate the instrument.

13. Enter the SO<sub>2</sub> calibration gas concentration using the pushbuttons, and then press **Calibrate** to calibrate the instrument to the low range SO<sub>2</sub> calibration gas.

## Zero and Span Check

The zero and span check procedure is normally performed any time a quick check of the accuracy of the instrument is required. Normally, zero and span are checked daily. As experience is gained with the instrument, the frequency of these checks can be adjusted accordingly.

The span gas concentration used in the span check should be between 70% and 90% of the full-scale range. The zero and span drift should be measured and recorded prior to making any adjustments.

All gas must be supplied to the instrument at atmospheric pressure. It will be necessary to employ an atmospheric bypass plumbing arrangement to accomplish this.

If a filter is used, all gas must enter the instrument through the filter.

Use the following procedure to check the zero/span.

1. If the instrument is equipped with the optional zero/span and sample valves, connect the zero and span gas to the rear panel bulkheads labeled ZERO IN and SPAN, otherwise connect a source of vented zero air to the SAMPLE bulkhead.

**Note** Do not use nitrogen for zero air. ▲

2. To ensure that the zero air is being measured at atmospheric pressure, check that the zero air flow reported by the analyzer is approximately 0.5 LPM. Actual zero air flow should be 0.8 LPM or more, with the excess flowing out the atmospheric bypass.
  - a. From the Home screen choose **Settings>Health Check>Status and Alarms>Flow and Pressure**.

- b. Make sure that the reported sample flow is less than the actual zero air flow.
3. Monitor the zero air reading and wait for the reading to stabilize.
4. Record the measured SO<sub>2</sub> value as the zero drift since the last adjustment. If the zero has changed by more than  $\pm 0.015$  ppm, it is recommended that a new calibration be performed.
5. Connect a source of vented span gas to the SAMPLE bulkhead. The span gas should be approximately 80% of the full-scale range.
6. To ensure that the span gas is being measured at atmospheric pressure check that the flow is approximately 0.5 LPM or more, with the excess flowing out the atmospheric bypass.
7. Sample the vented calibration gas and wait for the instrument reading to stabilize.
8. Record the difference between the measured SO<sub>2</sub> value and the actual SO<sub>2</sub> span concentration used. This is the span drift since the last adjustment. If the calibration has changed by more than  $\pm 10\%$ , a new calibration should be performed.

## Manual Calibration

The Manual Calibration screen allows the user to view and manually adjust the zero background and span coefficient. These are used to correct the SO<sub>2</sub> readings that the instrument generates using its own internal calibration data.

Normally, the zero background and span coefficient are calculated automatically at the Calibrate Background and Calibrate Span Coefficient described earlier in the chapter. However, the calibration factors can also be set manually using the functions as described below.

The following screen is shown in single range mode. In dual or auto range modes, “High Range” or “Low Range” buttons are displayed to indicate the calibration of the high or low coefficient. The Adjust High Range Span Coefficient and Adjust Low Range Span Coefficient screens function the same way.

**Home Screen>Calibration>Advanced Calibration>Manual Calibration  
(single range mode)**



## Adjust Background

The SO<sub>2</sub> background is the amount of signal read by the analyzer while sampling zero air.

The Adjust Background screen is used to perform a manual zero background calibration of the instrument. As such, the instrument should sample zero air until stable readings are obtained. The button labeled Adjust Background allows the user to change zero background. The second button called Adjusted Concentration shows what the new SO<sub>2</sub> concentration would be based on the changed zero background. Press the Calibrate button to save the adjusted zero background value.

**Home Screen>Calibration>Advanced Calibration>Manual  
Calibration>Adjust Background**



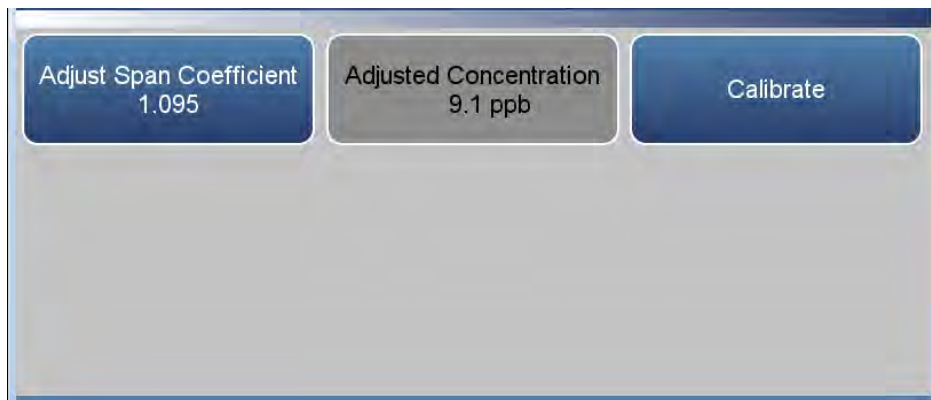
## Adjust Span Coefficient

The span coefficient is used to correct the SO<sub>2</sub> readings and normally has a value near 1.000 with minimum/maximum limits of 0.500 and 2.000 respectively.

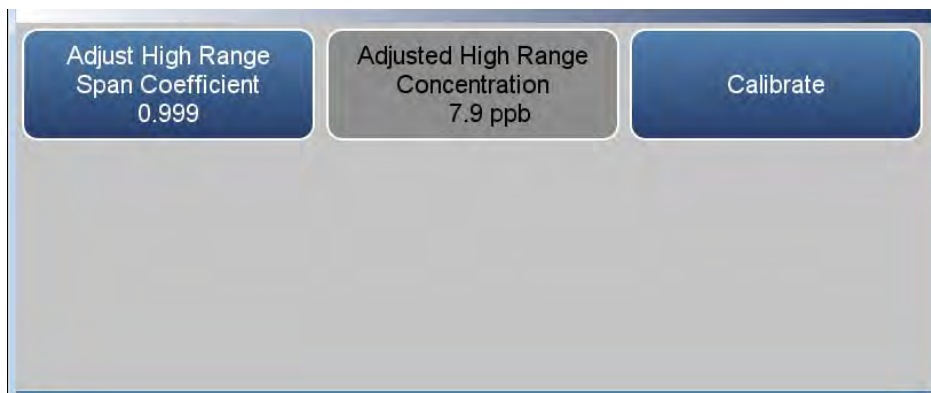
The user can manually change the span coefficient by entering a value in the Adjust Span Concentration button. The second button called Adjusted

Concentration shows what the new SO<sub>2</sub> concentration would be based on the adjusted span coefficient. Press the Calibrate button to save the adjusted span coefficient value.

**Home Screen>Calibration>Advanced>Manual Calibration>Adjust Span Coefficient (single range mode)**



**Home Screen>Calibration>Advanced Calibration>Manual Calibration>Adjust High Range Span Coefficient (dual or auto range mode)**



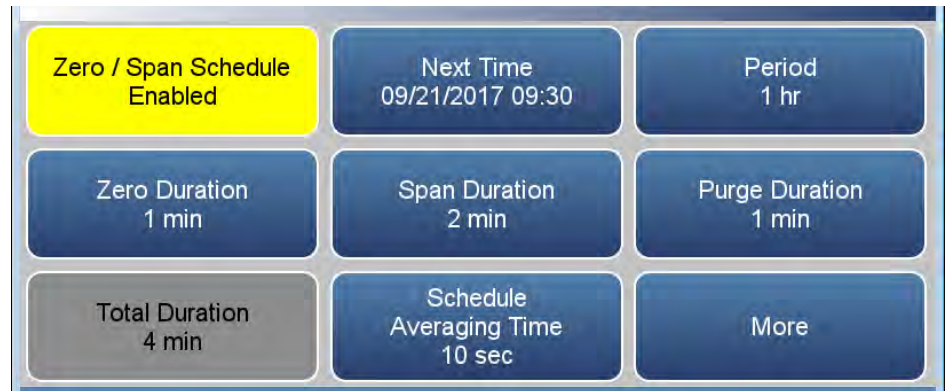
**Reset Bkg to 0.000  
and Span Coef to  
1.000**

The Reset Bkg to 0.000 and Span Coef to 1.000 screen allows the user to reset the calibration configuration values to factory defaults.

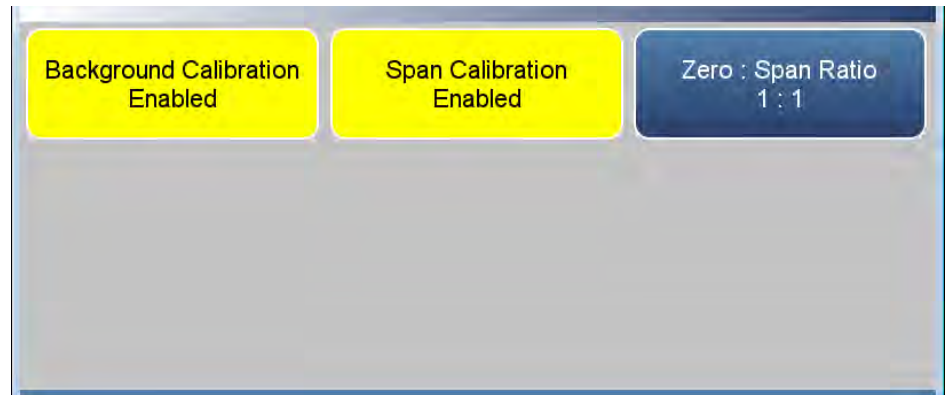
## Zero/Span Schedule

The Zero/Span Schedule screen is available only if the zero/span valve option is installed and turned on (toggles enabled or disabled) at the screen Settings>Configuration. It is used to program the instrument to perform fully automated zero and span calibration or calibration checks.

### Home Screen>Calibration>Zero/Span Schedule



### Home Screen>Calibration>Zero/Span Schedule>More



### Next Time

The Next Time button is used to view and set the initial date and time (24-hour format) of the zero/span schedule. Once the zero/span schedule begins, the date and time of the next zero/span schedule is calculated and displayed.

### Period

The Period button defines the period or interval between zero/span schedule. Periods between 0 and 999 hours are acceptable. To turn the zero/span schedule off, set the period to 0.

### Zero/Span/Purge Duration Minutes

The Zero Duration button defines how long zero air is sampled by the instrument. The Span and Purge Duration buttons look and function the

same way as the zero duration button. The span duration button is used to set how long the span gas is sampled by the instrument. The purge duration button is used to set how long the purge period will be after doing a zero and/or span. This gives the instrument time to flush out the zero and span gas before any meaningful sample data is taken. Logged data is flagged as taken during a purge to show that the data is suspect. Durations between 0 and 99 minutes are acceptable. Each time a zero/span schedule occurs the zero is done first, followed by the span. To perform just a zero, set the span duration to 0 (off). The same applies to perform just a span.

## Schedule Averaging Time

The Schedule Averaging Time button allows the user to adjust the schedule averaging time. The schedule averaging time is used by the analyzer only when performing a zero/span schedule. The analyzer's averaging time is used for all other functions. Range is 1–300 seconds.

## Background Calibration and Span Calibration

Background Calibration and Span Calibration are toggle buttons that change between enabled or disabled.

If the background calibration is set to enabled, then a zero adjustment is made. If the span calibration is set to enabled, then a span adjustment is made. (This is how to set up a scheduled, recurring auto calibration.)

## Zero/Span Ratio

The Zero/Span Ratio button is used to set the ratio of zero checks or adjustments to span checks or adjustments. For example, if this value is set to 1, a span duration will follow every zero duration. If this value is set to 3, there will be two zero checks between each span check. This value may be set from 1 to 99, with 1 as default.

## References

1. Section 12 of EPA *Quality Assurance Handbook for Air Pollution Measurement Systems*, Volume II, available at [www.epa.gov](http://www.epa.gov).

Section 12 also provides information on “Calibration of Primary and Secondary Standards for Flow Measurements”.

Specific information on certification of concentration standards is given in EPA *Traceability Protocol for Assay and Certification of Gaseous Calibration Standards*, available at [www.epa.gov](http://www.epa.gov).





## Chapter 5

# Maintenance

This chapter describes the periodic maintenance procedures that should be performed on the instrument to ensure proper operation. Since usage and environmental conditions vary greatly, you should inspect the components frequently until an appropriate maintenance schedule is determined.

### Safety Precautions



Read the safety precautions before beginning any procedures in this chapter.

**Equipment Damage** Some internal components can be damaged by small amounts of static electricity. A properly grounded antistatic wrist strap must be worn while handling any internal component. For more information about appropriate safety precautions, see the “Servicing” chapter. ▲

### Fan Filter Inspection and Cleaning

Use the following procedure to inspect and clean the fan filter.

1. Remove the fan guard from the fan and remove the filter.
2. Flush the filter with warm water and let dry (a clean, oil-free purge will help the drying process) or blow the filter clean with compressed air.
3. Re-install the filter and fan guard.

## Pump Rebuilding

Use the following procedure to rebuild the pump.

Equipment required:

Pump rebuild kit (qty. 1)

Phillips drive, #1 or Torque drive, T10 (depending on pump version)

Pencil or marker



**Figure 5–1.** Single Stage Pump

1. Turn instrument OFF, unplug the power cord, and remove the cover.
2. Mark the position of head parts relative to each other by drawing a line with a pencil. This helps avoid incorrect assembly later.
3. Undo the four screws in the head.
4. Lift the head plate and the intermediate plate off the housing.
5. Hold the pump with one hand, so that the diaphragm is pointing downwards. Lift the diaphragm by the opposing side edges, grasp it and unscrew it in the counter-clockwise direction.

6. Remove connection rod disc and diaphragm spacers from the threaded pin of the diaphragm.
7. Push the connection rod disc and the diaphragm spacers in this order onto the threaded pin of the new diaphragm.
8. Move the connecting rod to the upper point.
9. Screw the new diaphragm with connection rod disc and spacers clockwise onto the connection rod and tighten hand-tight.
10. Place the intermediate plate on housing, in the position indicated by the drawing line.
11. Place the new valve plate on the intermediate plate.
12. Place the head plate on the intermediate plate, in the position indicated by the drawing line; gently tighten the four screws, evenly and diagonally (if a torque screwdriver is available: torque about 0.30 Nm).
13. Let the pump run.

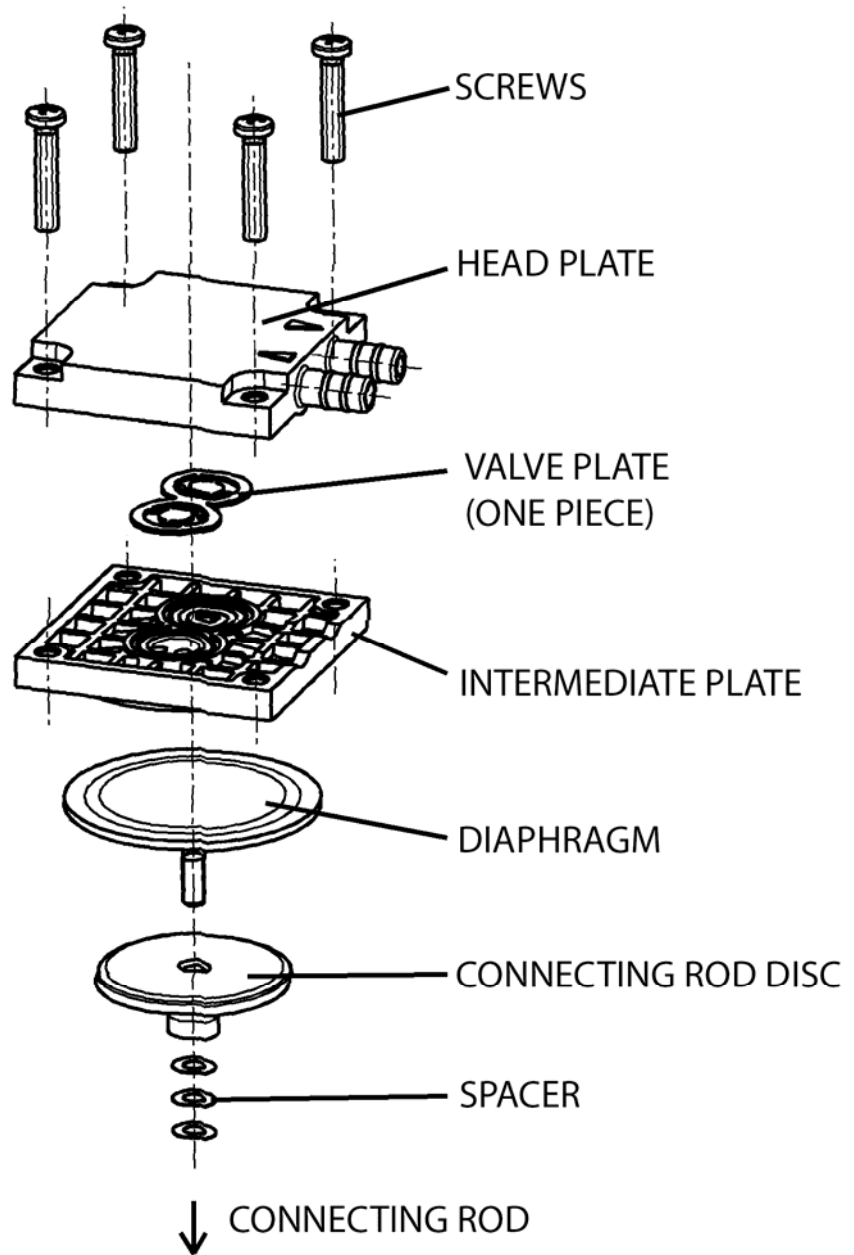


Figure 5-2. Pump Rebuilding

## Leak Test

Use the following procedure to perform a leak test.

Equipment Required:

Cap

Vacuum Tester with Gauge (with a resolution of .5 in Hg or better)

1. Turn instrument OFF, unplug the power cord.
2. Block the SAMPLE bulkhead on the rear panel with a leak-tight cap.
3. Connect the vacuum tester tool to the EXHAUST bulkhead on the rear panel.
4. Squeeze trigger until gauge reads to pull in 10 in Hg.
5. Observe vacuum gauge for stable reading for 5 minutes. If reading remains at 10 in Hg, no leak is present.

**Note** Acceptable leak rate is .5 in Hg over 10 minutes. ▲

## Lamp Voltage Check

The instrument is equipped with a lamp voltage control circuit, which automatically corrects for degradation of the flash lamp. However, after several years of use, the lamp may have degraded to the point that is being driven with the maximum voltage that the power supply can deliver.

There are two methods available that allows the operator to check the lamp voltage. The first is via the Measurements Settings>Advanced Measurement Settings>Optical Bench Settings>**Continue to Detector Gain Settings** Screen. The current Lamp Voltage and Lamp Intensity are displayed.

The second method is via Settings>Health Check>Status and Alarms>**SO2 Bench** screen. The current Lamp Voltage and Lamp Intensity are displayed along with the upper and lower alarm limits.

For detailed information about this screen, refer to the “[Operation](#)” chapter. For more information about replacing the lamp or adjusting the lamp voltage control circuit, see the “[Servicing](#)” chapter.

## Lamp Voltage Adjustment

The auto calibration of the detector will automatically adjust the lamp voltage to 800 volts ( $\pm 5$  Volts). This is done so by adjusting the gain on the detector to optimize the illumination of the lamp.

Use the following procedure to adjust the lamp voltage.

1. From the Home screen choose Settings>Measurement Settings>Advanced Measurement Settings>Optical Bench Settings>**Continue To Detector Gain Settings Screen**.
2. Under the Detector Gain – Auto Cal, Press “Start” to initiate the auto calibration sequence.

Description	Detector Gain	Lamp Voltage	Lamp Intensity	
Manual Entry	39	0.4	0.0	▲
Auto Cal	Start			▼
End Cal	Stop			◀
Default Values	Default Gain			▶

3. To manually adjust the detector gain, touch the numeral value under the detector gain. Then change the Manual Entry Detector Gain to your set value and save.







# Chapter 6

## Troubleshooting

This chapter presents guidelines for diagnosing analyzer failures, isolating faults, and includes recommended actions for restoring proper operation.

### Safety Precautions

Read the safety precautions in Appendix A, “[Safety](#)” before performing any actions listed in this chapter.

### Troubleshooting Guide

[Table 6–1](#) provides general troubleshooting information for the common platform and indicates the checks that you should perform if you experience an instrument problem. It also lists 43iQ specific troubleshooting information and alarm messages you may see on the graphics display and provides recommendations about how to resolve the alarm condition.

**Table 6–1.** 43iQ Troubleshooting Guide

Problem	Possible Cause	Action
Instrument does not start (LEDs on front panel do not come on and display is blank)	No power	Verify that the power cord is plugged in, power is available and that it matches the voltage and frequency configuration of the instrument.
	Fuse is blown or missing	Disconnect power and check fuses with a volt meter.
	Bad switch or wiring connection to switch	Check for 24V @ J9 on the Backplane board (middle pins). Check all wiring connections.
Front panel display does not start (LEDs on front panel are off)	Disconnected ribbon cable	Power down and evaluate connections of display ribbon cable.
Front panel display does not start (LEDs on front panel are on)	Defective Display	Connect to the instrument using ePort. Select “Remote Interface”. If normal GUI is displayed, replace defective display.
Front panel display stays white after power up (LEDs on front panel are on)	Unseated or missing Micro SD card	Power off, re-seat Micro SD or install if missing.

<b>Problem</b>	<b>Possible Cause</b>	<b>Action</b>
	Micro SD Card Programming	If Micro SD card was just replaced, re-install the old one. If the problem is fixed, request a replacement Micro SD card.
Solenoid current out of range (option)	Sticking or damaged solenoid	Reset solenoid via Settings>Health Check>Status and Alarms>Valve and Pump Resets screen. If damaged, replace solenoid valve block.
Pump current out of range	Damaged or dirty pump	Reset pump via Settings>Health Check>Status and Alarms>Valve and Pump Resets. Inspect and refurbish pump. If pump motor is damaged, replace pump.
Cannot zero instrument or there is a high background signal when sampling zero air. (Zero air should produce a reading equivalent to less than 15 ppb SO <sub>2</sub> .)	Zero air system is faulty, needs new SO <sub>2</sub> scrubbers or requires maintenance.	Test against an ultra-zero cylinder from a reputable scientific gas supplier or check effect of a new chromatography grade activated charcoal scrubber installed at the instrument inlet.
	Zero air flow rate is inadequate	Check by-pass or atmospheric pressure vent to verify that the zero air system is providing more flow than the instrument is drawing.
	Instrument is not drawing in zero air	Check the sample flow and pressure in the Settings>Health Check>Status and Alarms>Flow and Pressure screen.  Use an independent flow meter to check flows at the sample inlet and exhaust bulkheads (they should match).  Perform a leak test as described on page 5-5.
	Span gas containing SO <sub>2</sub> , NO or hydrocarbon is contaminating system	Verify that span gases connected to the calibration system are shut off and leak-tight.
	Internal or external lines, filters and other sample handling equipment are contaminated or dirty	Replace inlet filter (if installed) and as much as possible.
	Hydrocarbon kicker has failed	Replace the hydrocarbon kicker.
	High scattered light	Toggle the "Flash Lamp" off in the Settings>Measurement

Problem	Possible Cause	Action
		Settings>Advanced Settings>Flash Lamp screen. If the previously high signal drops to zero or less when the flash lamp is off, the problem may be caused by scattered light from dust in the optical bench. If so, carefully clean the bench.
Instrument appears to zero, but there is weak or no response to span gas	Span cylinder empty	Check the source pressure.
	Calibration system failure	Check solenoids or other hardware to be sure that span gas is being delivered.
	Flow rate of the diluted span mix is adequate	Check by-pass or atmospheric vent to verify that the zero air system is providing more flow than the instrument draws.
	Instrument is not drawing in span gas	Check the sample flow and pressure in the Settings>Health Check>Status and Alarms>Flow and Pressure screen.  Use an independent flow meter to check flows at the sample inlet and exhaust bulkheads (they should match).  Perform a leak test as described on page 5-5.
	SO <sub>2</sub> is being absorbed by tubing, filters or dirt in the calibration system	Replace any lines made of vinyl or plastics with fresh PTFE or stainless steel. Replace PTFE filter membranes that look dirty. Remove any filters that are not PTFE membranes.
	Flash lamp has failed	Listen for the rapid clicking of the flash lamp. Check the flash lamp voltage and intensity.
	PMT has failed	Check the PMT voltage and run the optical span test. A good optical span test indicates that the PMT is OK and that the problem is more likely the lamp. Adjust PMT voltage if needed.
Zero or Span will not stabilize	Flow rate of the diluted span mix is inadequate	Check the by-pass or atmospheric pressure vent to verify that the zero air system is providing more flow than the instrument is

<b>Problem</b>	<b>Possible Cause</b>	<b>Action</b>
		drawing.
	Instrument is not drawing in span gas	<p>Check the sample flow and pressure in the Settings&gt;Health Check&gt;Status and Alarms&gt;Flow and Pressure screen.</p> <p>Use an independent flow meter to check flows at the sample inlet and exhaust bulkheads (they should match).</p> <p>Perform a leak test as described on page 5-5.</p>
	SO <sub>2</sub> is being absorbed and released by dirt in tubing or filters of the calibration system or contamination inside the instrument	<p>Replace any lines made of vinyl or plastics with fresh PTFE or stainless steel. Replace PTFE filter membranes that look dirty.</p> <p>Remove any filters that are not PTFE membranes.</p>
	Averaging time is not correct	<p>Check the "Averaging Time" in the Settings&gt;Measurement Settings screen. If too high, the unit will be slow to stabilize. If too low, the signal may appear to be noisy.</p>
	Flasher lamp	<p>Replace with known-good lamp to see if the lamp is the problem.</p>
Reduced response or no response to sample gas with alarm(s) indicated	Undefined electronic failure or pump failure	<p>Check the status and alarms screen to localize fault.</p> <p>Check the response to known span gas.</p> <p>Run an optical span test.</p>
	Instrument is not drawing in sample as expected	<p>Check the sample flow and pressure in the Settings&gt;Health Check&gt;Status and Alarms&gt;Flow and Pressure screen.</p> <p>Use an independent flow meter to check flows at the sample inlet and exhaust bulkheads (they should match).</p> <p>Perform a leak test as described on page 5-5.</p>
Reduced response or no response to sample gas with no alarm(s) indicated	Instrument is not properly calibrated	<p>Verify the SO<sub>2</sub> background and SO<sub>2</sub> coefficient are set appropriately in the Calibration screen.</p>

<b>Problem</b>	<b>Possible Cause</b>	<b>Action</b>
	Instrument is not drawing in sample as expected	<p>Check sample flow and pressure readings in the Settings&gt;Health Check&gt;Status and Alarms&gt;Flow and Pressure screen.</p> <p>Use an independent flow meter to check flows at the sample inlet and exhaust bulkheads (they should match).</p> <p>Perform a leak test as described on page 5-5.</p> <p>Check the external plumbing for leaks or other problems.</p> <p>Check all external plumbing and the source of the sample to verify that the SO<sub>2</sub> is not being absorbed by the sampling system. Lines carrying SO<sub>2</sub> must be made from clean PTFE or stainless steel.</p>
	Detection circuit failure	Run the optical span test to verify PMT and associated electronics.
	PMT failure	Check the PMT voltage. Adjust if needed.
	Flash lamp failure	Check the lamp voltage. Perform a detector Autocal. If outside of spec, replace the detector.
Span calibration coefficient outside acceptable limits of 0.5–2.0.	Bad span gas	Verify quality of span gas.
	System leak	Perform a leak test as described on page 5-5.
	Insufficient calibrator flow	Verify calibrator is providing a flow of at least 0.8 LPM.
Excessive noise or spikes on analog outputs	Defective or low sensitivity	Check PMT voltage and run an optical span test. Replace PMT with known-good unit if possible.
	Noise pick-up by recorder or data logger	<p>Check analog cable shielding and replace.</p> <p>Try to localize source of noise by comparing analog signal to data collected through RS-232 or Ethernet.</p>
Poor linearity	Problem with calibrator	Verify accuracy of the calibration system with an independent flow meter.

<b>Problem</b>	<b>Possible Cause</b>	<b>Action</b>
	Hydrocarbon kicker	Replace kicker if older than 3 years.
	Leak in sample probe line	Check for variable dilution.
Excessive response time	Averaging time is not set correctly	Check the "Averaging Time" in the Settings>Measurement Settings screen.
	Instrument is not drawing in sample at the expected flow rate	Check sample flow and pressure readings in the Settings>Health Check>Status and Alarms>Flow and Pressure screen.  Use an independent flow meter to check flows at the sample inlet and exhaust bulkheads (they should match).  Perform a leak test as described on page 5-5.
	SO <sub>2</sub> is being absorbed and released by dirt in tubing or filters of the calibration system or contamination inside the instrument	Replace any lines made of vinyl or plastics with fresh PTFE or stainless steel.
	Contaminated bench	Replace PTFE filter membranes that look dirty.  Remove any filters that are not PTFE membranes.
Analog signal doesn't match expected value	Software has not been configured	Contact technical support for additional information and options.
	Analog output goes above full-scale value or below zero	Verify that the selected analog output has been properly configured to match the data system.  By default, a 5% over and under range on the analog outputs is provided. If this is not desirable due to system restrictions, it may be turned off in the Settings>Communications>Analog I/O screen.
	Recorder is drawing down output	Verify that the recorder or data logger input impedance meets minimum requirements.
Flow meter fluctuations	Dirty pump diaphragm	Clean or replace pump diaphragm.

<b>Problem</b>	<b>Possible Cause</b>	<b>Action</b>
	Capillary blocked	Clean or replace capillary.
	Clogged PTFE line	Inspect all sample lines.
Alarm – Chamber Temperature	Heater failed	Replace heaters as needed.
	Defective PCB	Replace PCB.
Alarm – Perm Gas Temp	Incorrect Perm oven set temperature or alarm setting	Check that the alarm settings match the set temperature.
	Perm oven heater thermistor or gas thermistor error	Replace thermistor.
	Perm oven failure	Replace the Perm oven.
Alarm – Pressure	High pressure indication	Check plumbing for leaks.
		Check the pump for a tear in the diaphragm. Replace if needed.
		Check that the capillary is properly installed and o-rings are in good shape.
Alarm – Flow	Flow low	Check sample capillary for blockage. Replace as necessary.
		If using sample particulate filter, make sure it is not blocked. Disconnect sample particulate filter from the sample bulkhead. If flow increases, replace the filter. Perform a leak test as described on page 5-5.
	Flow high	When delivering zero air or gas to the instrument, use an atmospheric dump.
	Flow = 0 LPM	Check that Step POL board #1 has both dip switch settings of SW2 off (both facing the rear of the instrument). Verify the pump is plugged into the Step POL board.
	Worn Diaphragm	Rebuild pump every 12 months or as needed.
Alarm – Intensity	Low – Lamp is failing	Check that the lamp and trigger pack are securely fastened.
		Replace lamp.
Alarm – Lamp voltage	Low voltage (<750v)	Replace lamp power supply.
	High voltage (>1200v)	Replace flash lamp.



<b>Problem</b>	<b>Possible Cause</b>	<b>Action</b>
Alarm – SO <sub>2</sub> Conc.	Concentration has exceeded range limit	Check to ensure range corresponds with expected value. If not, select proper range.
	Concentration low	Check user-defined low set point. Be sure the minimum trigger is set as desired.
Alarm – Board Communication	Cable connection	Check that DMC cable is connected properly. Reseat if needed.
	Defective DMC PCB	Replace DMC board.
Alarm – Power Supply	Cable connection	Check that DMC cable is connected properly. Reseat if needed.
	Defective component	Check for other alarms, as it is possible that another component of that DMC is drawing too much current.
	Defective DMC PCB	Replace DMC board.
Alarm – Module Temperature	Cable connection	Check that DMC cable is connected properly. Reseat if needed.
	Other alarm	Make sure the instrument temperature is not too high or in alarm.
	Defective DMC PCB	Replace DMC board.
Alarm – 5V/24V Step Board	Cable connection	Check the cable connections to that Step POL board.
Alarm – Internal Temperature	Fan failure	Replace fan if not operating properly..
	Dirty fan filter	Clean or replace filter.
	Overheating PCB	Locate defective PCB reporting the error and replace if needed.
Alarm – Analog I/O	Defective PCB	Replace Analog board.
Alarm – Digital I/O	Defective PCB	Replace Digital board.
Alarm – Auto Bkg Cal/Check	Incorrect high alarm limit	Verify the high limit is correct via Settings>Status and Alarms>Concentrations screen.
	Instrument background calibration failed	Recalibrate the instrument.
Alarm – Auto Span Cal/Check	Incorrect high alarm limit	Verify the high limit is correct via Settings>Status and Alarms>Concentrations screen.

<b>Problem</b>	<b>Possible Cause</b>	<b>Action</b>
	Instrument span calibration failed	Recalibrate the instrument.

---



# Chapter 7

## Servicing

This chapter describes the periodic servicing procedures that should be performed on the instrument to ensure proper operation and explains how to replace the 43iQ subassemblies.

### Safety Precautions

Read the safety precautions before beginning any procedures in this chapter.



The service procedures in this manual are restricted to qualified service representatives. ▲



If the equipment is operated in a manner not specified by the manufacturer, the protection provided by the equipment may be impaired. ▲



**CAUTION** If the LCD panel breaks, do not let the liquid crystal contact your skin or clothes. If the liquid crystal contacts your skin or clothes, wash immediately using soap and water. ▲

Do not remove the LCD panel or frame from the LCD module. ▲

The LCD polarizing plate is very fragile, handle it carefully. ▲

Do not wipe the LCD polarizing plate with a dry cloth, as it may easily scratch the plate. ▲

Do not use alcohol, acetone, MEK or other Ketone based or aromatic solvents to clean the LCD module, but rather use a soft cloth moistened with a naphtha cleaning solvent. ▲

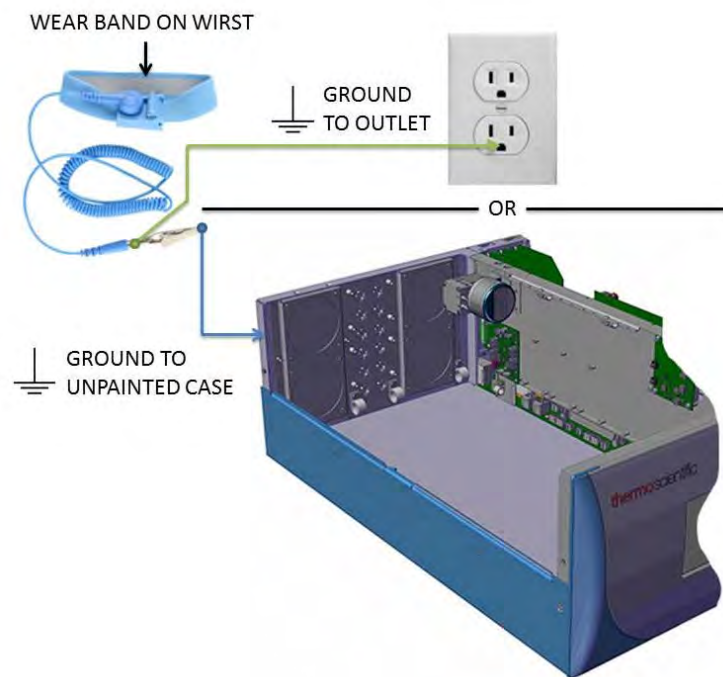
Do not place the LCD module near organic solvents or corrosive gases. ▲

Do not shake or jolt the LCD module. ▲



**Equipment Damage** Some internal components can be damaged by small amounts of static electricity. A properly grounded antistatic wrist strap must be worn while handling any internal component. For more information about appropriate safety precautions, see “[Safety](#)”. ▲

**Note** If an antistatic wrist strap is not available, be sure to touch the instrument chassis before touching any internal components. When the instrument is unplugged, the chassis is not at earth ground. ▲



**Figure 7–1.** Properly Grounded Antistatic Wrist Strap

**Note** Ground to unpainted case or outlet as shown. ▲

## **Firmware Updates**

New versions of the instrument software are periodically made available over Ethernet, USB flash drive, or company website at:

[www.thermofisher.com](http://www.thermofisher.com)

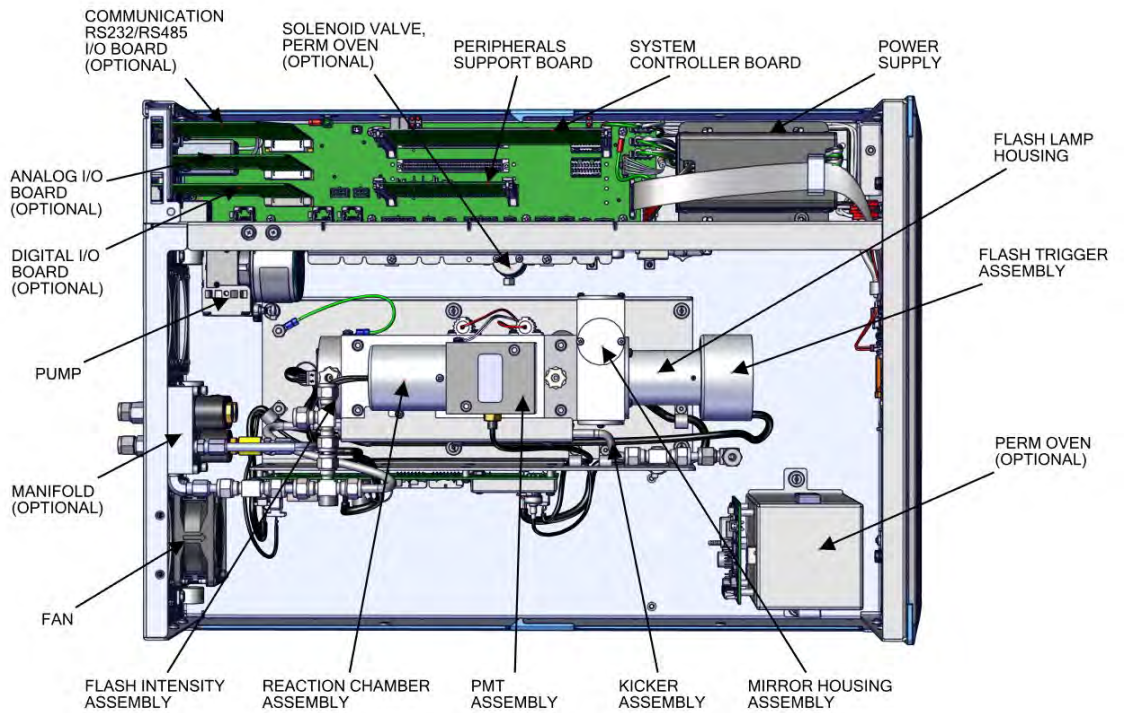
For more information on installing new firmware, see “Installing New Firmware” in the *iQ Series Communications* manual.

## **Replacement Parts List**

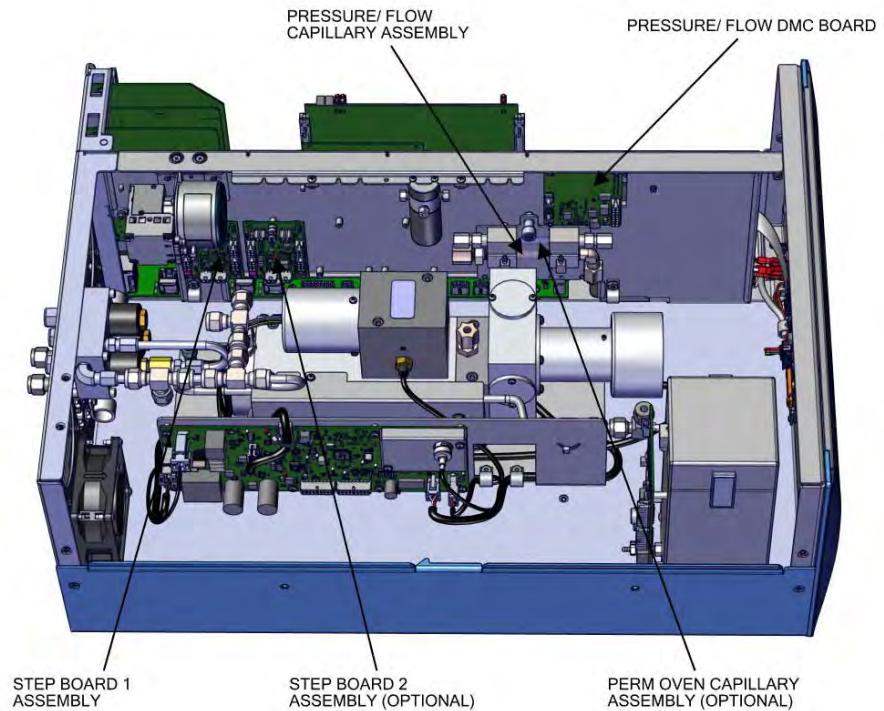
For a complete list of spare parts, visit the company website at:

[www.thermofisher.com/43iQ](http://www.thermofisher.com/43iQ)

Refer to [Figure 7–2](#) and [Figure 7–3](#) to identify the component location.



**Figure 7-2.** 43iQ Component Layout Top View

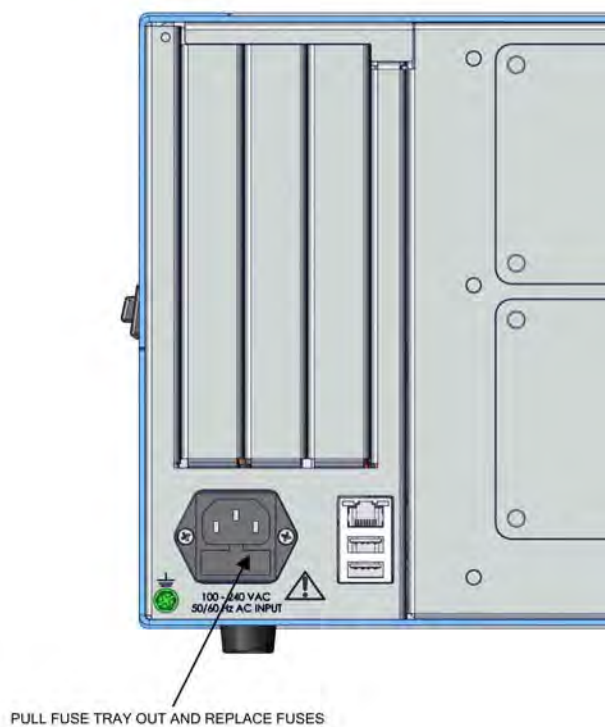


**Figure 7-3.** 43iQ Component Layout Side View

## Fuse Replacement

Use the following procedure to replace the fuses.

1. Turn instrument OFF and unplug the power cord.
2. Remove fuse drawer, located on the AC power connector.
3. If either fuse is blown, replace both fuses.
4. Insert fuse drawer and reconnect power cord.



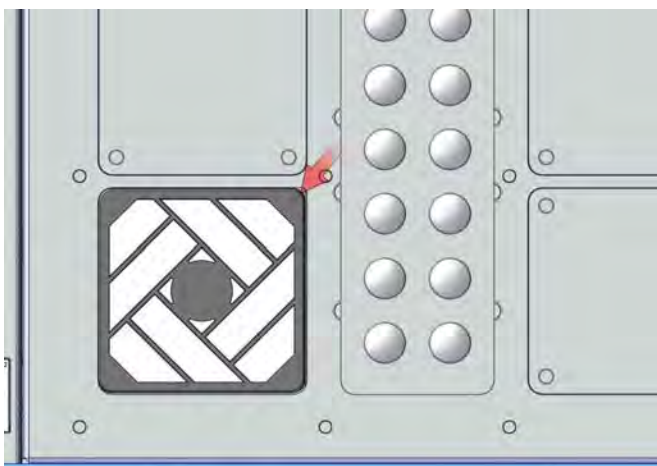
**Figure 7-4.** Replacing the Fuses



## Filter Replacement

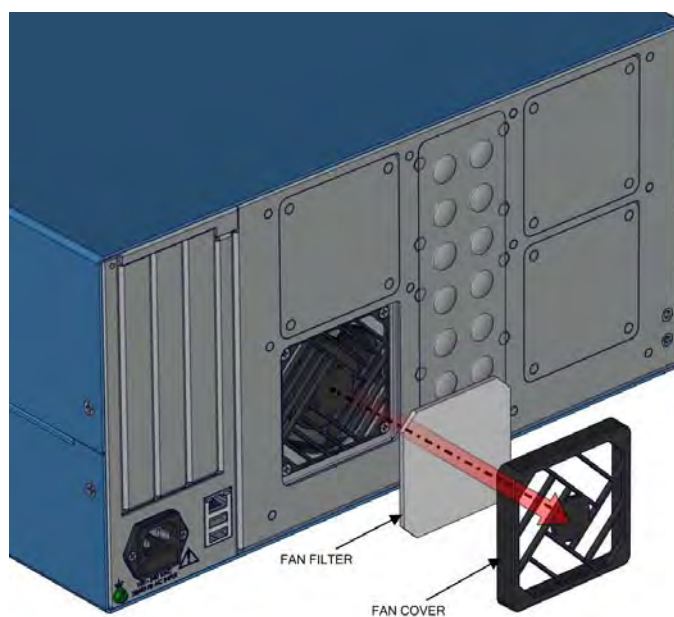
Use the following procedure to replace the filter.

1. Turn instrument OFF and unplug the power cord.
2. Starting with top right corner, pull out to remove fan cover.



**Figure 7-5.** Start with Top Right Corner of Fan Cover

3. Replace filter and snap fan cover back in place.



**Figure 7-6.** Removing the Fan Cover

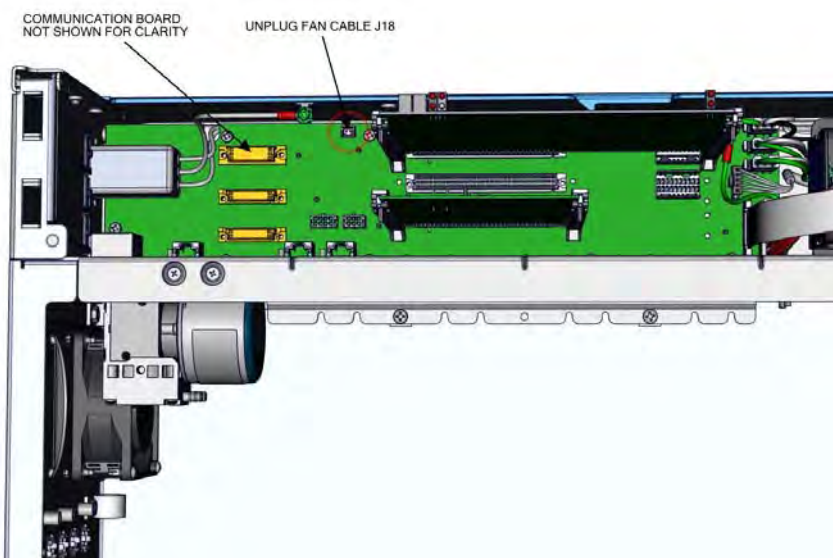
## Fan Replacement

Use the following procedure to replace the fan.

Equipment required:

Phillips drive, #2

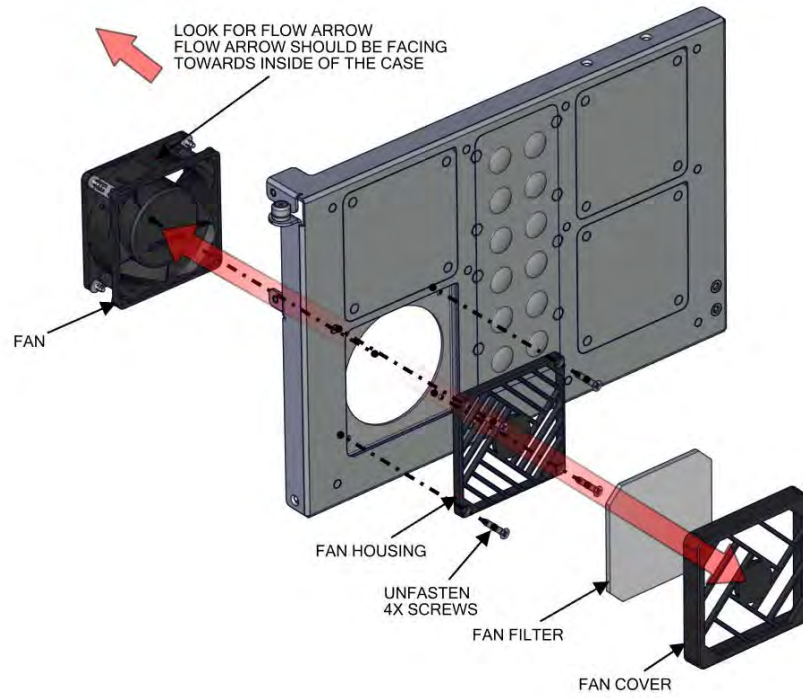
1. Turn instrument OFF, unplug power cord, and remove the cover (Figure 2-1).
2. Unplug the fan cable J18.



**Figure 7-7.** Unplugging the Fan Cable

3. Starting with top right corner, pull out to remove fan cover.
4. Unhook the four latches of the fan cover.
5. Unfasten the four 6-32 screws from the fan housing.
6. Replace fan and reassemble in reverse order.

**Servicing**  
Fan Replacement



**Figure 7–8.** Replacing the Fan

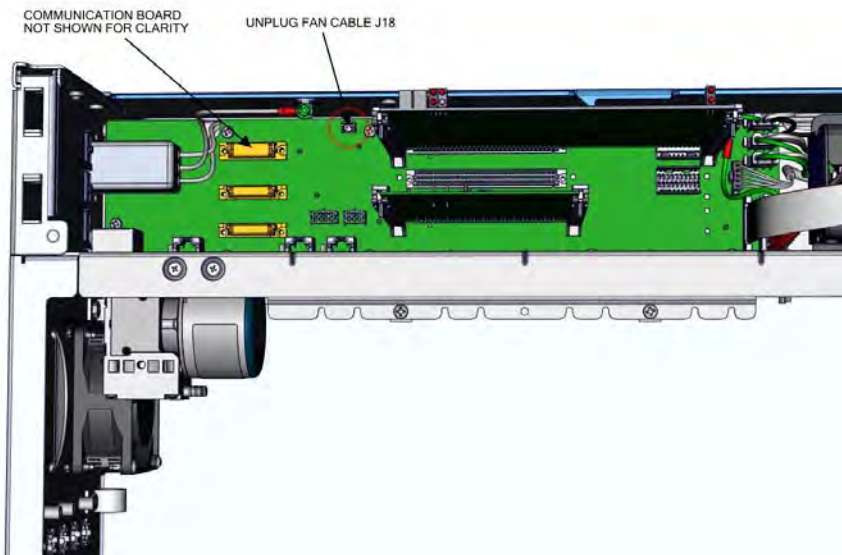
## Measurement Side Removal and Replacing

Use the following procedure to remove and replace the measurement side if necessary.

Equipment required:

Phillips drive, #2

1. Turn instrument OFF, unplug power cord, and remove the cover (Figure 2–1).
2. Unplug the fan cable J18 (Figure 7–9).

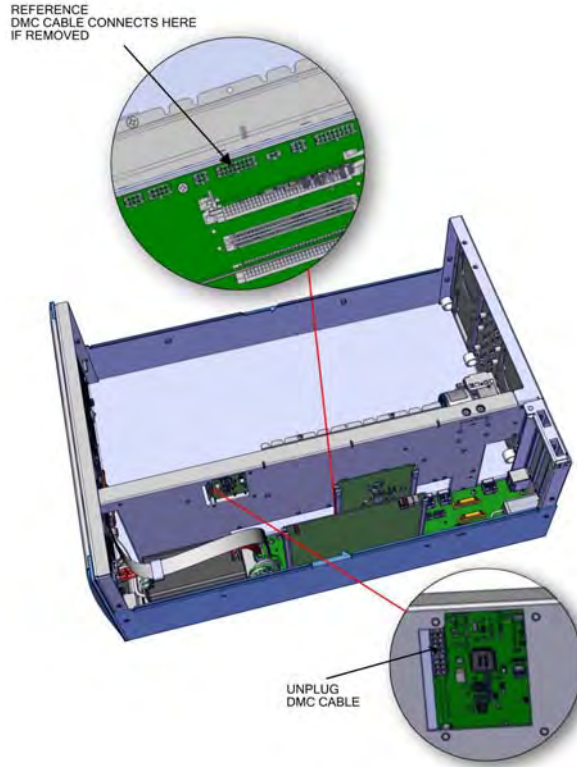


**Figure 7–9.** Unplugging the Fan Cable

3. Unplug DMC cable (Figure 7–10).

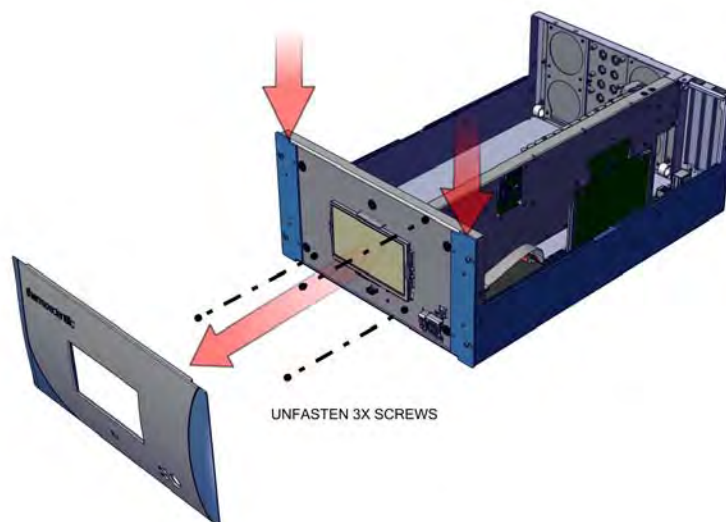
## Servicing

### Measurement Side Removal and Replacing



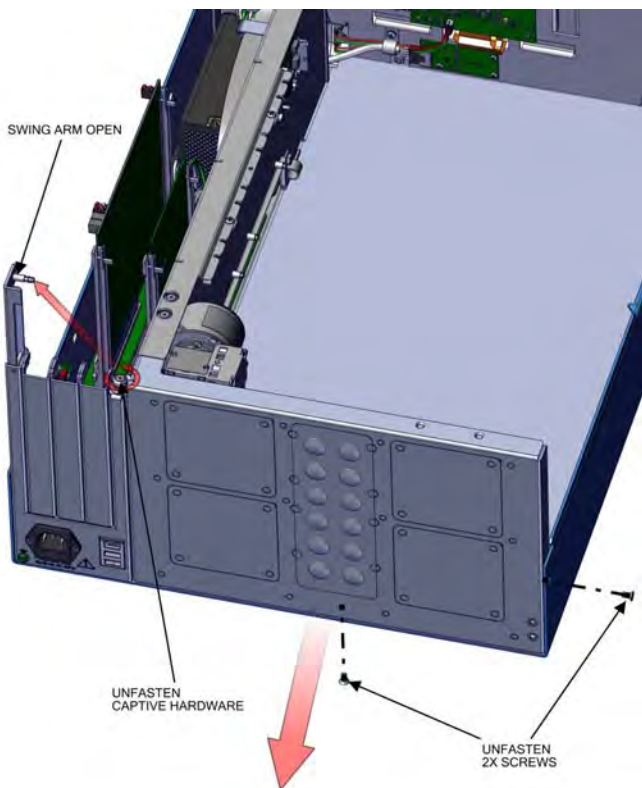
**Figure 7-10.** Unplugging the DMC Cable

4. Gripping from the top corners of the front panel and pull outwards.
5. Remove three 8-32 flat head screws (Figure 7-11).



**Figure 7-11.** Unfasten Hardware Front for Measurement Side Removal

6. Swing arm open.
7. Unfasten captive hardware.
8. Remove two 8-32 flat head screws.
9. Pull measurement side out.
10. Replace in reverse order.



**Figure 7–12.** Unfasten Hardware Rear for Measurement Side Removal

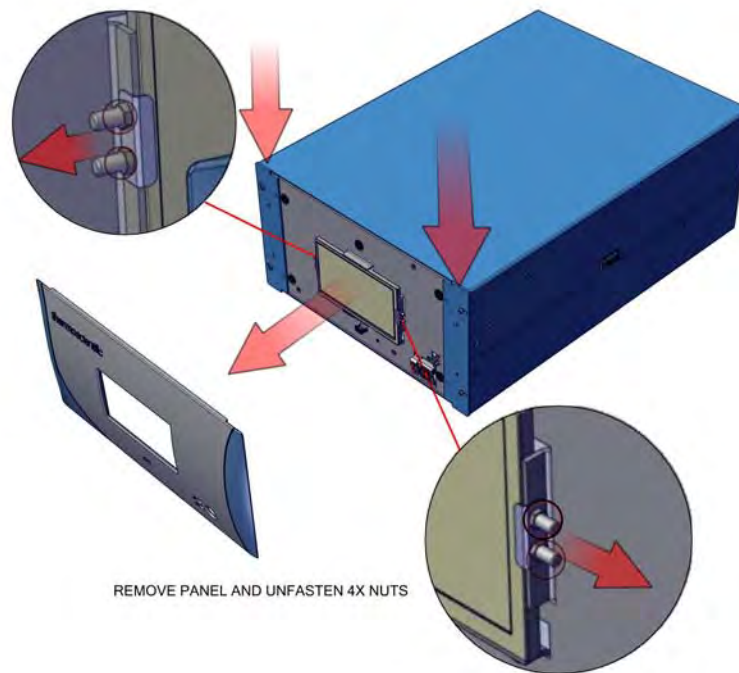
## LCD Module Replacement

Use the following procedure to replace the LCD module.

Equipment required:

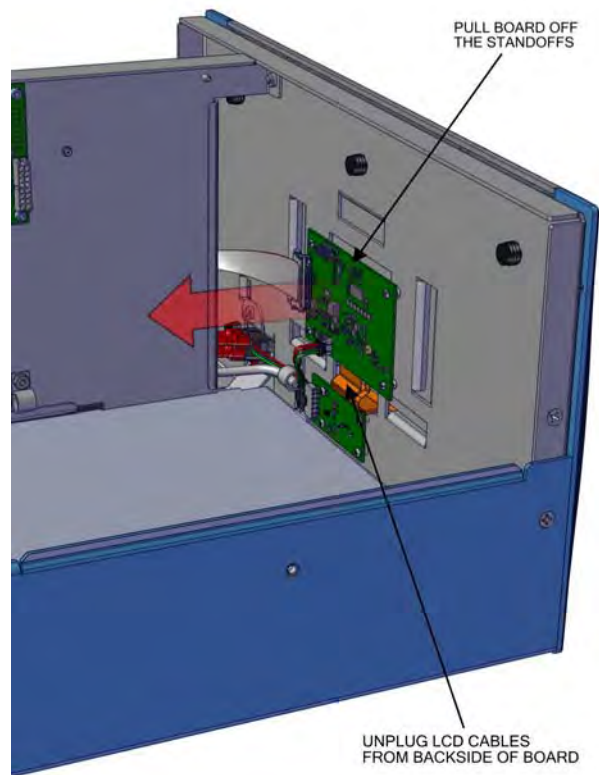
Wrench, 1/4

1. Turn instrument OFF and unplug the power cord.
2. Gripping from the top corners of the front panel and pull outwards.
3. Unfasten four nuts (Figure 7–13).



**Figure 7–13.** Replacing the LCD Module

4. Remove cover.
5. Unplug LCD cables from backside of board.
6. Pull board off the standoffs.



**Figure 7-14.** Remove Electrical Cables from LCD

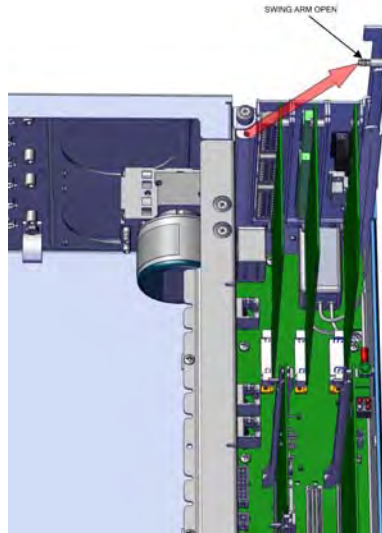
7. Replace LCD module and reassemble in reverse order.



## I/O Replacement

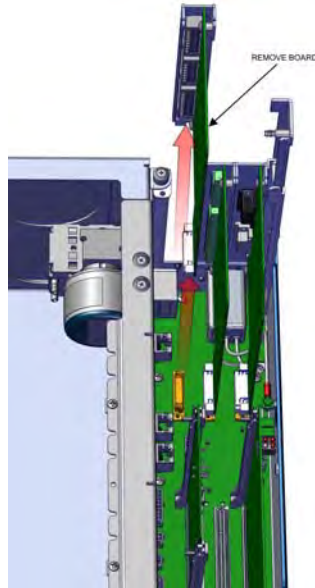
Use the following procedure to replace the I/O boards.

1. Turn instrument OFF, unplug power cord, and remove the cover (Figure 2-1).
2. Swing arm open.



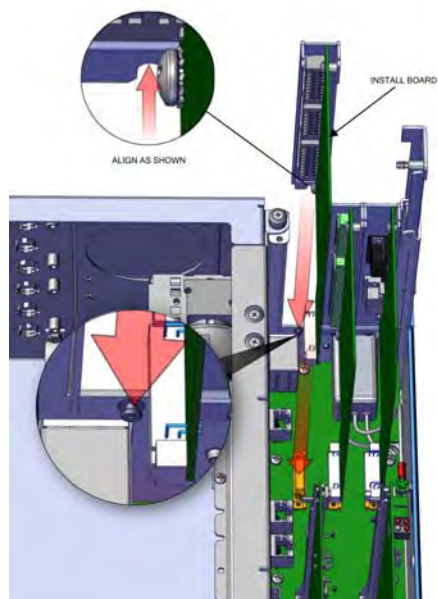
**Figure 7-15.** I/O Replacement, Arm

3. Pull board upwards.



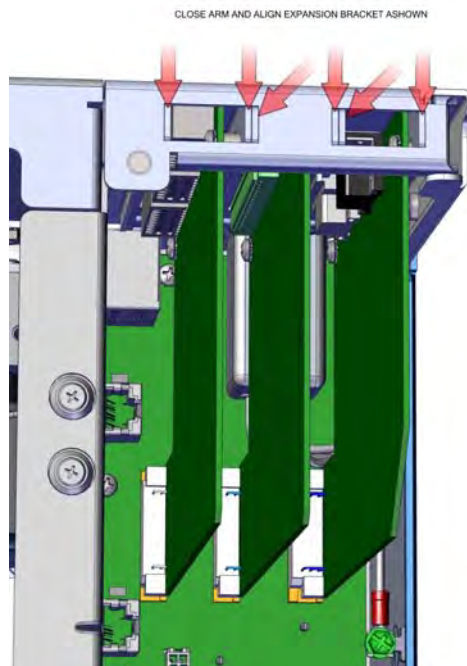
**Figure 7-16.** I/O Replacement, Remove Board

4. During install, make sure to align cutout circular to keyway.
5. Insert board downwards.



**Figure 7-17.** I/O Replacement, Install

6. Close arm. Make sure expansion bracket aligns to the inside of the rectangular cutouts.

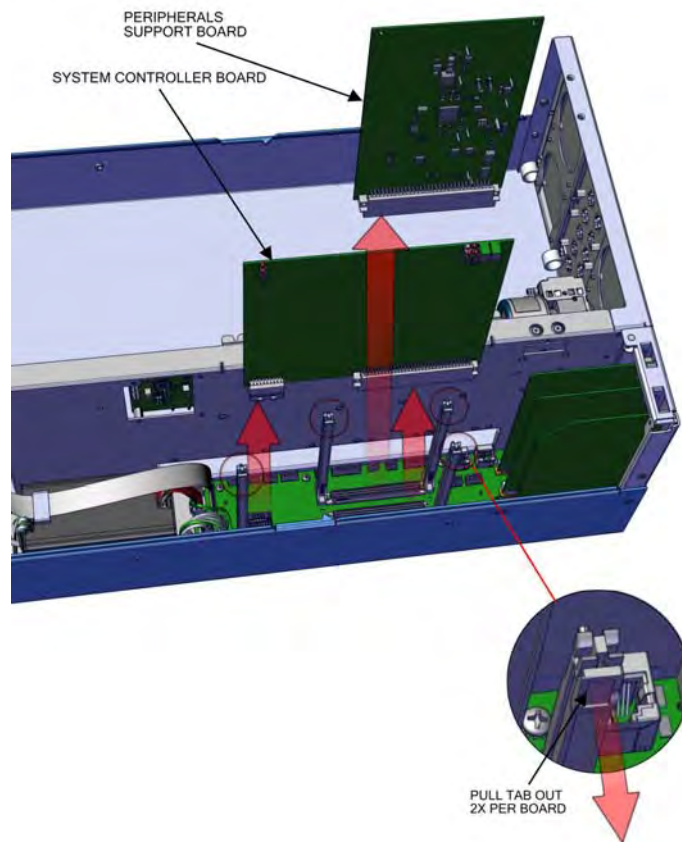


**Figure 7-18.** I/O Replacement, Close Arm Alignment

# Peripherals Support Board and System Controller Board Replacement

Use the following procedure to replace the peripherals support board or system controller board.

1. Turn instrument OFF, unplug power cord, and remove the cover (Figure 2–1).
2. Pull tab out (two per board).
3. Pull board out.



**Figure 7–19.** Replacing the Peripherals Support Board

4. Replace board and reassemble in reverse order.

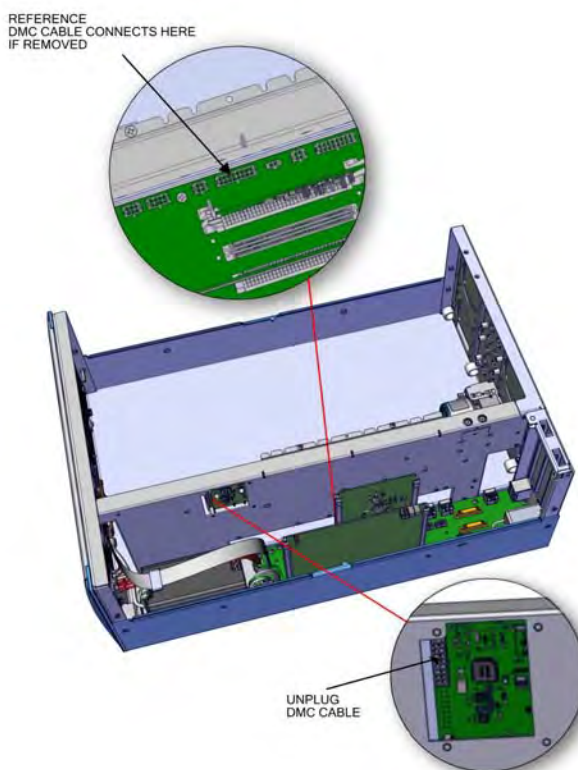
## DMC Pressure and Flow Board

Use the following to replace the DMC pressure and flow board.

Equipment required:

Hex drive, 7/16

1. Turn instrument OFF, unplug power cord, and remove the cover (Figure 2–1).
2. Unplug cables from the pressure and flow board.

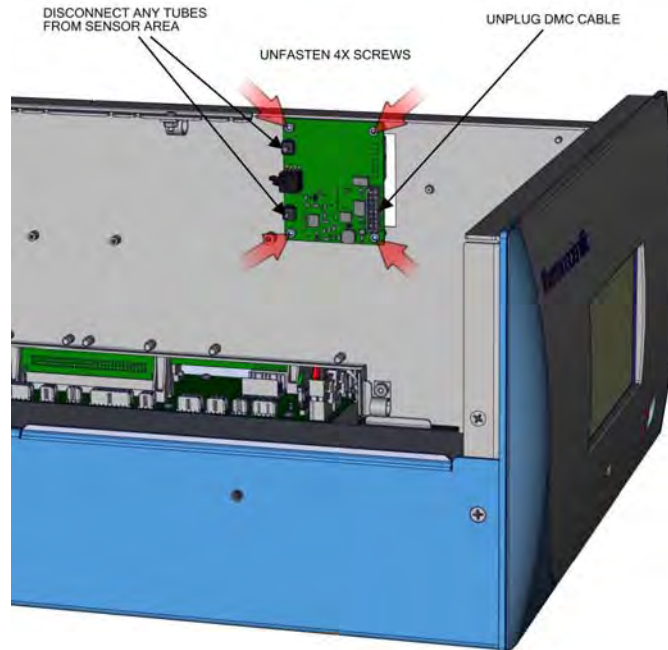


**Figure 7–20.** Flow Pressure Board, Disconnect DMC Cable

3. Disconnect plumbing.
4. Using 7/16 hex drive, unfasten four #6-32 socket cap head screws.

## Servicing

### DMC Pressure and Flow Board



**Figure 7–21.** Flow Pressure Board, Screws

5. Replace board and reassemble in reverse order.

## **Pump Replacement**

Use the following procedure to replace the pump.

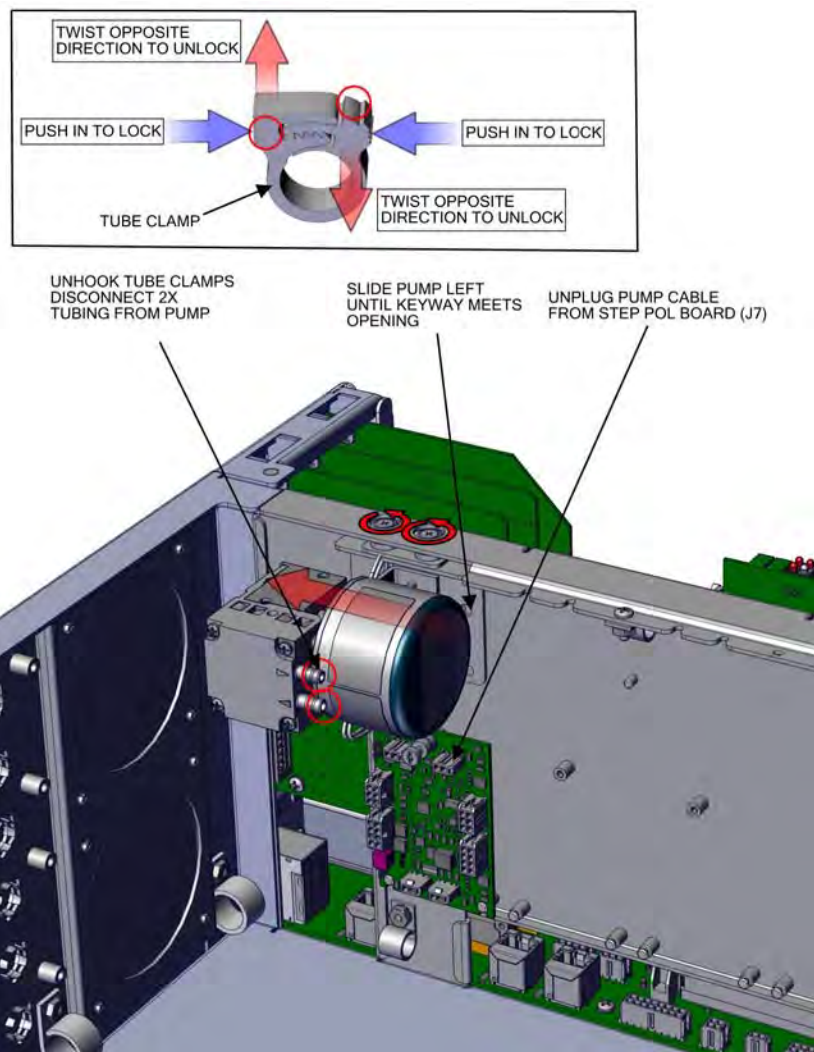
Equipment required:

Phillips drive, #1 and #2

1. Turn instrument OFF, unplug power cord, and remove the cover (Figure 2-1).
2. Unplug pump cable from step POL board J7.
3. Twist opposite direction to unlock tube clamps.

**Note** Push in tube clamp to lock. ▲

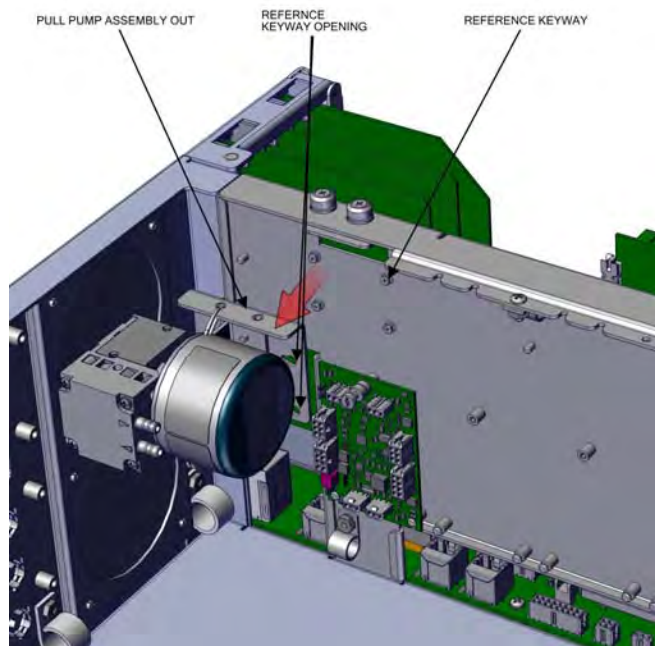
4. Disconnect tubing from pump.
5. Unfasten two captive hardware.
6. Slide pump left until keyway meets opening.



**Figure 7–22.** Remove Pump, Disconnect and Unfasten

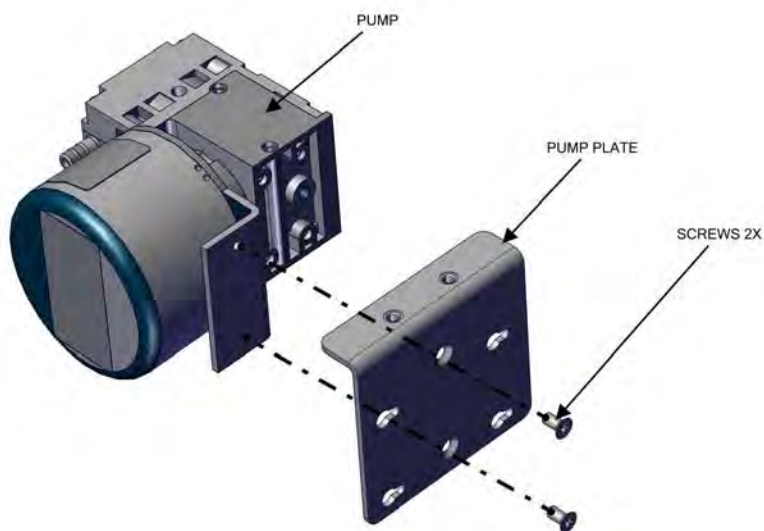
7. Pull pump outwards.

**Note** When installing pump, make sure the pump keyway opening goes over the keyway. ▲



**Figure 7–23.** Pump Removal, Keyway

8. Remove two screws.



**Figure 7–24.** Pump replacing, Unfasten Screws

9. Replace pump and reassemble in reverse order.



## Capillary Cleaning and/or Replacement

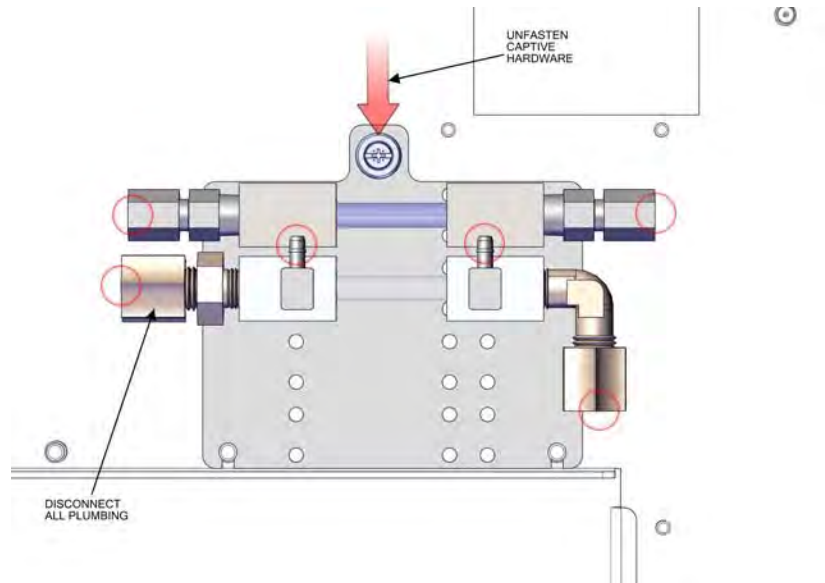
Use the following procedure to clean or replace the capillary.

Equipment required:

Phillips drive, #2

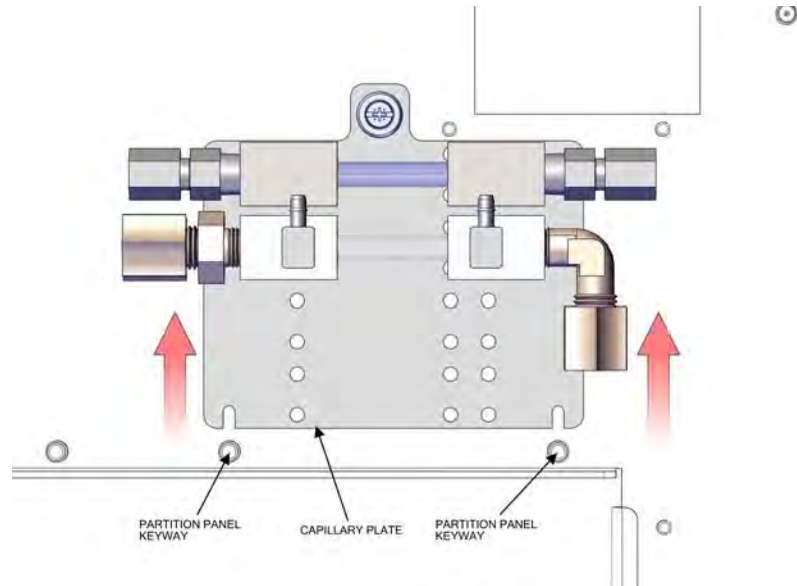
Hex drive, 7/64

1. Turn instrument OFF, unplug power cord, and remove the cover (Figure 2–1).
2. Disconnect the plumbing.
3. Unfasten captive hardware.



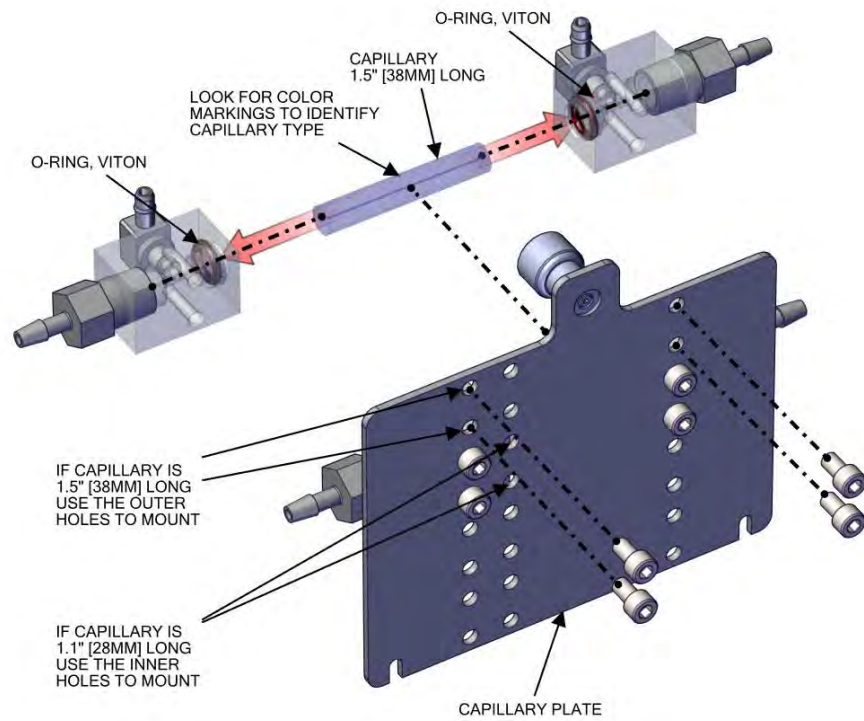
**Figure 7–25.** Remove Capillary, Disconnect and Unfasten

4. Slide capillary plate upwards clearing the partition panel keyway.



**Figure 7-26.** Capillary Plate, Keyway

5. Using 7/64 hex drive, remove four #6-32 socket cap head screws.
6. Pull apart the capillary blocks.



**Figure 7-27.** Capillary and O-Ring Replace

7. Replace capillary and reassemble in reverse order.

**Note** Fitting arrangements, number of capillaries and capillary sizes will vary per instrument configuration. ▲

## Capillary O-Ring Replacement

Use the following procedure to replace the capillary o-rings.

Equipment required:

O-ring pick tool

1. Using a plastic o-ring pick tool, remove the o-ring.

**Note** Be careful in not damaging the o-ring walls during this process. Refer to [Figure 7–27](#). ▲

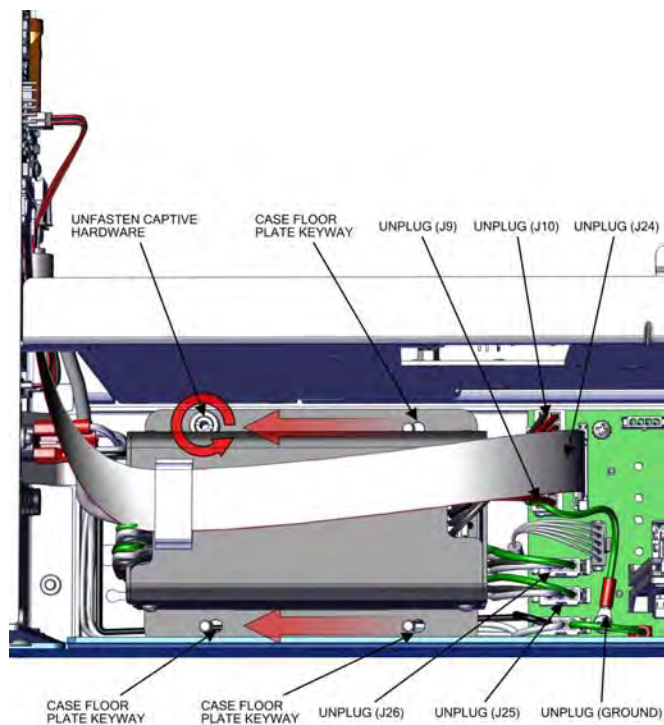
## Power Supply Replacement

Use the following procedure to replace the power supply.

Equipment required:

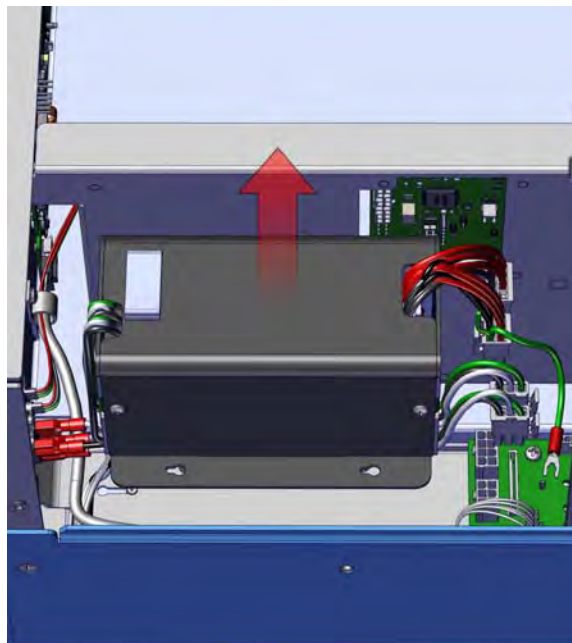
Phillips drive, #2

1. Turn instrument OFF, unplug power cord, and remove the cover ([Figure 2–1](#)).
2. Unplug all electrical shown J9, J10, J24, J25, J26, and ground.
3. Unfasten captive hardware.
4. Slide power supply left, clearing three case floor plate keyways.



**Figure 7–28.** Removing Power Supply

5. Pull power supply up.
6. Replace power supply and reassemble in reverse order.



**Figure 7–29.** Replacing Power Supply

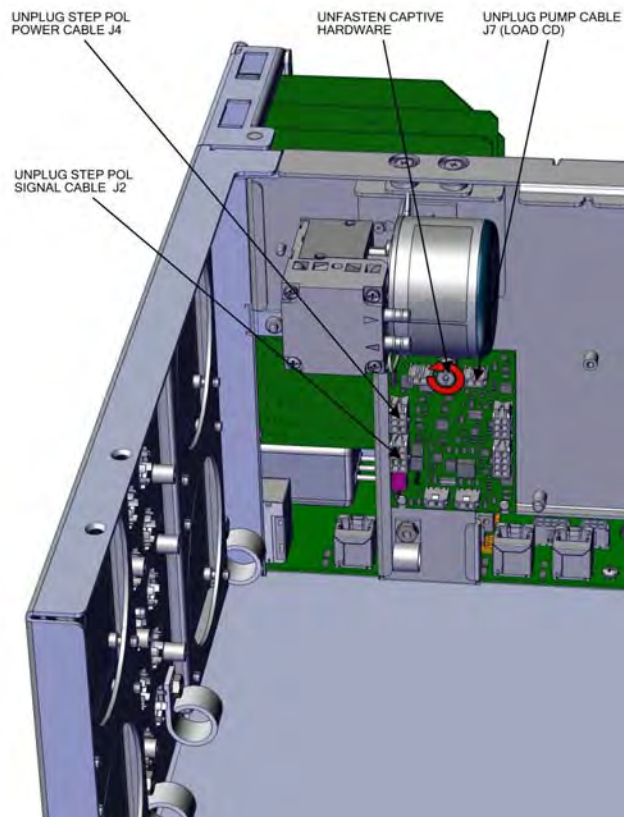
## Step POL Board Replacement

Use the following procedure to replace the Step POL Board.

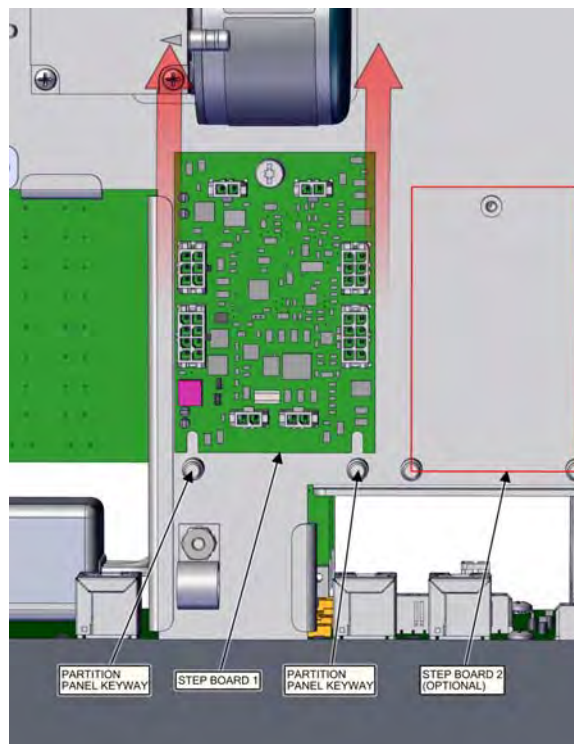
Equipment required:

Torque screwdriver, T15 or Slot screwdriver, 3/16

1. Turn instrument OFF, unplug power cord, and remove the cover (Figure 2–1).
2. Unplug step POL power cable J4.
3. Unplug step POL signal cable J2.
4. Unplug pump cable J7.
5. Unfasten captive hardware.

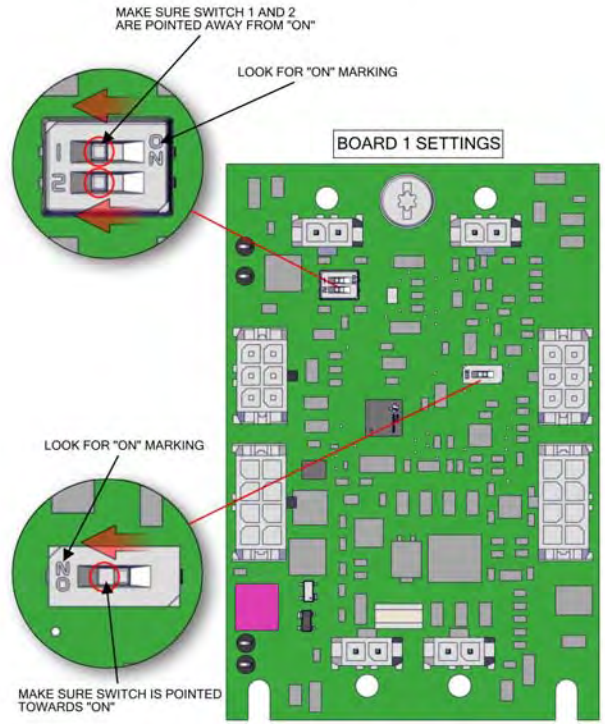


**Figure 7–30.** Unplug and Unfasten Step POL Board

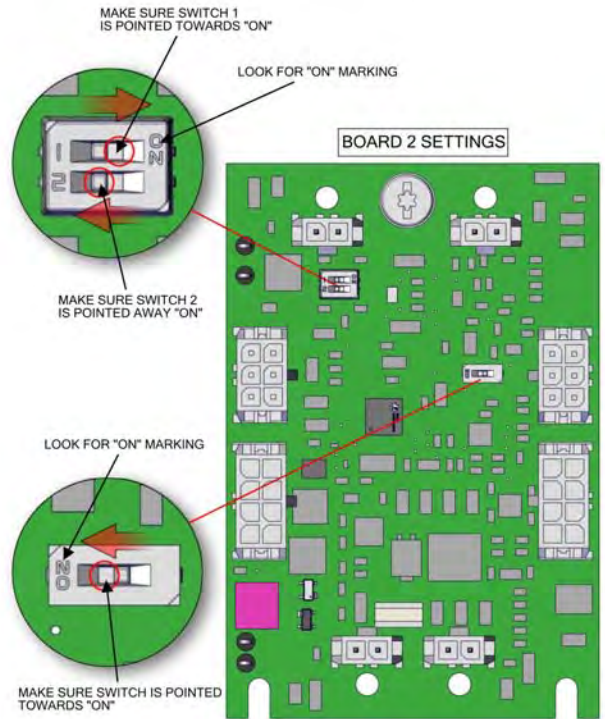


**Figure 7–31.** Clear Partition Keyway Step POL Board

6. Slide step board 1 upwards clearing the partition panel keyway.
7. If replacing step board 1, make sure switch 1 and 2 are pointed away from ON (Figure 7–32). If replacing optional step board 2, make sure switch 1 is pointed towards ON and switch 2 is pointed away from ON (Figure 7–33).
8. Replace step POL board and reassemble in reverse order.



**Figure 7-32.** Step POL Board 1 Switch Settings



**Figure 7-33.** Optional Step POL Board 2 Switch Settings

## DMC Optical Bench Removal

Use the following to remove the DMC optical bench from the instrument.

- Optical Bench Assembly Removal
- PMT Replacement
- Flasher Pack Replacement
- Flasher Pack Lamp Replacement
- Photo Lamp Detector Board Replacement
- Kicker Assembly Replacement

## Optical Bench Assembly Removal

Use the following procedure to remove the optical bench assembly.

Equipment required:

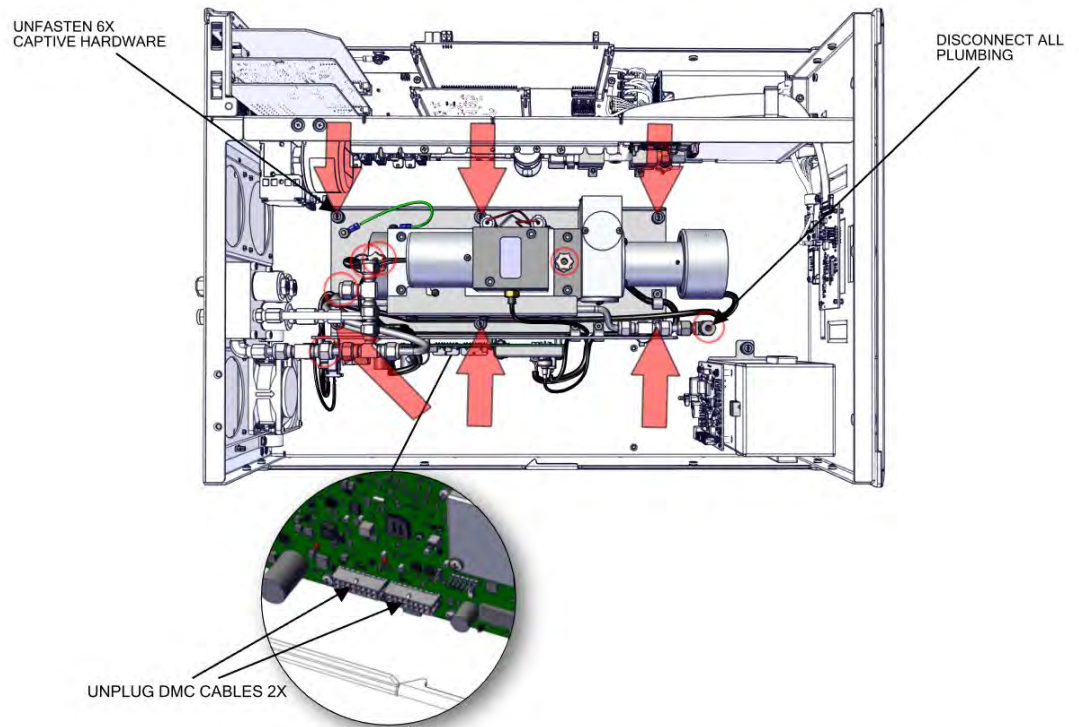
Phillips drive, #2

1. Turn instrument OFF, unplug power cord, and remove the cover (Figure 2-1).
2. Unplug two DMC cables.
3. Disconnect all plumbing.
4. Unfasten six captive hardware.



## Servicing

### DMC Optical Bench Removal



**Figure 7–34.** Removing the DMC Optical Bench Removal from Instrument

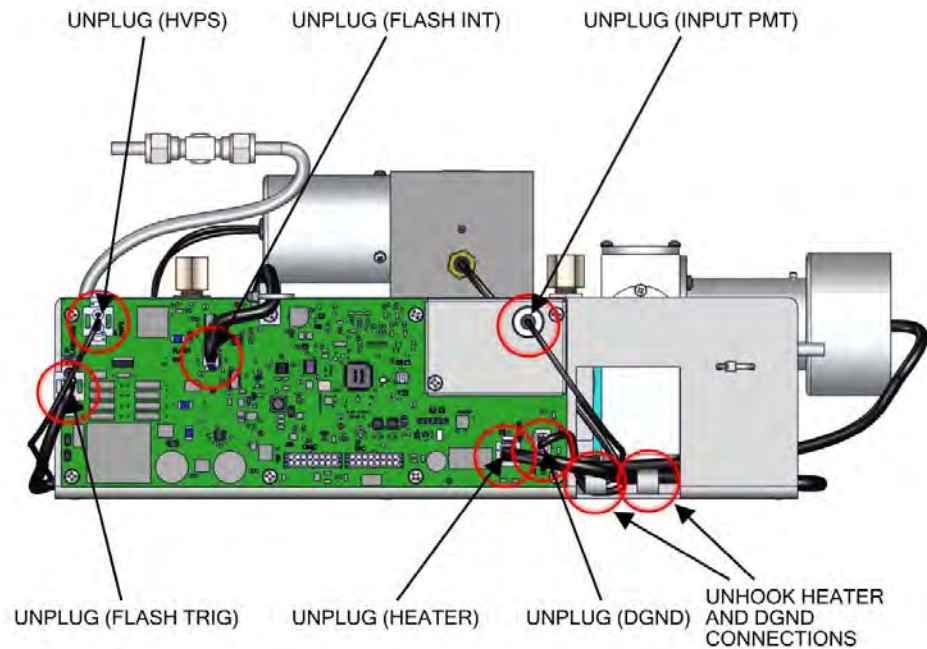
## Optical Bench Assembly Removal

Use the following to remove the optical bench assembly.

Equipment required:

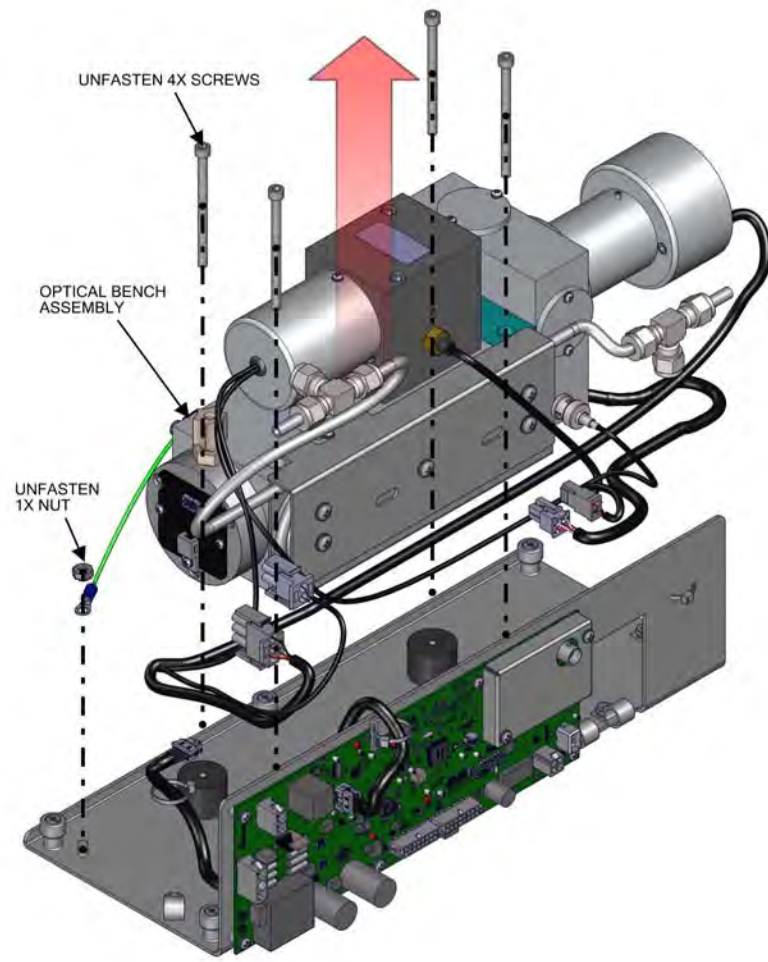
Hex nut drive, 3/8 and 5/32

1. Unplug all electrical as shown (Figure 7–35).



**Figure 7–35.** Removing the Optical Bench Assembly

2. Unfasten 10-32 nut.
3. Unfasten four 10-32 screws.
4. Pull optical bench assembly upwards (Figure 7–36).



**Figure 7-36.** Removing the Optical Bench Assembly pt 2

## Photomultiplier Tube (PMT) Replacement

Use the following to replace the photomultiplier tube (PMT).

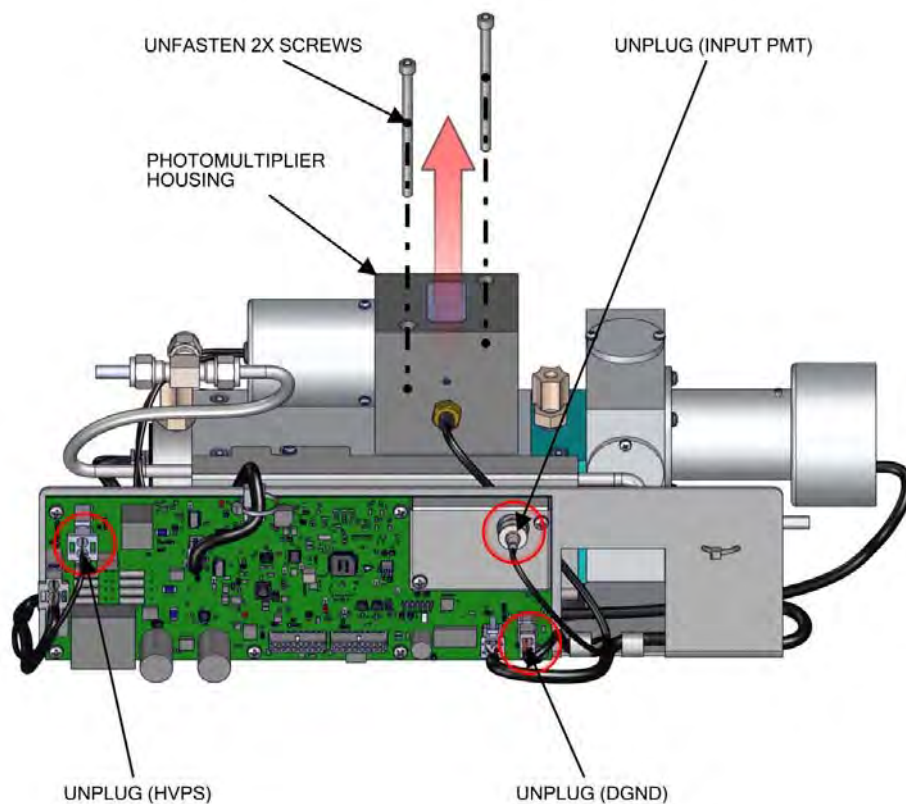
Equipment required:

Hex drive, 5/32

Phillips drive, #1 and #2

Lint-free gloves

1. Turn the instrument OFF, unplug the power cord, and remove the cover.
2. Unplug all electrical as shown (Figure 7-37).
3. Unfasten two 10-32 screws.
4. Pull photomultiplier housing upwards.



**Figure 7-37.** Removing the PMT Assembly

5. Unfasten three 4-40 screws.



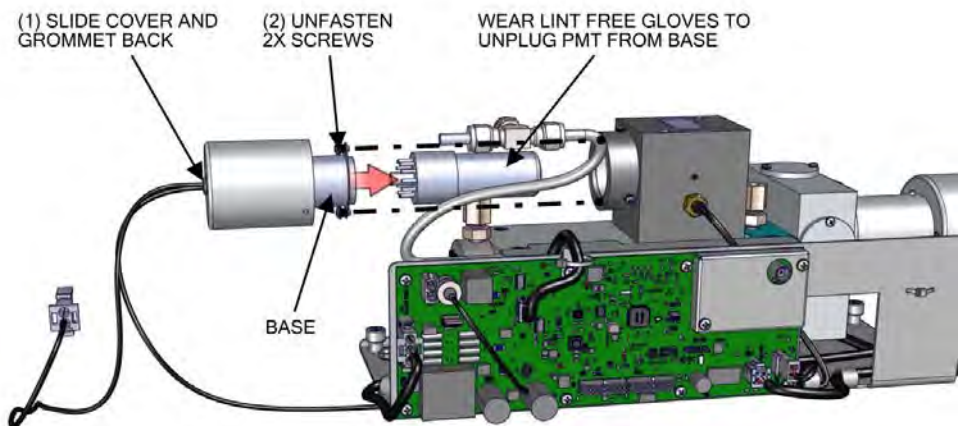
**Figure 7-38.** Removing the PMT Cover

6. Slide cover and grommet back.

**Note** Wear lint-free gloves to unplug PMT from base. ▲

7. Unfasten two 6-32 screws.

8. Replace PMT as needed and assemble in reverse order.



**Figure 7-39.** Replacing the PMT

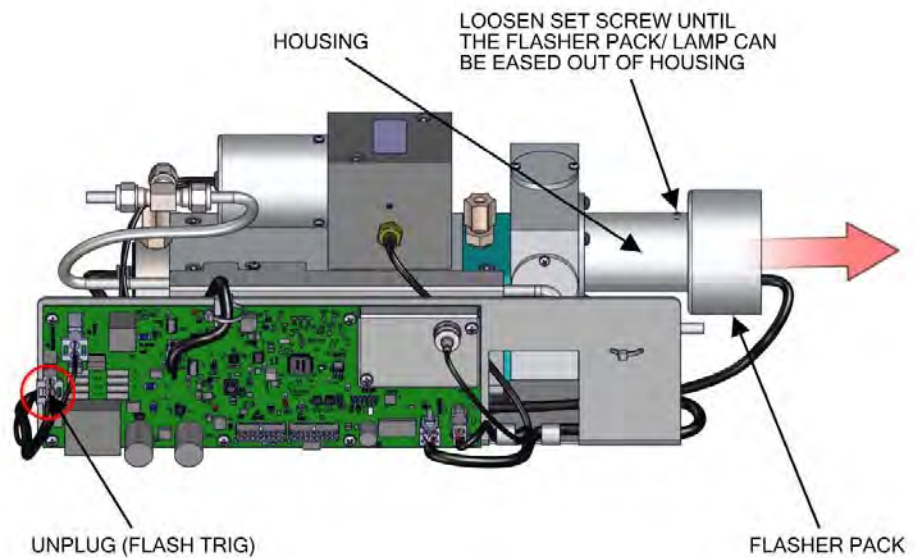
## Flasher Pack Replacement

Use the following procedure to replace the flasher pack.

Equipment required:

Hex drive, 1/16

1. Unplug flash trig from board.
2. Loosen 6-32 set screw until the flasher pack/lamp can be eased out of housing.



**Figure 7–40.** Removing and Replacing the Flasher Pack

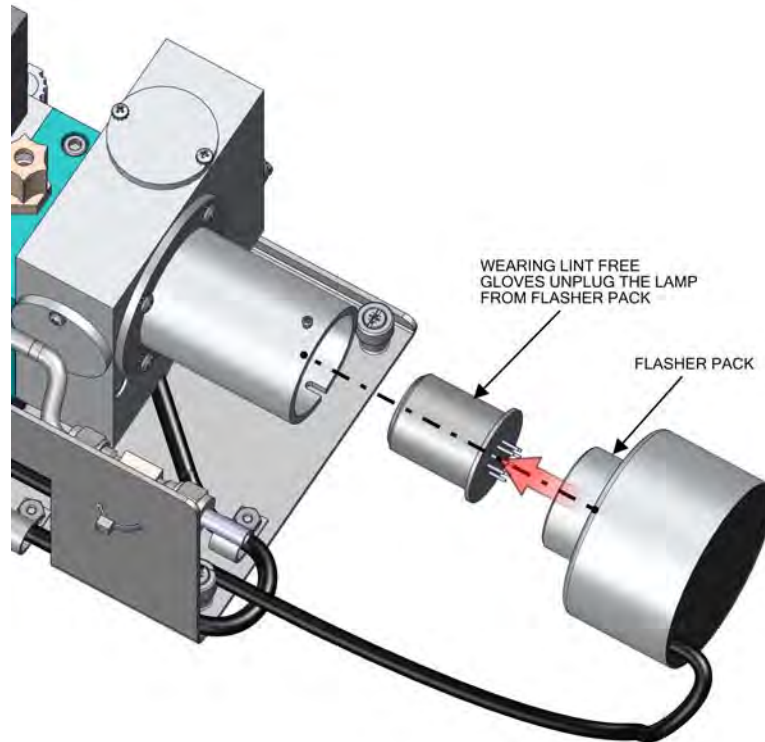
## Flasher Pack Lamp Replacement

Use the following procedure to replace and flasher pack lamp.

Equipment required:

Lint-free gloves

1. Wearing lint-free gloves unplug the lamp from the flasher pack.



**Figure 7-41.** Replacing the Flasher Pack Lamp

2. Replace flasher pack lamp and assemble in reverse order.

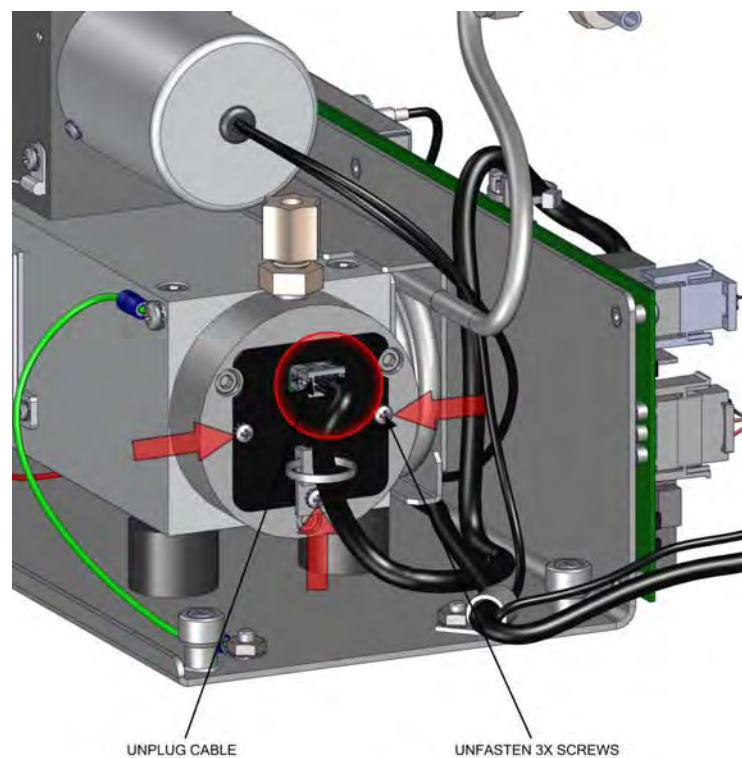
## Photo Lamp Detector Board Replacement

Use the following procedure to remove and replace the photo lamp detector board.

Equipment required:

Phillips drive, #1 and #2

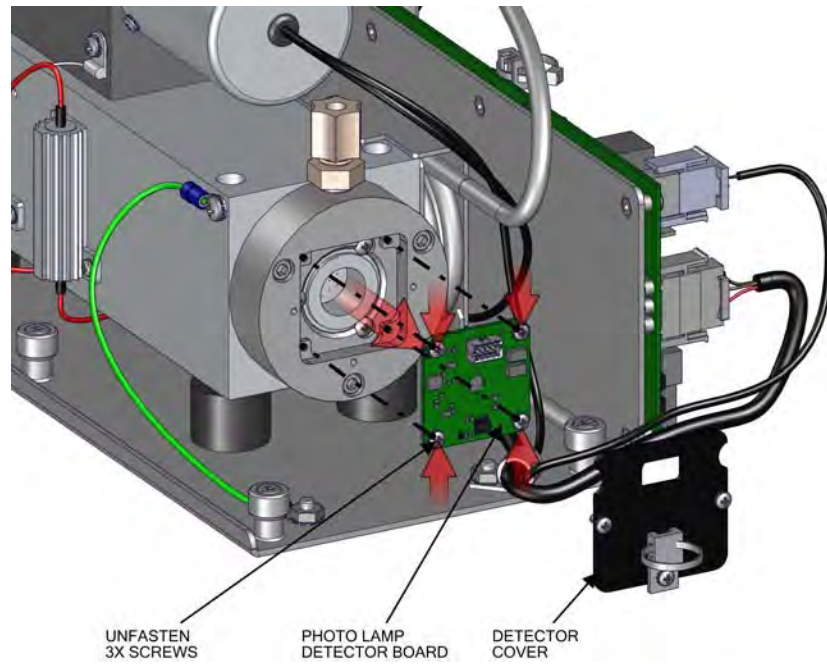
1. Unplug cable.
2. Unfasten three 6-32 screws.



**Figure 7-42.** Replacing the Photo Lamp Detector Board pt 1

3. Pull detector cover outwards.
4. Unfasten four 4-40 screws.
5. Pull photo lamp detector board outwards.
6. Replace lamp detector board and assemble in reverse order.





**Figure 7-43.** Replacing the Photo Lamp Detector board pt 2

## Kicker Assembly Replacement

Use the following procedure to replace the kicker assembly (Figure 7-44).

Equipment required:

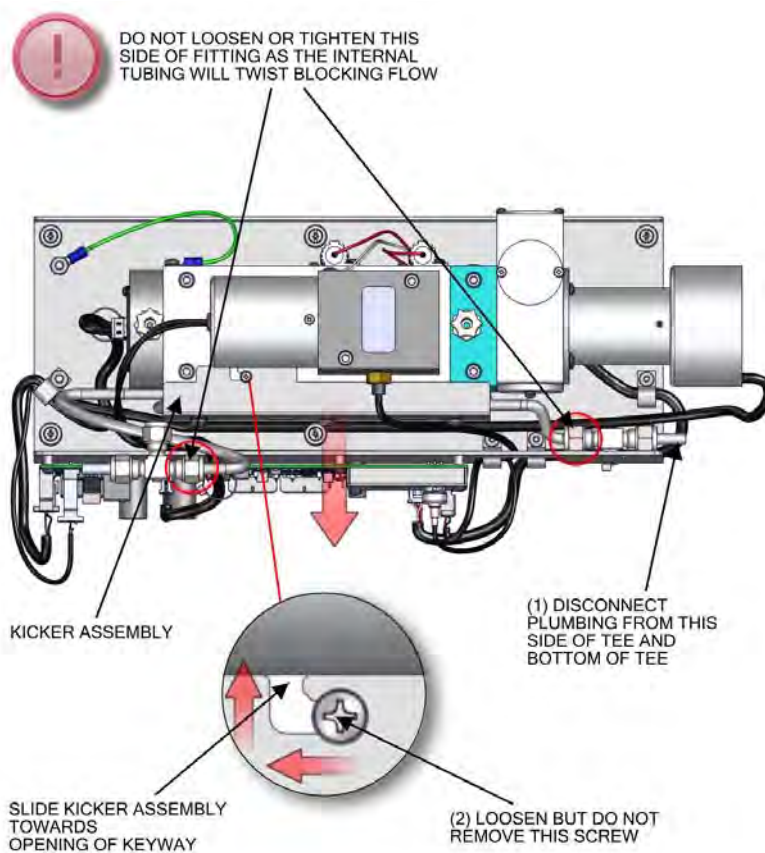
Phillips drive, #1

1. Disconnect plumbing as shown.
2. Loosen 4-40 screw. Slide kicker assembly towards opening of keyway.



**Equipment Damage** Do not loosen or tighten this side of fitting as the internal tubing will twist blocking flow. These fittings are covered by silicone tape as a reminder. ▲

3. Once kicker assembly clears the keyway, pull outwards towards the board and up.



**Figure 7-44.** Removing and Replacing the Kicker Assembly

## Optional Manifold Replacement

4. Replace the kicker assembly and assemble in reverse order.

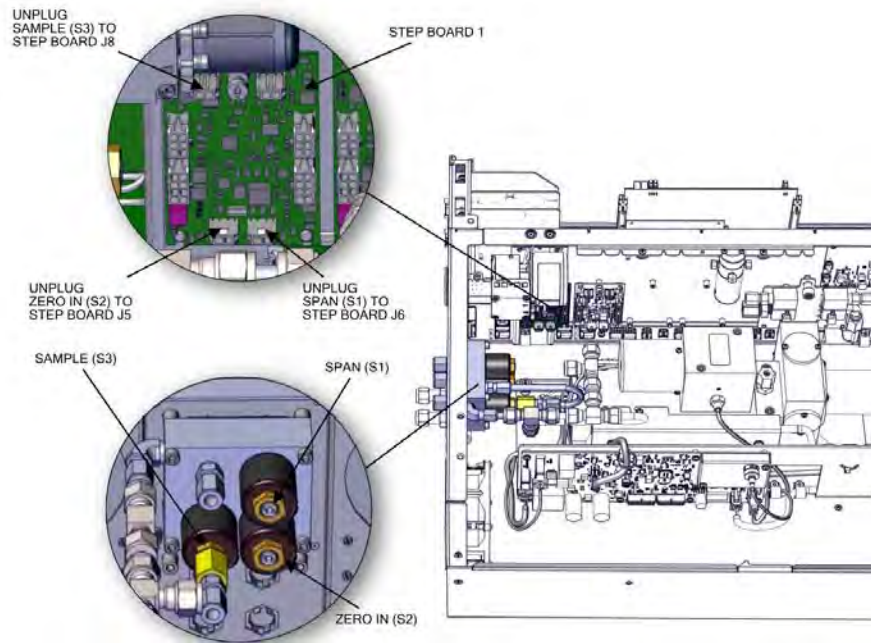
Use the following procedure to replace the manifold.

Equipment required:

Hex wrench, 9/16

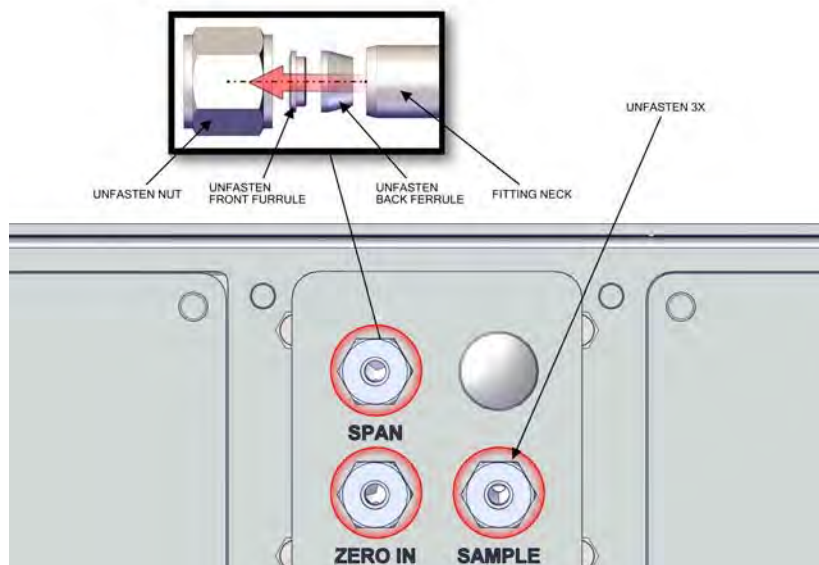
Hex drive, 9/64

1. Turn the instrument OFF, unplug the power cord, and remove the cover (Figure 2-1).
2. Unplug three electrical connections (J5, J6, and J8) from the step POL board 1.



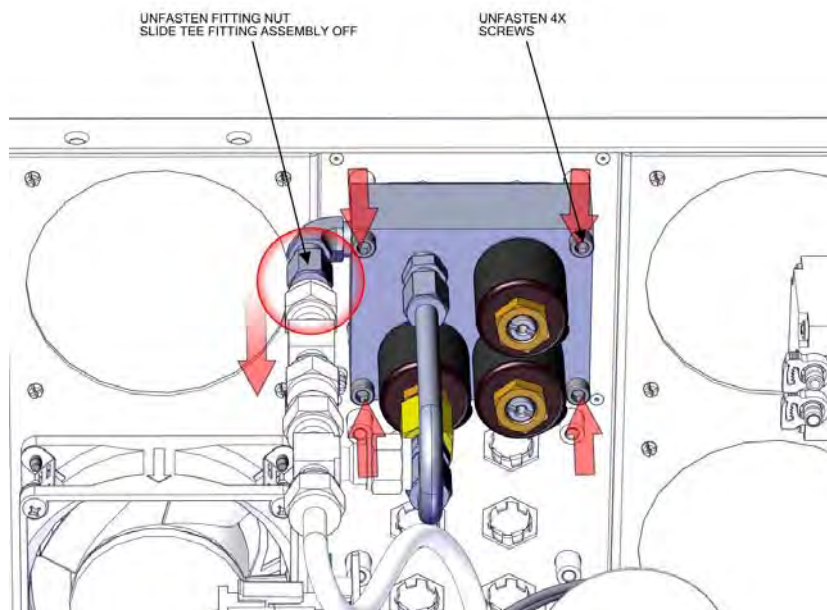
**Figure 7-45.** Replacing the Manifold pt 1

3. Unfasten three nuts. Remove the nuts, front and back ferrules as shown from span, zero in, sample back panel (Figure 7-46).



**Figure 7–46.** Replacing the Manifold pt 2

4. Unfasten fitting nut and slide tee fitting assembly off.
5. Unfasten four #8-32 screws.



**Figure 7–47.** Replacing the Manifold pt 3

6. Replace the manifold and assemble in reverse order.

# Optional DMC Permeation Oven Solenoid Valve Replacement

Use the following procedure to replace the DMC permeation oven solenoid valve option.

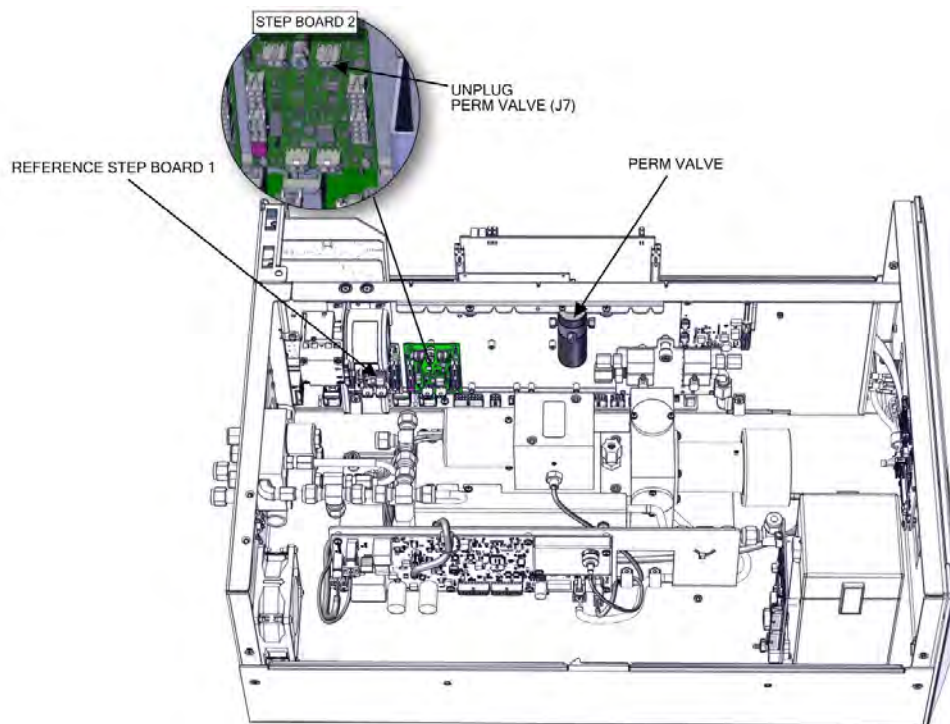
Equipment required:

Phillips drive, #1



**CAUTION** Allow the oven to cool down prior to servicing. ▲

1. Turn the instrument OFF, unplug the power cord, and remove the cover (Figure 2-1).
2. Unplug perm valve J7 from step pol board 2.

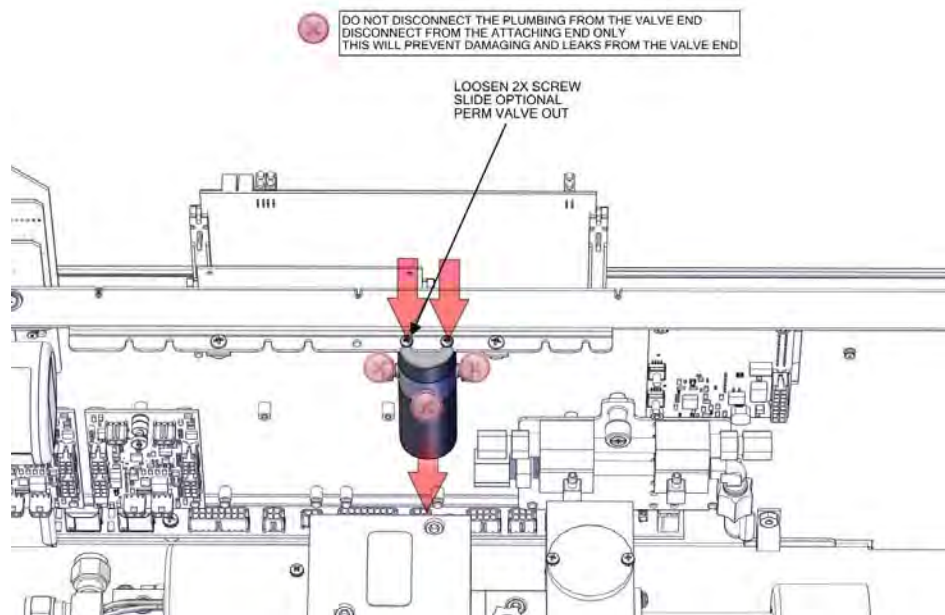


**Figure 7-48.** Removing and Replacing the Solenoid Valve pt 1

3. Loosen two 4-40 screws and slide optional perm valve out.



**Equipment Damage** Do not disconnect the plumbing from the valve end. Disconnect from the attaching end only. This will prevent damaging and leaks from the valve end. ▲



**Figure 7–49.** Removing and Replacing the Solenoid Valve pt 2

4. Replace the permeation oven solenoid valve and assemble in reverse order.

## Permeation Oven Replacement

Use the following procedure to replace the permeation oven.

Equipment required:

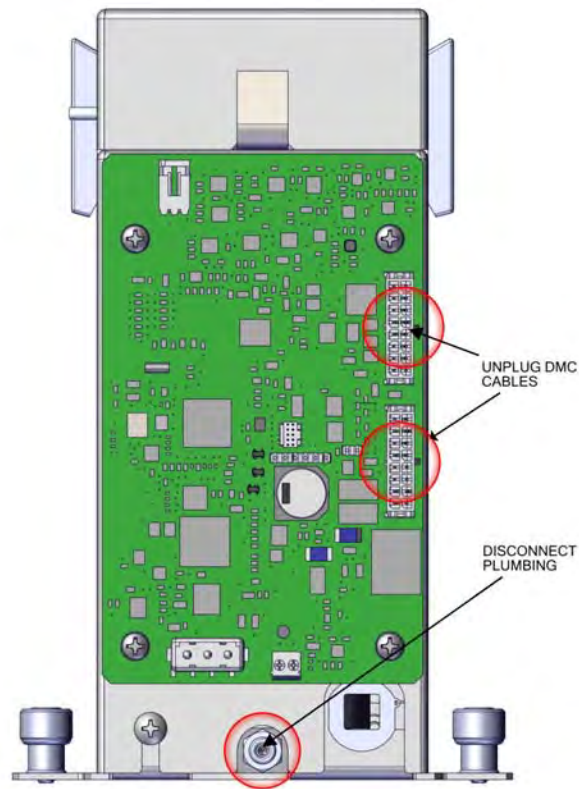
Phillips drive, #2

Tube release tool (optional)



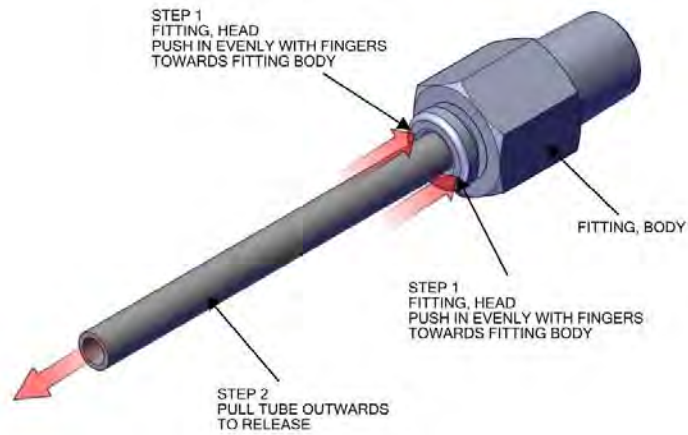
**CAUTION** Allow oven to cool down prior to servicing. ▲

1. Turn the instrument OFF, unplug the power cord, and remove the cover (Figure 2-1).
2. Unplug DMC cables as shown.
3. Disconnect plumbing.



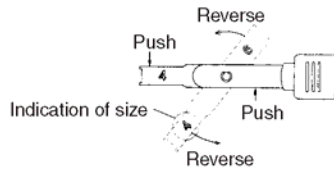
**Figure 7-50.** Perm Oven pt 1

4. Push in fitting head evenly with fingers towards fitting body.

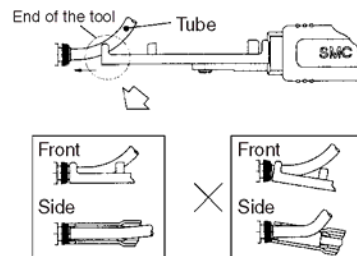


**Figure 7–51.** Finger Push and Release Tubing

5. Pull tube outwards to release. If using the tool provided:
  - a. Adjust tool size to 1/4 tube as indicated on the back side.



- b. Tool edge should be pushed straightforward into the edge of the release button along with the tube in the axial fitting direction.



- c. After inserting, grasp handle tightly and insert the end of the tubing to the stroke end.

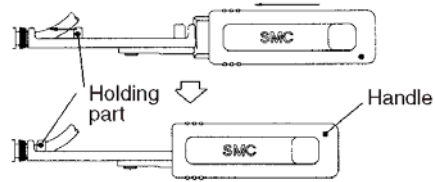
**Note** Insert firmly to the guard against an accidental tube release. ▲

- d. After inserting end of tube, relax your grip on the tool. Returning force of spring releases the tube.



## Servicing

### Permeation Oven Replacement

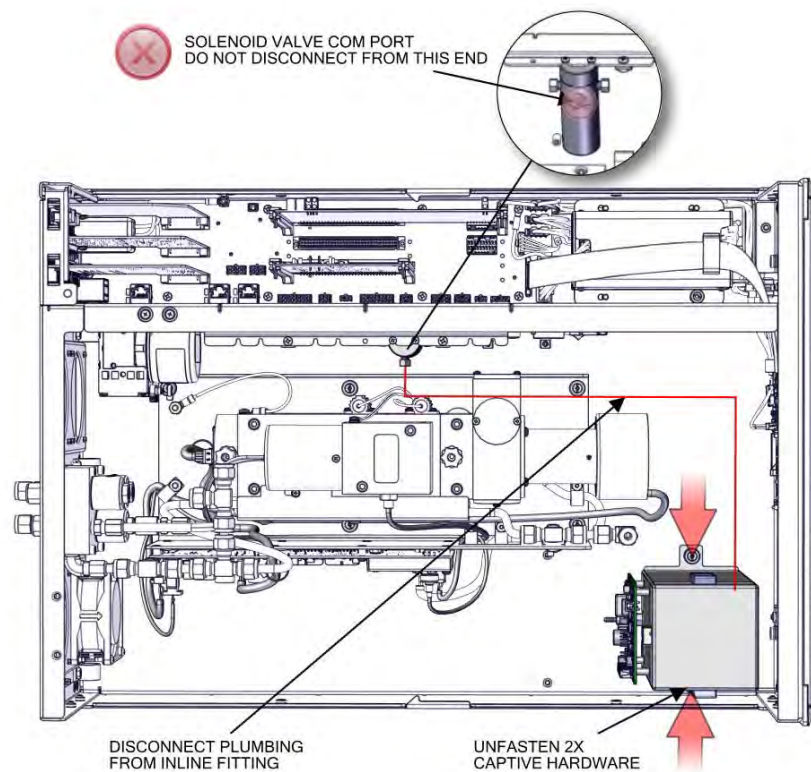


Push both sides at once to release. Reverse and fix at the same position as before. Applicable tube size is indicated on the back side.

6. Disconnect plumbing from inline fitting.

**Note** Do not disconnect from valve end. ▲

7. Unfasten two captive hardware.



**Figure 7-52.** Perm Oven Replacement pt 2

8. Replace DMC permeation oven and assembly in reverse order.

## Permeation Oven Board Replacement

Use the following procedure to replace the permeation oven board.

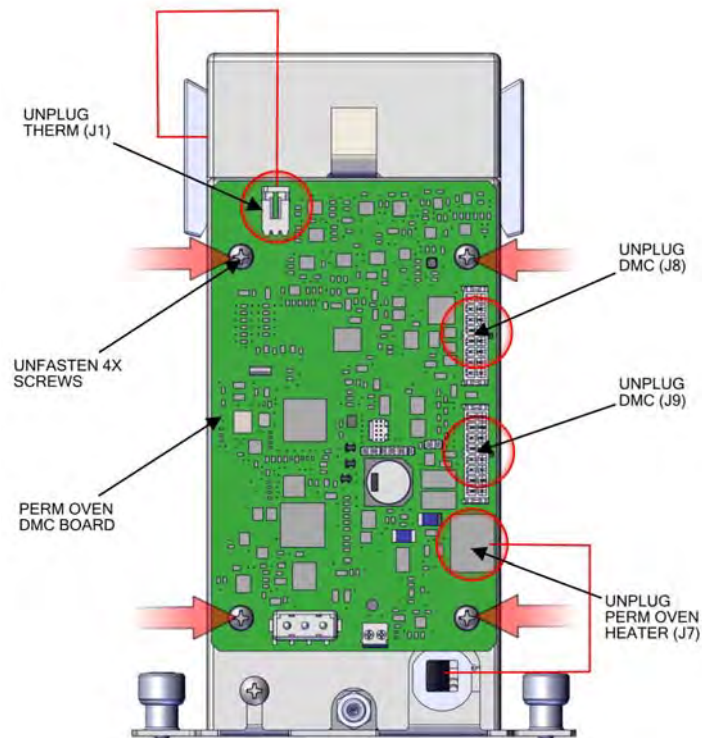
Equipment required:

Phillips drive, #2



**CAUTION** Allow oven to cool down prior to servicing. ▲

1. Turn instrument OFF, unplug power cord, and remove the cover (Figure 2-1).
2. Unplug all electrical J1, J7, J8, J9 as shown.
3. Using #2 Phillips drive, unfasten four 6-32 pan head screws.



**Figure 7-53.** Replacing the Permeation Oven Board

4. Replace permeation board and assemble in reverse order.



## Chapter 8

# System Description

The 43iQ deploys a set of modular subsystems that comprise the total instrument function. The core measurements for concentration are contained in Distributed Measurement and Control (DMC) modules. This chapter describes the function and location of the system components in the module framework, including firmware, electronics, and I/O function.

The 43iQ system components include:

- Optical Bench DMC
  - Heated hydrocarbon kicker
  - Optical Bench hardware with bandpass filters and mirrors
  - Flash lamp trigger assembly
  - Photomultiplier tube (PMT)
  - Photodetector
  - Optical bench DMC board
- Permeation Oven (optional)
- Common Electronics
  - Power Supply
  - System controller board
  - Backplane board
  - Front panel
  - I/O (optional)
- Peripherals Support System
  - Fan (on rear panel)
  - STEP POL board
  - Sample pump
  - Solenoid valve panel (optional)
- Flow Pressure DMC with flow restricting capillary

- Firmware

## **Optical Bench DMC**

The Optical Bench DMC contains the key components of the optical measurement that eventually results in SO<sub>2</sub> concentration. In the reaction chamber pulsating light from the flash lamp excites the SO<sub>2</sub> molecules. A condenser lens collects and focuses light from fluorescing SO<sub>2</sub> molecules onto the PMT assembly.

## **Heated Hydrocarbon Kicker**

The heated hydrocarbon kicker removes hydrocarbons from the gas stream while leaving the SO<sub>2</sub> concentration unaffected. It operates on a selective permeation principle using differential pressure to force hydrocarbon molecules to pass through the tube wall. The differential pressure is created across the tube wall as sample gas passes through a capillary tube which reduces its pressure. The sample gas is then fed to the shell side of the hydrocarbon kicker. The heated kicker operates at the same temperature as the optical bench and requires no additional power.

## **Optical Bench Hardware**

The optics section provides the light source for the fluorescence reaction and optimizes the reaction with a system of lenses and mirrors. It includes a flash lamp, condensing lens, bandpass mirror assembly and light baffle.

### **Condensing Lens**

The condensing lens focuses light from the flash lamp into the mirror assembly.

### **Mirror Assembly**

A set of four mirrors selectively reflects only those wavelengths used in exciting SO<sub>2</sub> molecules. This reflective filtering causes the radiation reaching the detection chamber to be more intense and more stable throughout the lifetime of the instrument.

### **Light Baffle**

The circular baffle helps keep stray light from entering the detection volume.

### **Bandpass Filter**

The bandpass filter restricts the light reaching the photomultiplier tube to the SO<sub>2</sub> fluorescence wavelengths.

## **Flash Lamp Trigger Assembly**

The flash lamp trigger assembly pulses the UV flash lamp at a rate of 10 times per second for improved signal-to-noise ratio and long term stability.

The lamp is operated in the pulsed mode for six major reasons:

- Long life
- High optical intensity – improved signal to noise ratio
- Small size
- Low power requirements – less than 1 watt
- Long-term stability
- Chopped signal processing – no dark current drift

## **Flash Lamp**

The flash lamp provides the ultraviolet light source that causes the fluorescence reaction in the SO<sub>2</sub> molecules.

## **Flash Trigger Board**

The flash trigger board is located in the base of the flash lamp assembly. It receives high voltage and the trigger signal from the measurement interface board and uses a small transformer to produce a short, high-voltage pulse to fire the flash lamp.

## **Flash Intensity Assembly**

The flash intensity assembly is located in the fluorescence chamber and continuously monitors the pulsating UV flash lamp. This photodetector is connected to a circuit that automatically compensates for fluctuations in flash lamp output.

## **Photomultiplier Tube**

The PMT power supply produces high voltage to operate the photomultiplier tube used in the measurement system. The output voltage is adjustable from approximately 600 to 1200 volts under software control. The PMT converts optical energy from the reaction to an electrical signal. This signal is sent to the input board which transmits it to the processor.

## **Optical Bench DMC Board**

The optical bench DMC board accepts the current signal from the PMT and converts it to a voltage, which is scaled by a factor of approximately 1, 10, or 100 depending on the full-scale range of the SO<sub>2</sub> channel.

## System Description

Permeation Oven (Optional)

### Bench Heater

The fluorescence chamber temperature is measured with a thermistor. The voltage across the thermistor is fed to the main processor for use in calculating and displaying the reaction chamber temperature. The voltage across the thermistor is also compared to a set-point voltage and used to control that the reaction chamber heaters to maintain a constant temperature.

### Permeation Oven (Optional)

The 43iQ can be configured with an optional permeation oven for generating SO<sub>2</sub> span gas. The permeation oven is configured as a DMC module with self-contained temperature measurements and heater controls. For more information, see “Internal Permeation Span Source” as described in Chapter 9, “Optional Equipment”.

### Common Electronics

The common electronics contain the core computational and power routing hardware for the 43iQ, and is replicated throughout other iQ series products (Figure 8–1). It also contains the front panel display, the USB ports, the Ethernet port, and the optional I/O interfaces (RS-485, analog, and digital).

Figure 8–2 shows the PCBA interconnect structure for the 43iQ, including options. The modular design of the instrument is conveyed in the architecture. Brief descriptions of the specific PCBAs follow.

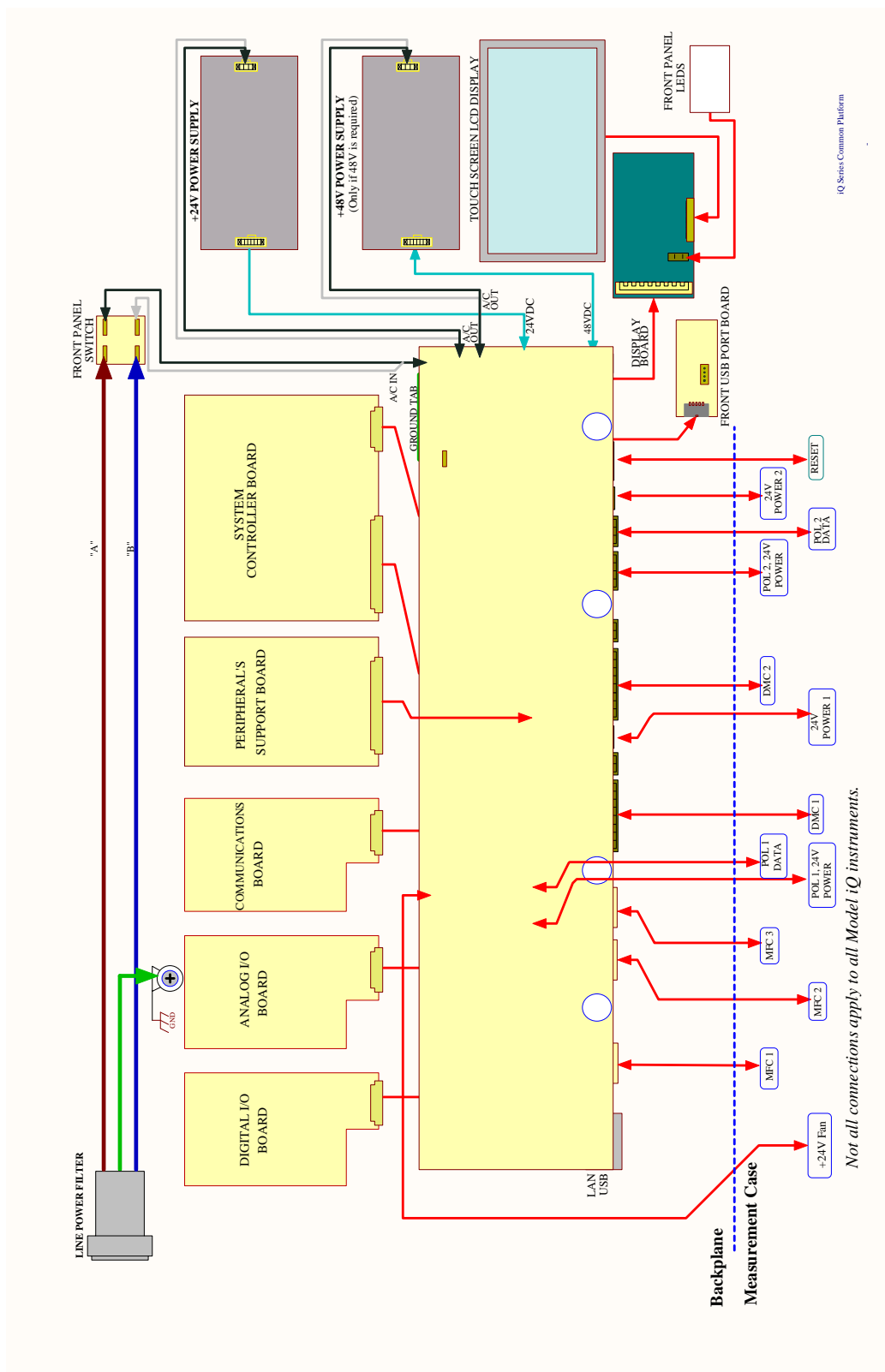
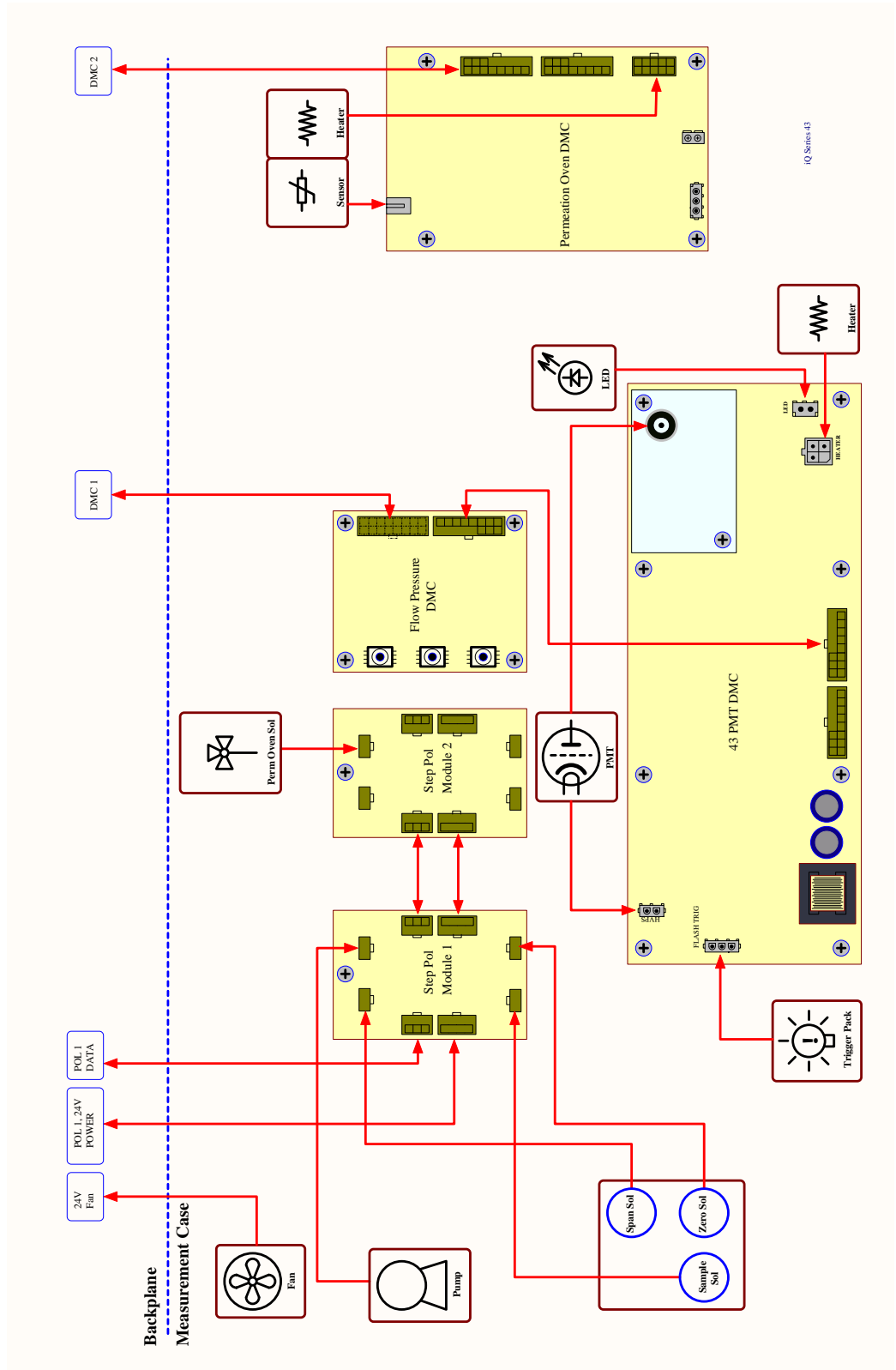


Figure 8–1. Common System Interconnect Diagram





**Figure 8-2.** 43iQ System Interconnect Diagram

## **Power Supply**

All electronics operate from a universal VDC supply, which is capable of auto-sensing the input voltage and working over all specified operating ranges. The 43iQ contains a 24 VDC channel for most electronics operation, including the pump and fan, and a 48 VDC channel dedicated specifically for optical bench heating.

## **Front Panel**

Front panel electronic components include the touch screen display, the on off switch, and two indicator LEDs for power and alarm status, as described in operational detail in Chapter 2, “[Installation and Setup](#)”.

## **I/O and Communication Components**

The iQ series instruments provide a number of methods for communicating the instrument results to the operator or external equipment. Every iQ series instrument includes a front panel display, 2 USB ports, and one Ethernet data port as standard equipment.

In addition, optional RS-232/485, analog I/O, and digital I/O ports are available to provide data to external systems as described in Chapter 9, “[Optional Equipment](#)”. The front panel GUI allows the operator to configure these output communication channels as described in Chapter 3, “[Operation](#)”.

## **System Controller Board**

The System Controller Board (SCB) contains the main processor, power supplies, and a sub-processor, and serves as the communication hub for the instrument. The SCB receives operator inputs from the front panel GUI and/or over optional I/O connections on the rear panel. The SCB sends commands to the other boards to control the functions of the instrument and to collect measurement and diagnostic information. The SCB outputs instrument status and measurement data to the GUI, Ethernet/USB, and to the optional rear-panel I/O. The SCB plugs into the backplane via a single connector and has physical retainers to secure placement.

## **Backplane Board**

The backplane board provides the routing and conditioning for +24 VDC (optional +48 VDC) and RS-485 communications within the instrument. It hosts the System Controller Board (SCB) and Peripherals Support Board (PSB) via direct plug ins, and similarly hosts optional I/O (communication, analog, and digital) with rear panel interfaces via direct plug in. It has connections for RS485 communication with and powering of DMCs and the STEP POL Module. It additionally routes the front panel display and driver, external USB and Ethernet.

## **Peripherals Support System**

The peripheral support system operates these additional devices that are needed, but do not require special feedback control or processing. These components are connected to a Peripherals Support Board (PSB).

**Fan** The chassis fan provides air cooling of the active electronic components.

**STEP POL Board** The STEP POL board provides high/low outputs for continuous operation or on/off states. The STEP POL board contains the basic circuitry to provide a programmable load to passive devices, either continuously, or on user or automated command. In the iQ Series instruments, the pump, solenoids, etc., are controlled off of the STEP POL board from commands generated via the PSB.

**Sample Pump** Internal vacuum pump for generating air/sample through the instrument

**Solenoid Valve Panel** Optional solenoid valves for switching between sample, zero, and span gases, and other optional components.

**Flow/Pressure DMC** The Flow/Pressure DMC is used measure instrument pressures that assure proper flow regulation and for sample pressure within the measurement bench for pressure corrections and compensation.

The DMC includes two pressure sensors that read 0-860 mmHg. These sensors are used with the coupled restricting capillary for flow control along with the downstream sample pump. The pressure differential determines the flow through the capillary. The upstream pressure is the measurement bench pressure, while the downstream pressure is at the pump inlet pressure.

**Firmware** Like the hardware, the firmware is modular and located within microprocessors distributed throughout the instrument. In the 43iQ, microprocessors containing firmware are located as follows:

- Optical Bench DMC
- Flow/Pressure DMC
- Peripherals Support Board
- Optional I/O (Communications, Digital, and Analog)

- Optional Permeation Oven

The firmware contains the active controls for their application, as well as self-identification and configuration for “plug and play” style operation. Each are associated with specific registers of two types:

- Modbus registers that are communicated from each microprocessor to the System Controller Board (SCB) via internal RS-485
- SNMP registers that are maintained in the software and SCB for health and data processing computation

The Modbus communication system operates on 1 second intervals. Within those intervals, data treatment like integration (whether analog or digital) and servo control, are embedded in the module firmware. The SCB receives the 1 second updates for higher level “software” processing and control via SNMP registers, some of which is interfaced with the front panel Graphical User Interface (GUI).

In addition to the operating registers, the 43iQ stores a historical data log in a MySQL database. The memory is provided on the same  $\mu$ SD card where the operating software resides, for which there is capability to store up to a year of data at 1 minute intervals. Chapter 3, “[Operation](#)” describes how this database is accessed and used including external memory downloads.



# Chapter 9

## Optional Equipment

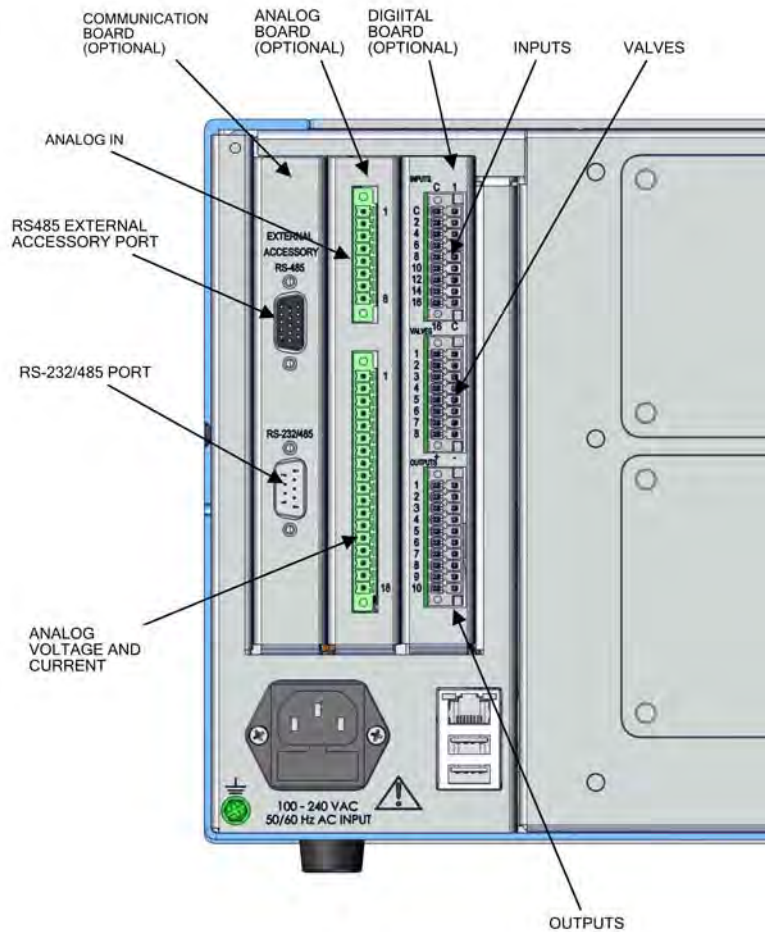
The 43iQ is available with the following options:

### Connecting External Devices

Several components are available for connecting external devices.

These connection options consist of three plug-in boards:

- Communication Board
- Analog I/O Board
- Digital I/O Board



**Figure 9-1.** I/O Expansion Replacement Boards

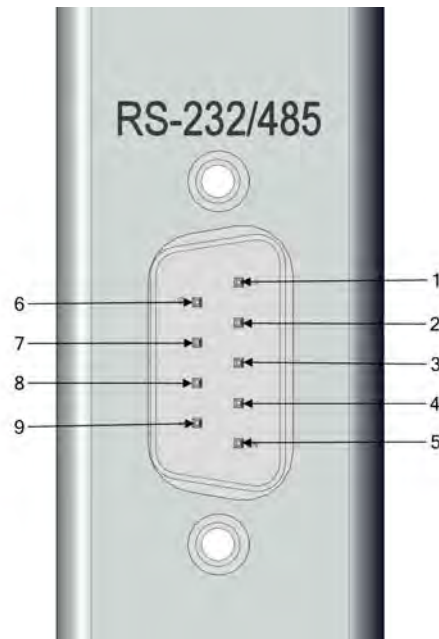
## Communication Board

The communication board consists of:

- RS-232/485 Port
- RS-485 External Accessory Port

### RS-232/RS-485 Port

The RS-232/RS-485 port uses a 9-pin serial connector with a bi-directional serial interface that can be configured for either RS-232 or RS-485 communication.



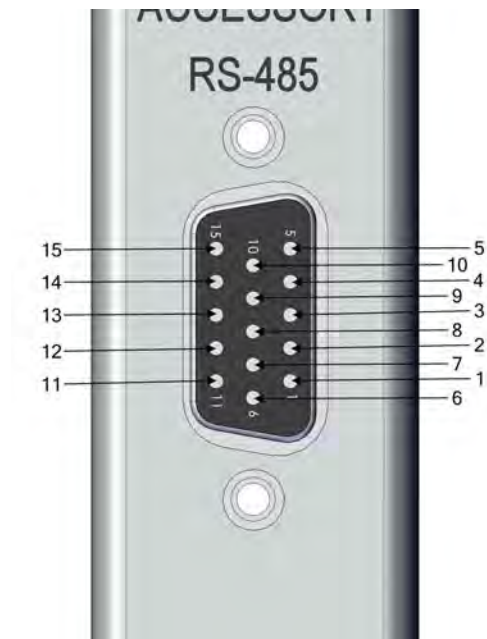
**Figure 9–2.** RS-232/RS-485 Port

**Table 9–1.** RS-232/RS-485 Port Terminal Assignment

Terminal Number	Signal Name
1	No Connect
2	RX/RS485_RX_P
3	TX/RS485_TX_N
4	No Connect
5	GND
6	No Connect
7	RTS/RS485_TX_P
8	CTS/RS485_RX_N
9	No Connect

**RS-485 External Accessory Port**

The RS-485 external accessory port uses a 15-pin serial connector for communication with external smart devices.



**Figure 9-3.** RS-485 External Accessory Port

**Table 9-2.** RS-485 External Accessory Port Terminal Assignment

Terminal Number	Signal Name
1	EXT_RS485_RX_N
2	EXT_RS485_RX_P
3	+5V (Fused @0.4A)
4	+5V (Fused @0.4A)
5	+5V (Fused @0.4A)
6	GND
7	GND
8	GND
9	EXT_RS485_TX_N
10	EXT_RS485_TX_P
11	+24V (Fused @0.4A)
12	+24V (Fused @0.4A)
13	+24V (Fused @0.4A)
14	+24V (Fused @0.4A)
15	+24V (Fused @0.4A)



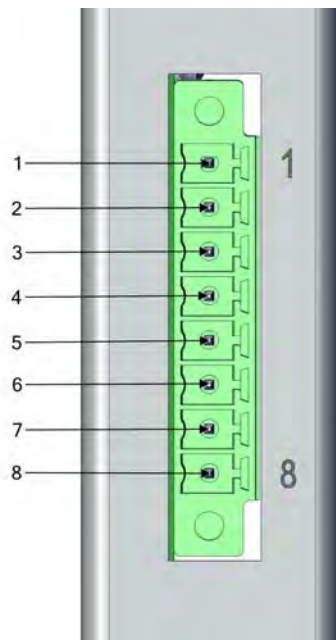
## Analog I/O Board

The Analog I/O Board consists of:

- 4 Isolated Analog Voltage Inputs, Input Voltage Range: 0–10 V
- 6 Isolated Analog Voltage Outputs, Three Ranges: 0–1.0 V, 0–5.0 V, 0–10 V
- 6 Isolated Analog Current Outputs, Two Ranges: 0mA–20mA, 4mA–20mA

## Analog Voltage Inputs

Table 9–3 lists the analog voltage inputs are used to monitor four external 0–10V signals.



**Figure 9–4.** Analog Voltage Inputs

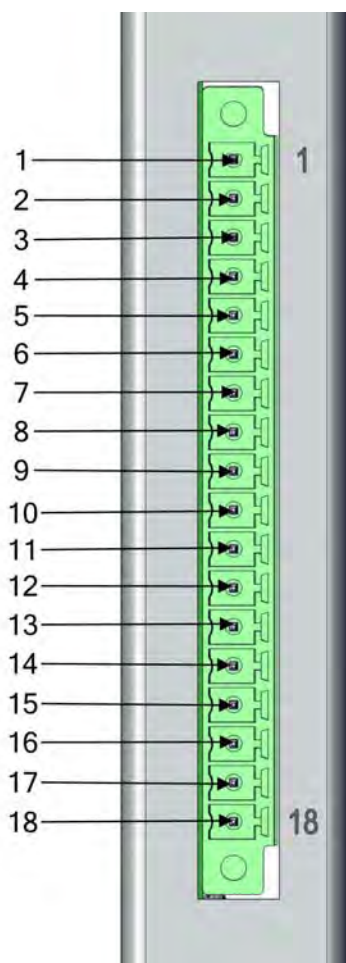
**Table 9–3.** Analog Voltage Inputs Assignment

Terminal Number	Signal Name
1	Analog In 1
2	Analog GND
3	Analog In 2
4	Analog GND
5	Analog In 3
6	Analog GND
7	Analog In 4
8	Analog GND

## Analog Voltage Outputs

There are six globally isolated, 16-bit, Analog Output channels, each with a Voltage Output, a Current Output and a common Return (isolated ground). The Analog Outputs are configured through the software control registers to select Voltage Output ranges 0–1 V, 0–5 V or 0–10 V, as well as Current Output ranges 0–20 mA or 4–20 mA. The maximum allowable load for each Current Output is 1000  $\Omega$ . All Voltage Outputs and Current Outputs are continuously monitored separately for accuracy.

The Analog Outputs may be used to control and report parameters pertinent to the analyzers' measured functions.



**Figure 9–5.** Analog Voltage and Current

**Table 9-4.** Analog Voltage and Current Assignment

Terminal Number	Signal Name
1	Current Out 1
2	Voltage Out 1
3	C/V Return 1
4	Current Out 2
5	Voltage Out 2
6	C/V Return 2
7	Current Out 3
8	Voltage Out 3
9	C/V Return 3
10	Current Out 4
11	Voltage Out 4
12	C/V Return 4
13	Current Out 5
14	Voltage Out 5
15	C/V Return 5
16	Current Out 6
17	Voltage Out 6
18	C/V Return 6

## Analog Output Calibration

The iQ series instruments provide for the ability to calibrate the analog outputs (both voltage and current) of the instruments. The basic procedure for both voltage and current are the same using the following procedure:

- Complete the connections of the recording device to the desired analog output channel. (See page 9-5 for the channel information).
- Calibrate the output channel low level.

**Note** When calibrating the current output when using the 0-20 mA scale, the low level will be set to 4 mA due to the inability to adjust the actual current output to below zero. ▲

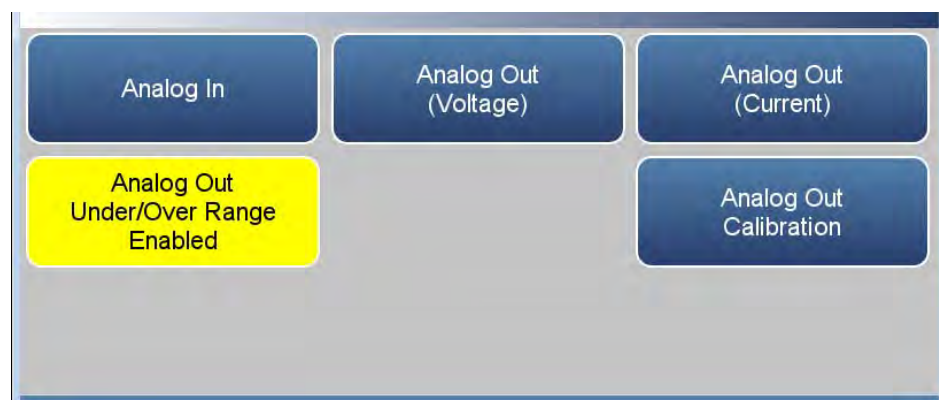
- Calibrate the output channel full scale.

## Analog Output Zero Calibration

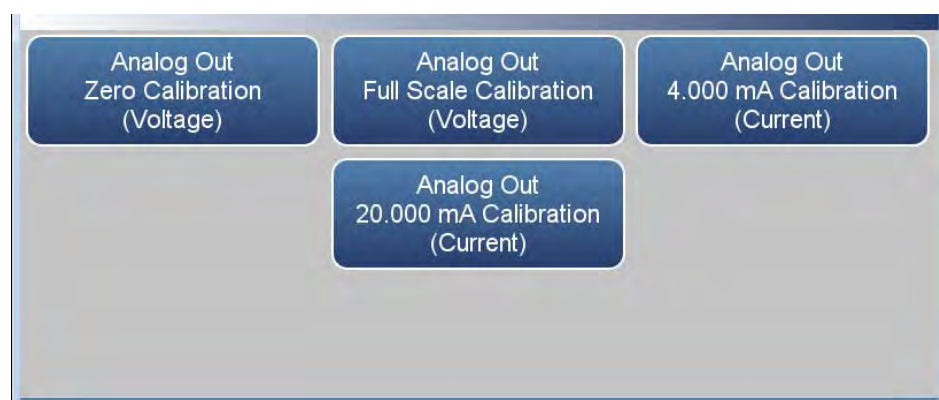
Use the following procedure to calibrate the output channel to low level. This analog output calibration procedure reflects the zero calibration for analog output voltage for demonstration purposes. To calibrate the 4 mA current calibration, follow the same procedure, by selecting the 4 mA current calibration option.

**Note** This adjustment should only be performed by an instrument service technician. ▲

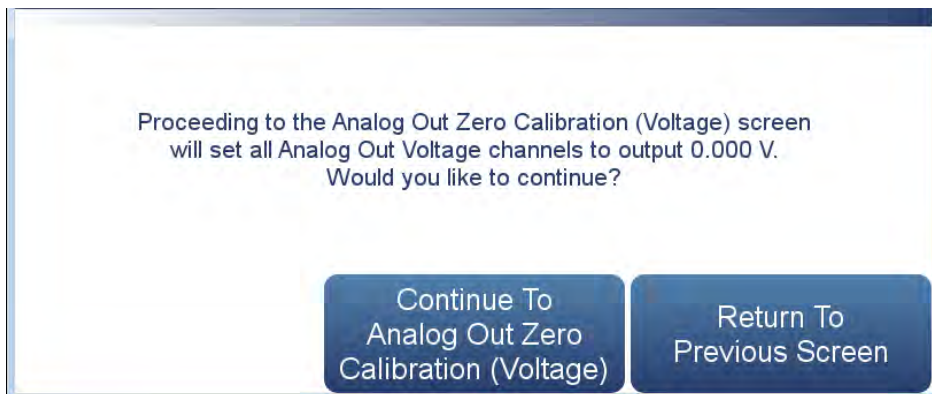
1. From the Home screen, choose **Settings>Communications>Analog I/O>Analog Out Calibration.**



2. Depending on the output type being used, select either Analog Out Zero Calibration (Voltage) or Analog Out 4.000 mA Calibration (Current).



3. A confirmation screen is presented. Select Continue to proceed with the calibration or Return to Previous Screen.



4. There are six columns for each of the six available output channels:

Channel	Output (V)	Decrease ↓↓	Decrease ↓	Increase ↑	Increase ↑↑	Commit
1	0.000	↓↓	↓	↑	↑↑	Commit
2	0.000	↓↓	↓	↑	↑↑	Commit
3	0.000	↓↓	↓	↑	↑↑	Commit
4	0.000	↓↓	↓	↑	↑↑	Commit
5	0.000	↓↓	↓	↑	↑↑	Commit
6	0.000	↓↓	↓	↑	↑↑	Commit

- *Output (V)*: Displays the actual output level at the terminal of the analog output board. For analog voltage, this value will default at zero. For analog current, this value will default at 4 mA.
- *Decrease ↓↓ and Decrease ↓*: Decreases the output by coarse or fine amounts
- *Increase ↑ and Increase ↑↑*: Increases the output by coarse and fine amounts.
- *Commit*: Accepts the changes to the analog output levels.

5. For the desired analog output channel, increase or decrease the output until the reading on the recording device indicates the proper value.

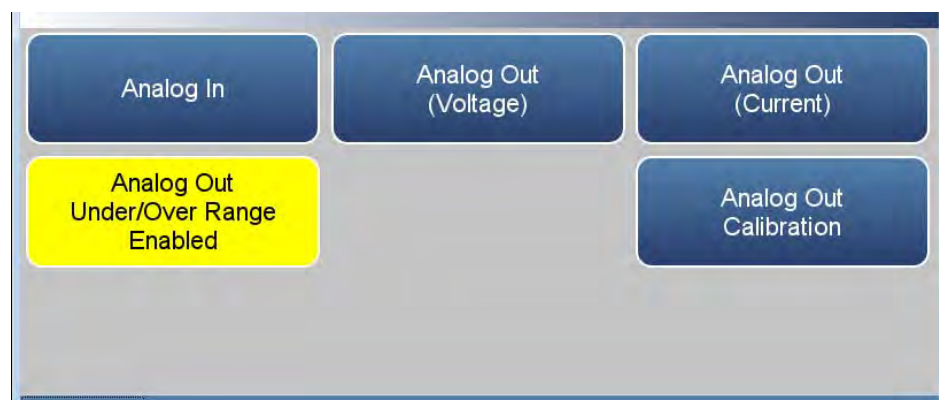
6. After making changes to the output levels, the commit button will turn green. To accept the changes, press the Commit button. To revert to the previous values, press the back button to return to the previous analog output calibration screen.

## Analog Output Full Scale Calibration

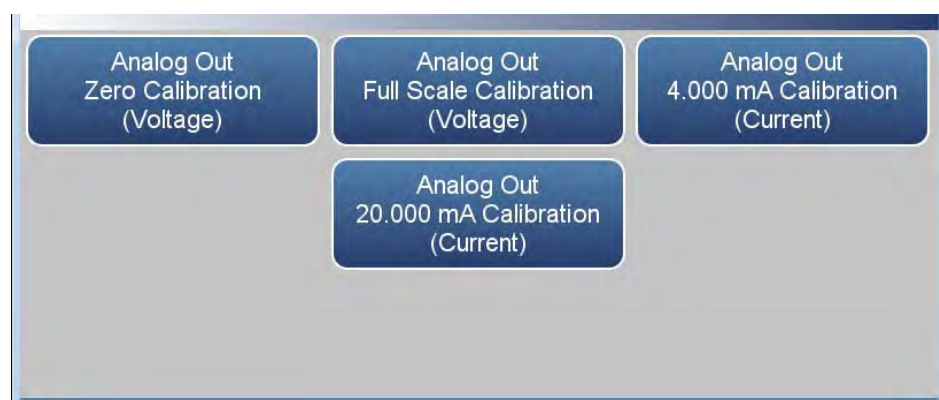
Use the following procedure to calibrate the output channel to full scale. This analog output calibration procedure reflects the full scale calibration for analog output voltage for demonstration purposes. To calibrate the 20 mA current calibration, follow the same procedure, by selecting the 20 mA current calibration option.

**Note** This adjustment should only be performed by an instrument service technician. ▲

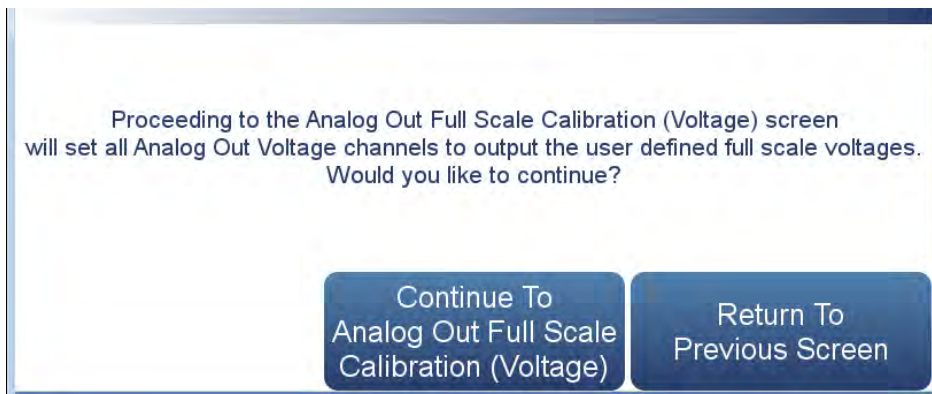
1. From the Home screen, choose **Settings>Communications>Analog I/O>Analog Output Calibration**.



2. Depending on the output type being used, select either Analog Out Full Scale Calibration (Voltage) or Analog Out 20.000 mA Calibration (Current).



3. A confirmation screen is presented. Select Continue to proceed with the calibration or Return to Previous Screen.



4. There are six columns for each of the six available output channels:

Channel	Output (V)	Decrease	Decrease	Increase	Increase	Commit
1	5.000	↓↓	↓	↑	↑↑	Commit
2	1.000	↓↓	↓	↑	↑↑	Commit
3	10.000	↓↓	↓	↑	↑↑	Commit
4	1.000	↓↓	↓	↑	↑↑	Commit
5	1.000	↓↓	↓	↑	↑↑	Commit
6	1.000	↓↓	↓	↑	↑↑	Commit

- *Output (V)*: Displays the actual output level at the terminal of the analog output board. For analog voltage, this value will default at the setting of the output channel, 1, 5, or 10 V. For analog current, this value will default at 20 mA.
  - *Decrease ↓↓ and Decrease ↓*: Decreases the output by coarse or fine amounts
  - *Increase ↑ and Increase ↑↑*: Increases the output by coarse and fine amounts.
  - *Commit*: Accepts the changes to the analog output levels.
5. For the desired analog output channel, increase or decrease the output until the reading on the recording device indicates the proper value.
  6. After making changes to the output levels, the commit button will turn green. To accept the changes, press the Commit button. To revert to the previous values, press the back button to return to the previous analog output calibration screen.

## Digital I/O Board

The digital I/O board consists of:

- 16 Digital Inputs (18 pin connector)
- 10 Digital Relay Switches (20 pin connector)
- 8 Valve Driver Outputs (16 pin connector)

### Digital Inputs

The digital inputs are TTL (3 V or 5 V) compatible and are pulled high within the instrument. The active state can be user defined in firmware.

- Logic Low Threshold: 0.8 V
- Logic High Threshold: 2.0 V
- Absolute allowable input voltages: -0.5 to 5.5 V

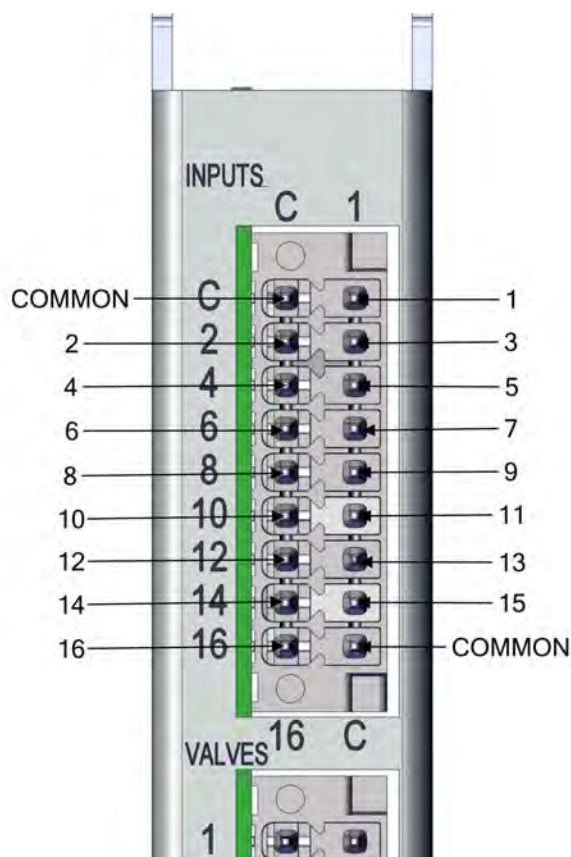


Figure 9–6. Digital Inputs

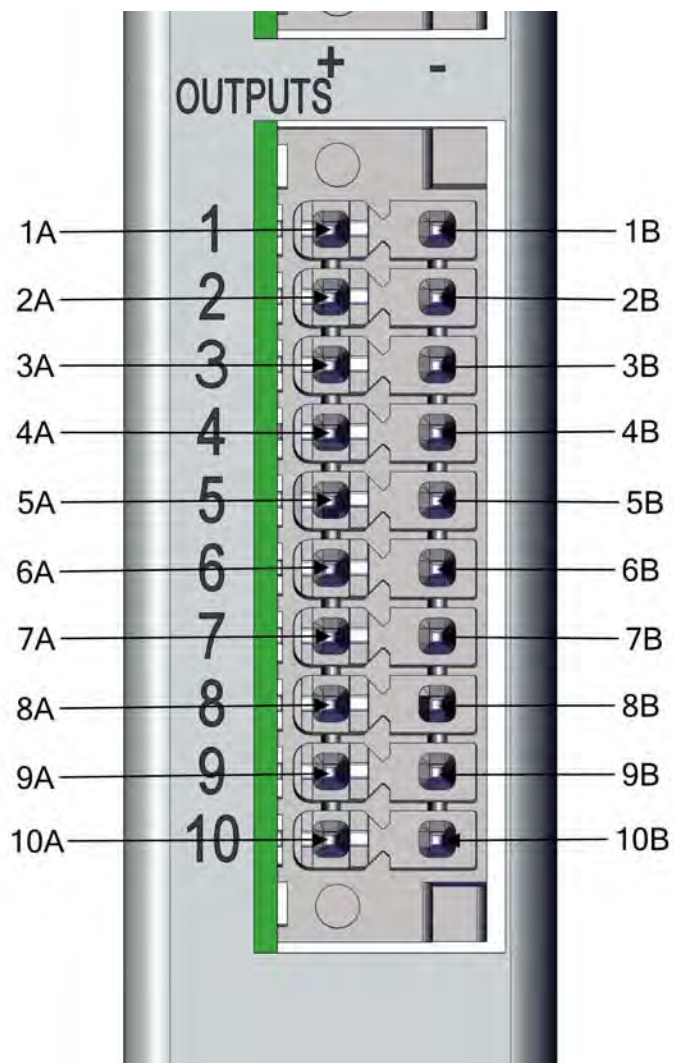


**Table 9–5.** Digital Inputs Terminal Assignment

<b>Terminal Number</b>	<b>Signal Name</b>
COMMON	
1	Digital In 1
2	Digital In 2
3	Digital In 3
4	Digital In 4
5	Digital In 5
6	Digital In 6
7	Digital In 7
8	Digital In 8
9	Digital In 9
10	Digital In 10
11	Digital In 11
12	Digital In 12
13	Digital In 13
14	Digital In 14
15	Digital In 15
16	Digital In 16
COMMON	

**Digital Relay Switches** Table 9–6 lists the digital relay switches.

- Maximum Voltage: 300 VDC
- Maximum Current: 500 mA
- Fuse: 800 mA



**Figure 9–7.** Digital Relay Switches

**Table 9–6.** Digital Relay Switch Assignment

<b>Terminal Number</b>	<b>Signal Name</b>
1A	Relay 1A
1B	Relay 1B
2A	Relay 2A
2B	Relay 2B
3A	Relay 3A
3B	Relay 3B
4A	Relay 4A
4B	Relay 4B
5A	Relay 5A
5B	Relay 5B
6A	Relay 6A
6B	Relay 6B
7A	Relay 7A
7B	Relay 7B
8A	Relay 8A
8B	Relay 8B
9A	Relay 9A
9B	Relay 9B
10A	Relay 10A
10B	Relay 10B

### Valve Driver Outputs

Table 9–7 lists the valve driver outputs.

- Actual Output Voltage: 22–24 VDC
- Maximum Current: 300 mA
- Both positive and negative outputs are protected from over voltage and over current by 500 mA fuses.

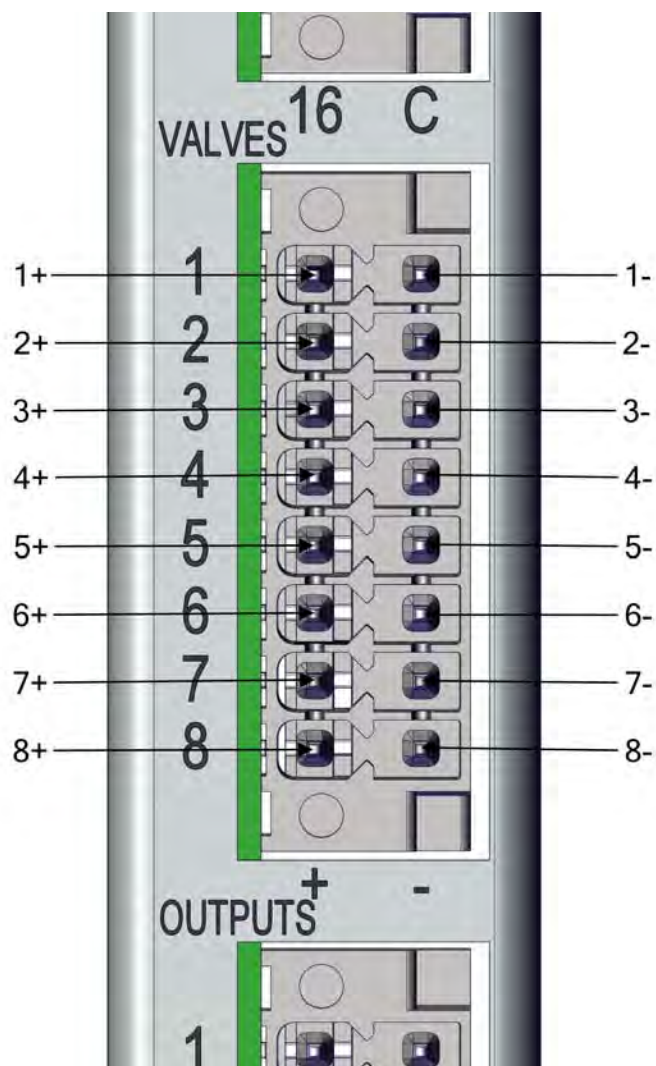


Figure 9–8. Valve Driver Outputs

**Table 9–7.** Valve Driver Outputs Assignment

<b>Terminal Number</b>	<b>Signal Name</b>
1+	Valve Drive 1+
1-	Valve Drive 1-
2+	Valve Drive 2+
2-	Valve Drive 2-
3+	Valve Drive 3+
3-	Valve Drive 3-
4+	Valve Drive 4+
4-	Valve Drive 4-
5+	Valve Drive 5+
5-	Valve Drive 5-
6+	Valve Drive 6+
6-	Valve Drive 6-
7+	Valve Drive 7+
7-	Valve Drive 7-
8+	Valve Drive 8+
8-	Valve Drive 8-

**Note** Intended for 24 V valves. These outputs will also drive any DC load of 22–24 VDC, up to 300 mA. ▲

## Internal Zero/Span and Sample Valves

With the zero/span assembly option, a source of span gas is connected to the SPAN port and a source of zero air is connected to the ZERO IN port. It may be necessary to use an atmospheric dump bypass plumbing arrangement to accomplish this.

For more information, refer to the “[Installation and Setup](#)” chapter and the “[Operation](#)” chapter.

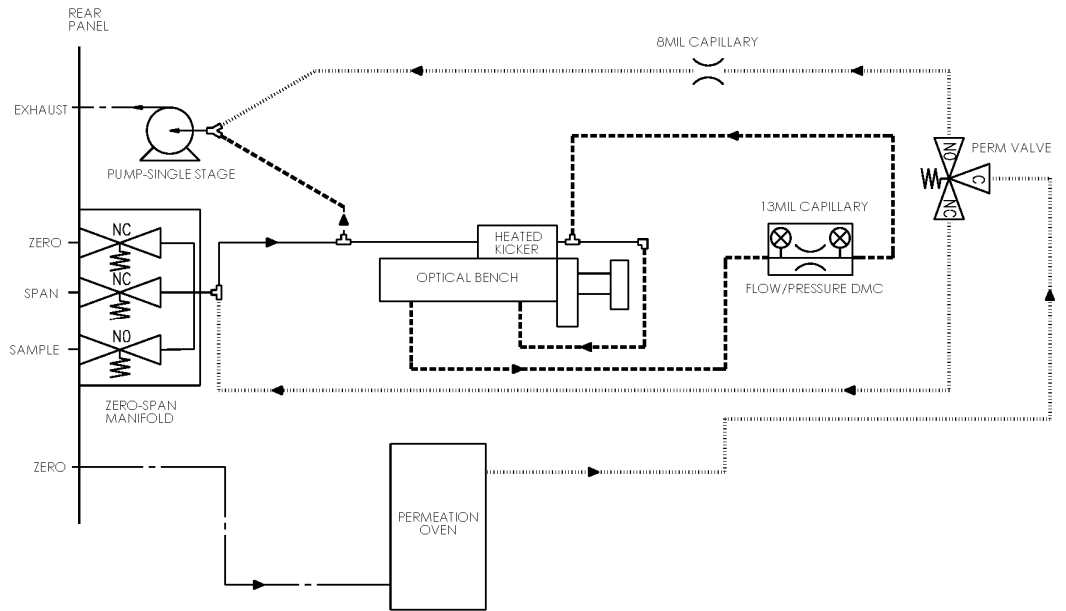
## Internal Permeation Span Source

The Internal Permeation Span Source option is designed to provide a simple span check. This option is intended as a quick, convenient check to be used between zero and span calibrations for determining instrument malfunction or drift. Because this option does not precisely control dilution gas flow, it should not be used as a basis for instrument zero and span adjustments, calibration updates or adjustment of ambient data.

Whenever there is an indication of possible instrument drift or malfunction, a full zero and calibration (Level 1) should be performed prior to corrective action. For further information on zero, span and calibration of air pollution monitors, refer to Section 2.0.9 of the US EPA's *Quality Assurance Handbook for Air Pollution Measurement Systems (Volume II)*.

[Figure 9–9](#) shows how this option is integrated with the 43iQ components. During normal operation, the pump draws zero air through the permeation oven and out the instrument exhaust. When performing a single point span check, the sample valve is energized, closing the sample valve, and the Perm valve is energized, opening the perm valve. This directs the zero air/SO<sub>2</sub> gas mixture from the permeation oven gas through the heated hydrocarbon kicker and into the optical bench.

**Optional Equipment**  
Internal Permeation Span Source



**Figure 9-9.** Internal Permeation Span Source Flow Diagram

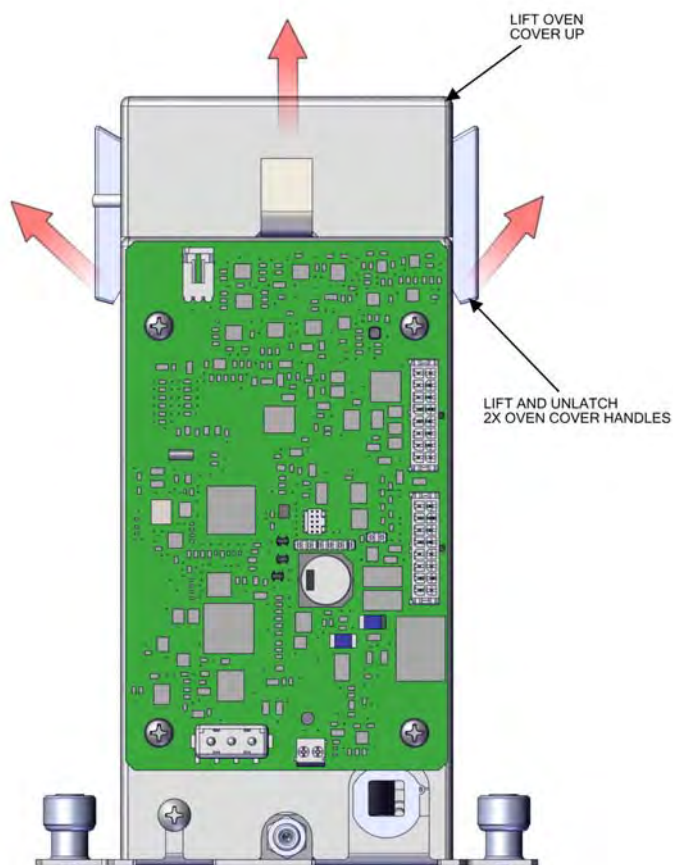
## Permeation Tube Installation



Use the following procedure to install the permeation tube.

**CAUTION** Allow oven to cool down prior to servicing. ▲

1. Lift oven cover up.
2. Lift and unlatch two oven cover handles.

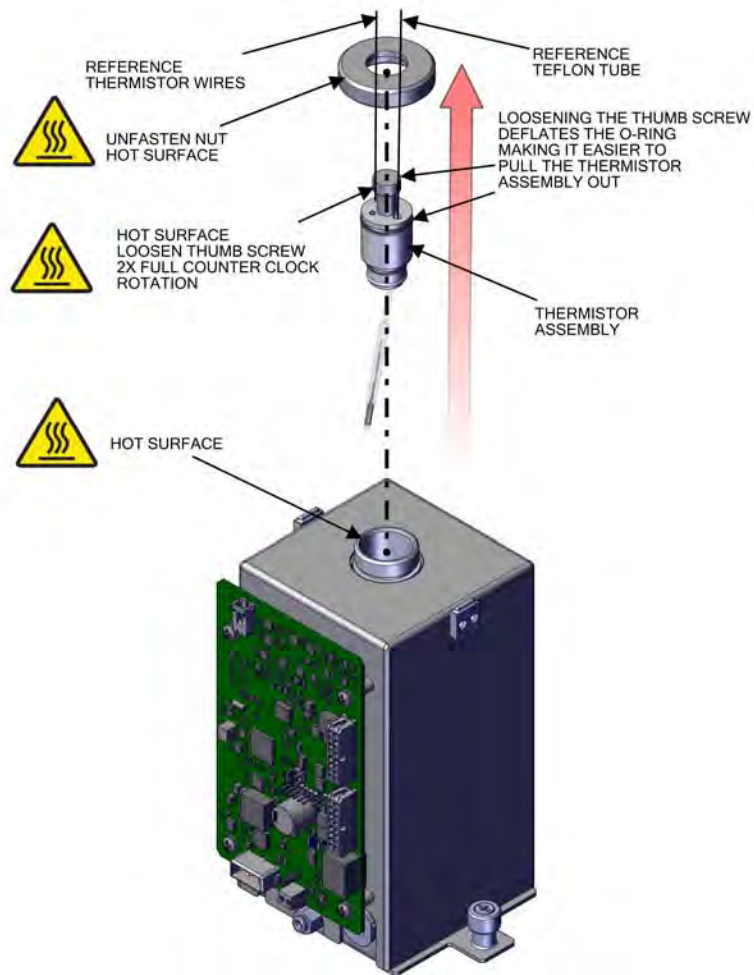


**Figure 9–10.** Installing Glass Tube pt 1

3. Unfasten nut. Loosen thumb screw 2X full counter clock rotation.
4. Loosening the thumb screw deflates the o-ring making it easier to pull the thermistor assembly out.



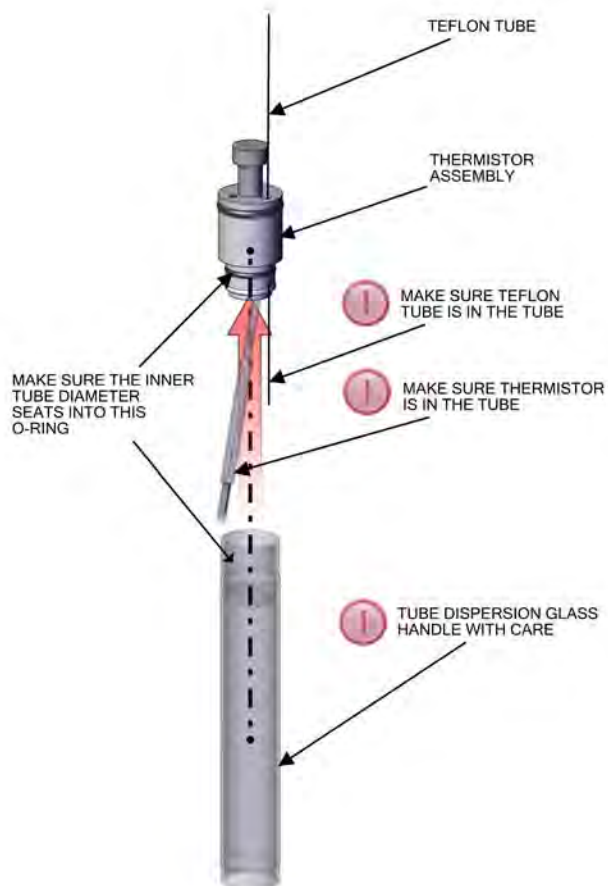
5. Pull thermistor assembly upwards.



**Figure 9–11.** Installing Glass Tube pt 2

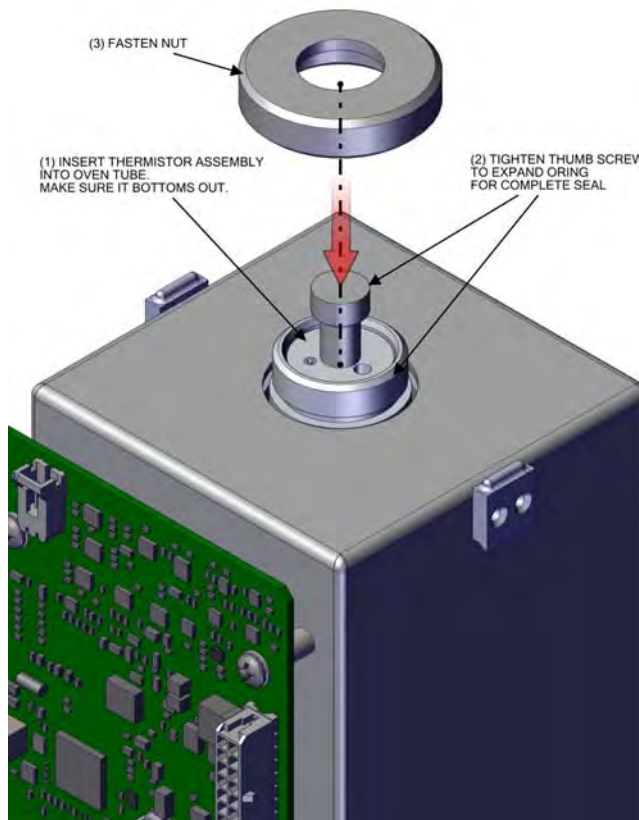
6. Push and gently twist tube dispersion glass upwards and seat into o-ring.

**Note** Make sure PTFE tube and thermistor is inside the dispersion glass. Keep glass clean by using kimwipes or similar material to handle glass. ▲



**Figure 9–12.** Installing Glass Tube pt 3

7. Insert thermistor assembly into oven tube. Make sure it bottoms out.
8. Tighten thumb screw to expand o-ring for complete seal.
9. Fasten nut.



**Figure 9–13.** Installing Glass Tube pt 4

10. Latch oven cover handles.

## Computation of Concentrations

The computation of SO<sub>2</sub> output level is shown in the following information. Note that it is assumed that all devices are properly calibrated and that all flows are corrected to 25 °C and 1 atm.

Permeation Tube:

$$Output (ppm) = \frac{(R)(K)}{Q_o}$$

Where:

R = permeation rate in ng/min

Q<sub>0</sub> = flow rate of gas (scc/min) into the charcoal scrubber during span mode

K = constant for the specific permeant = 24.45 / MW

MW = molecular weight

## **PTFE Particulate Filter**

A 5-10 micron pore size, two-inch diameter PTFE element is available for the 43iQ. This filter should be installed just prior to the SAMPLE bulkhead. When using a filter, all calibrations and span checks must be performed through the filter.



# Appendix A

## Safety, Warranty, and WEEE





### Safety

Review the following information carefully before using the instrument. This manual provides specific information on how to operate the instrument, however if the instrument is used in a manner not specified by the manufacturer, the protection provided by the equipment may be impaired.



### Safety and Equipment Damage Alerts

This manual contains important information to alert you to potential safety hazards and risks of equipment damage. Refer to the following types of alerts you may see in this manual.

#### Safety and Equipment Damage Alert Descriptions

Alert	Description
	<ul style="list-style-type: none"> <li>A hazard is present that will result in death or serious personal injury if the warning is ignored. ▲</li> </ul>
	<ul style="list-style-type: none"> <li>A hazard is present or an unsafe practice can result in serious personal injury if the warning is ignored. ▲</li> </ul>
	<ul style="list-style-type: none"> <li>The hazard or unsafe practice could result in minor to moderate personal injury if the warning is ignored. ▲</li> </ul>
 <b>Equipment Damage</b>	<ul style="list-style-type: none"> <li>The hazard or unsafe practice could result in property damage if the warning is ignored. ▲</li> </ul>

#### Safety and Equipment Damage Alerts in this Manual

Alert	Description
	<ul style="list-style-type: none"> <li>If the equipment is operated in a manner not specified by the manufacturer, the protection provided by the equipment may be impaired. ▲</li> <li>The service procedures in this manual are restricted to qualified service personnel only. ▲</li> </ul>
 <b>Equipment Damage</b>	<ul style="list-style-type: none"> <li>Do not attempt to lift the analyzer by the cover or other external fittings. ▲</li> <li>This adjustment should only be performed by an instrument service technician. ▲</li> </ul>

## **Warranty**

Seller warrants that the Products will operate or perform substantially in conformance with Seller's published specifications and be free from defects in material and workmanship, when subjected to normal, proper and intended usage by properly trained personnel, for the period of time set forth in the product documentation, published specifications or package inserts. If a period of time is not specified in Seller's product documentation, published specifications or package inserts, the warranty period shall be one (1) year from the date of shipment to Buyer for equipment and ninety (90) days for all other products (the "Warranty Period"). Seller agrees during the Warranty Period, to repair or replace, at Seller's option, defective Products so as to cause the same to operate in substantial conformance with said published specifications; provided that (a) Buyer shall promptly notify Seller in writing upon the discovery of any defect, which notice shall include the product model and serial number (if applicable) and details of the warranty claim; (b) after Seller's review, Seller will provide Buyer with service data and/or a Return Material Authorization ("RMA"), which may include biohazard decontamination procedures and other product-specific handling instructions; and (c) then, if applicable, Buyer may return the defective Products to Seller with all costs prepaid by Buyer. Replacement parts may be new or refurbished, at the election of Seller. All replaced parts shall become the property of Seller. Shipment to Buyer of repaired or replacement Products shall be made in accordance with the Delivery provisions of the Seller's Terms and Conditions of Sale. Consumables, including but not limited to lamps, fuses, batteries, bulbs and other such expendable items, are expressly excluded from the warranty under this warranty.

Notwithstanding the foregoing, Products supplied by Seller that are obtained by Seller from an original manufacturer or third party supplier are not warranted by Seller, but Seller agrees to assign to Buyer any warranty rights in such Product that Seller may have from the original manufacturer or third party supplier, to the extent such assignment is allowed by such original manufacturer or third party supplier.

In no event shall Seller have any obligation to make repairs, replacements or corrections required, in whole or in part, as the result of (i) normal wear and tear, (ii) accident, disaster or event of force majeure, (iii) misuse, fault or negligence of or by Buyer, (iv) use of the Products in a manner for which they were not designed, (v) causes external to the Products such as, but not limited to, power failure or electrical power surges, (vi) improper storage and handling of the Products or (vii) use of the Products in combination with equipment or software not supplied by Seller. If Seller determines that Products for which Buyer has requested warranty services are not covered by the warranty hereunder, Buyer shall pay or reimburse Seller for all costs of investigating and responding to such request at Seller's then

prevailing time and materials rates. If Seller provides repair services or replacement parts that are not covered by the warranty provided in this warranty, Buyer shall pay Seller therefor at Seller's then prevailing time and materials rates. ANY INSTALLATION, MAINTENANCE, REPAIR, SERVICE, RELOCATION OR ALTERATION TO OR OF, OR OTHER TAMPERING WITH, THE PRODUCTS PERFORMED BY ANY PERSON OR ENTITY OTHER THAN SELLER WITHOUT SELLER'S PRIOR WRITTEN APPROVAL, OR ANY USE OF REPLACEMENT PARTS NOT SUPPLIED BY SELLER, SHALL IMMEDIATELY VOID AND CANCEL ALL WARRANTIES WITH RESPECT TO THE AFFECTED PRODUCTS.

THE OBLIGATIONS CREATED BY THIS WARRANTY STATEMENT TO REPAIR OR REPLACE A DEFECTIVE PRODUCT SHALL BE THE SOLE REMEDY OF BUYER IN THE EVENT OF A DEFECTIVE PRODUCT. EXCEPT AS EXPRESSLY PROVIDED IN THIS WARRANTY STATEMENT, SELLER DISCLAIMS ALL OTHER WARRANTIES, WHETHER EXPRESS OR IMPLIED, ORAL OR WRITTEN, WITH RESPECT TO THE PRODUCTS, INCLUDING WITHOUT LIMITATION ALL IMPLIED WARRANTIES OF MERCHANTABILITY OR FITNESS FOR ANY PARTICULAR PURPOSE. SELLER DOES NOT WARRANT THAT THE PRODUCTS ARE ERROR-FREE OR WILL ACCOMPLISH ANY PARTICULAR RESULT.



## WEEE Compliance


This product is required to comply with the European Union's Waste Electrical & Electronic Equipment (WEEE) Directive 2002/96/EC. It is marked with the following symbol:



Thermo Fisher Scientific has contracted with one or more recycling/disposal companies in each EU Member State, and this product should be disposed of or recycled through them. Further information on Thermo Fisher Scientific's compliance with these Directives, the recyclers in your country, and information on Thermo Fisher Scientific products which may assist the detection of substances subject to the RoHS Directive are available at: [www.thermoscientific.com/WEEERoHS](http://www.thermoscientific.com/WEEERoHS).

## WEEE Symbol

The following symbol and description identify the WEEE marking used on the instrument and in the associated documentation.

Symbol	Description
	Marking of electrical and electronic equipment which applies to electrical and electronic equipment falling under the Directive 2002/96/EC (WEEE) and the equipment that has been put on the market after 13 August 2005. ▲

# Appendix B

## Quick Reference

### List of Figures

<b>Figure 1–1.</b> 43iQ Front .....	1-2
<b>Figure 1–2.</b> 43iQ Flow Schematic.....	1-4
<b>Figure 1–3.</b> 43iQ Flow Schematic with Zero Span.....	1-4
<b>Figure 1–4.</b> Bench Mount Assembly (dimensions in inches [mm]) .....	1-7
<b>Figure 1–5.</b> Rack Mount Assembly (dimensions in inches [mm]) .....	1-8
<b>Figure 1–6.</b> Rack Mount Requirements.....	1-9
<b>Figure 1–7.</b> Rack Requirements Part 2 .....	1-9
<b>Figure 2–1.</b> Removing the Cover.....	2-2
<b>Figure 2–2.</b> Installing Feet .....	2-3
<b>Figure 2–3.</b> Removing the Front Panel .....	2-4
<b>Figure 2–4.</b> Installing Ears and Handles.....	2-5
<b>Figure 2–5.</b> 43iQ Rear Panel .....	2-7
<b>Figure 2–6.</b> Atmospheric Dump Bypass Plumbing .....	2-7
<b>Figure 2–7.</b> Front Panel and Touchscreen Display .....	2-8
<b>Figure 4–1.</b> Cylinder Gas Dilution System.....	4-3
<b>Figure 4–2.</b> Permeation Tube System .....	4-5
<b>Figure 5–1.</b> Single Stage Pump .....	5-2
<b>Figure 5–2.</b> Pump Rebuilding.....	5-4
<b>Figure 7–1.</b> Properly Grounded Antistatic Wrist Strap .....	7-2
<b>Figure 7–2.</b> 43iQ Component Layout Top View .....	7-4
<b>Figure 7–3.</b> 43iQ Component Layout Side View.....	7-4
<b>Figure 7–4.</b> Replacing the Fuses.....	7-5
<b>Figure 7–5.</b> Start with Top Right Corner of Fan Cover.....	7-6
<b>Figure 7–6.</b> Removing the Fan Cover.....	7-6
<b>Figure 7–7.</b> Unplugging the Fan Cable .....	7-7
<b>Figure 7–8.</b> Replacing the Fan .....	7-8
<b>Figure 7–9.</b> Unplugging the Fan Cable .....	7-9
<b>Figure 7–10.</b> Unplugging the DMC Cable.....	7-10
<b>Figure 7–11.</b> Unfasten Hardware Front for Measurement Side Removal .....	7-10
<b>Figure 7–12.</b> Unfasten Hardware Rear for Measurement Side Removal.....	7-11
<b>Figure 7–13.</b> Replacing the LCD Module.....	7-12
<b>Figure 7–14.</b> Remove Electrical Cables from LCD.....	7-13

<b>Figure 7–15.</b> I/O Replacement, Arm .....	7-14
<b>Figure 7–16.</b> I/O Replacement, Remove Board .....	7-14
<b>Figure 7–17.</b> I/O Replacement, Install .....	7-15
<b>Figure 7–18.</b> I/O Replacement, Close Arm Alignment .....	7-15
<b>Figure 7–19.</b> Replacing the Peripherals Support Board .....	7-16
<b>Figure 7–20.</b> Flow Pressure Board, Disconnect DMC Cable .....	7-17
<b>Figure 7–21.</b> Flow Pressure Board, Screws .....	7-18
<b>Figure 7–22.</b> Remove Pump, Disconnect and Unfasten .....	7-20
<b>Figure 7–23.</b> Pump Removal, Keyway.....	7-21
<b>Figure 7–24.</b> Pump replacing, Unfasten Screws .....	7-21
<b>Figure 7–25.</b> Remove Capillary, Disconnect and Unfasten .....	7-22
<b>Figure 7–26.</b> Capillary Plate, Keyway .....	7-23
<b>Figure 7–27.</b> Capillary and O-Ring Replace .....	7-23
<b>Figure 7–28.</b> Removing Power Supply .....	7-25
<b>Figure 7–29.</b> Replacing Power Supply .....	7-25
<b>Figure 7–30.</b> Unplug and Unfasten Step POL Board.....	7-26
<b>Figure 7–31.</b> Clear Partition Keyway Step POL Board.....	7-27
<b>Figure 7–32.</b> Step POL Board 1 Switch Settings .....	7-28
<b>Figure 7–33.</b> Optional Step POL Board 2 Switch Settings .....	7-28
<b>Figure 7–34.</b> Removing the DMC Optical Bench Removal from Instrument....	7-30
<b>Figure 7–35.</b> Removing the Optical Bench Assembly.....	7-31
<b>Figure 7–36.</b> Removing the Optical Bench Assembly pt 2 .....	7-32
<b>Figure 7–37.</b> Removing the PMT Assembly.....	7-33
<b>Figure 7–38.</b> Removing the PMT Cover .....	7-34
<b>Figure 7–39.</b> Replacing the PMT.....	7-34
<b>Figure 7–40.</b> Removing and Replacing the Flasher Pack.....	7-35
<b>Figure 7–41.</b> Replacing the Flasher Pack Lamp.....	7-36
<b>Figure 7–42.</b> Replacing the Photo Lamp Detector Board pt 1 .....	7-37
<b>Figure 7–43.</b> Replacing the Photo Lamp Detector board pt 2 .....	7-38
<b>Figure 7–44.</b> Removing and Replacing the Kicker Assembly .....	7-39
<b>Figure 7–45.</b> Replacing the Manifold pt 1 .....	7-40
<b>Figure 7–46.</b> Replacing the Manifold pt 2 .....	7-41
<b>Figure 7–47.</b> Replacing the Manifold pt 3 .....	7-41
<b>Figure 7–48.</b> Removing and Replacing the Solenoid Valve pt 1 .....	7-42
<b>Figure 7–49.</b> Removing and Replacing the Solenoid Valve pt 2 .....	7-43
<b>Figure 7–50.</b> Perm Oven pt 1.....	7-44
<b>Figure 7–51.</b> Finger Push and Release Tubing .....	7-45
<b>Figure 7–52.</b> Perm Oven Replacement pt 2 .....	7-46
<b>Figure 7–53.</b> Replacing the Permeation Oven Board.....	7-47
<b>Figure 8–1.</b> Common System Interconnect Diagram.....	8-5

<b>Figure 8–2.</b> 43iQ System Interconnect Diagram .....	8-6
<b>Figure 9–1.</b> I/O Expansion Replacement Boards .....	9-1
<b>Figure 9–2.</b> RS-232/RS-485 Port .....	9-2
<b>Figure 9–3.</b> RS-485 External Accessory Port .....	9-3
<b>Figure 9–4.</b> Analog Voltage Inputs .....	9-4
<b>Figure 9–5.</b> Analog Voltage and Current .....	9-5
<b>Figure 9–6.</b> Digital Inputs .....	9-11
<b>Figure 9–7.</b> Digital Relay Switches .....	9-13
<b>Figure 9–8.</b> Valve Driver Outputs .....	9-15
<b>Figure 9–9.</b> Internal Permeation Span Source Flow Diagram .....	9-18
<b>Figure 9–10.</b> Installing Glass Tube pt 1 .....	9-19
<b>Figure 9–11.</b> Installing Glass Tube pt 2 .....	9-20
<b>Figure 9–12.</b> Installing Glass Tube pt 3 .....	9-21
<b>Figure 9–13.</b> Installing Glass Tube pt 4 .....	9-22

## List of Tables

<b>Table 1–1.</b> 43iQ Specifications .....	1-5
<b>Table 1–2.</b> 43iQ Optional Permeation Oven Specifications .....	1-6
<b>Table 3–1.</b> Data Logging Variables .....	3-30
<b>Table 3–2.</b> Streaming Data Variables .....	3-33
<b>Table 6–1.</b> 43iQ Troubleshooting Guide .....	6-1
<b>Table 9–1.</b> RS-232/RS-485 Port Terminal Assignment .....	9-2
<b>Table 9–2.</b> RS-485 External Accessory Port Terminal Assignment .....	9-3
<b>Table 9–3.</b> Analog Voltage Inputs Assignment .....	9-4
<b>Table 9–4.</b> Analog Voltage and Current Assignment .....	9-6
<b>Table 9–5.</b> Digital Inputs Terminal Assignment .....	9-12
<b>Table 9–6.</b> Digital Relay Switch Assignment .....	9-14
<b>Table 9–7.</b> Valve Driver Outputs Assignment .....	9-16



# Appendix C

## GNU Lesser General Public License

Version 2.1, February 1999

Copyright (C) 1991, 1999 Free Software Foundation, Inc.

51 Franklin Street, Fifth Floor, Boston, MA 02110-1301 USA

Everyone is permitted to copy and distribute verbatim copies of this license document, but changing it is not allowed.

BECAUSE THE LIBRARY IS LICENSED FREE OF CHARGE,  
THERE IS NO WARRANTY FOR THE LIBRARY, TO THE EXTENT  
PERMITTED BY APPLICABLE LAW.

The Open Source code used in the development of this product will be provided for a period of 3-years from date of purchase to the original purchaser provided they supply Thermo Fisher Scientific with the applicable serial number for the product the Open Source code is being requested for.

[This is the first released version of the Lesser GPL. It also counts as the successor of the GNU Library Public License, version 2, hence the version number 2.1.]

### Preamble

The licenses for most software are designed to take away your freedom to share and change it. By contrast, the GNU General Public Licenses are intended to guarantee your freedom to share and change free software--to make sure the software is free for all its users.

This license, the Lesser General Public License, applies to some specially designated software packages--typically libraries--of the Free Software Foundation and other authors who decide to use it. You can use it too, but we suggest you first think carefully about whether this license or the ordinary General Public License is the better strategy to use in any particular case, based on the explanations below.

When we speak of free software, we are referring to freedom of use, not price. Our General Public Licenses are designed to make sure that you have the freedom to distribute copies of free software (and charge for this service if you wish); that you receive source code or can get it if you want it;

that you can change the software and use pieces of it in new free programs; and that you are informed that you can do these things.

To protect your rights, we need to make restrictions that forbid distributors to deny you these rights or to ask you to surrender these rights. These restrictions translate to certain responsibilities for you if you distribute copies of the library or if you modify it.

For example, if you distribute copies of the library, whether gratis or for a fee, you must give the recipients all the rights that we gave you. You must make sure that they, too, receive or can get the source code. If you link other code with the library, you must provide complete object files to the recipients, so that they can relink them with the library after making changes to the library and recompiling it. And you must show them these terms so they know their rights.

We protect your rights with a two-step method: (1) we copyright the library, and (2) we offer you this license, which gives you legal permission to copy, distribute and/or modify the library.

To protect each distributor, we want to make it very clear that there is no warranty for the free library. Also, if the library is modified by someone else and passed on, the recipients should know that what they have is not the original version, so that the original author's reputation will not be affected by problems that might be introduced by others.

Finally, software patents pose a constant threat to the existence of any free program. We wish to make sure that a company cannot effectively restrict the users of a free program by obtaining a restrictive license from a patent holder. Therefore, we insist that any patent license obtained for a version of the library must be consistent with the full freedom of use specified in this license.

Most GNU software, including some libraries, is covered by the ordinary GNU General Public License. This license, the GNU Lesser General Public License, applies to certain designated libraries, and is quite different from the ordinary General Public License. We use this license for certain libraries in order to permit linking those libraries into non-free programs.

When a program is linked with a library, whether statically or using a shared library, the combination of the two is legally speaking a combined work, a derivative of the original library. The ordinary General Public License therefore permits such linking only if the entire combination fits its criteria of freedom. The Lesser General Public License permits more lax criteria for linking other code with the library.

We call this license the "Lesser" General Public License because it does Less to protect the user's freedom than the ordinary General Public License. It also provides other free software developers Less of an advantage over competing non-free programs. These disadvantages are the reason we use

the ordinary General Public License for many libraries. However, the Lesser license provides advantages in certain special circumstances.

For example, on rare occasions, there may be a special need to encourage the widest possible use of a certain library, so that it becomes a de-facto standard. To achieve this, non-free programs must be allowed to use the library. A more frequent case is that a free library does the same job as widely used non-free libraries. In this case, there is little to gain by limiting the free library to free software only, so we use the Lesser General Public License.

In other cases, permission to use a particular library in non-free programs enables a greater number of people to use a large body of free software. For example, permission to use the GNU C Library in non-free programs enables many more people to use the whole GNU operating system, as well as its variant, the GNU/Linux operating system.

Although the Lesser General Public License is Less protective of the users' freedom, it does ensure that the user of a program that is linked with the Library has the freedom and the wherewithal to run that program using a modified version of the Library.

The precise terms and conditions for copying, distribution and modification follow. Pay close attention to the difference between a "work based on the library" and a "work that uses the library". The former contains code derived from the library, whereas the latter must be combined with the library in order to run.

#### GNU LESSER GENERAL PUBLIC LICENSE TERMS AND CONDITIONS FOR COPYING, DISTRIBUTION AND MODIFICATION

0. This License Agreement applies to any software library or other program which contains a notice placed by the copyright holder or other authorized party saying it may be distributed under the terms of this Lesser General Public License (also called "this License"). Each licensee is addressed as "you".

A "library" means a collection of software functions and/or data prepared so as to be conveniently linked with application programs (which use some of those functions and data) to form executables.

The "Library", below, refers to any such software library or work which has been distributed under these terms. A "work based on the Library" means either the Library or any derivative work under copyright law: that is to say, a work containing the Library or a portion of it, either verbatim or with modifications and/or translated straightforwardly into another language. (Hereinafter, translation is included without limitation in the term "modification".)



"Source code" for a work means the preferred form of the work for making modifications to it. For a library, complete source code means all the source code for all modules it contains, plus any associated interface definition files, plus the scripts used to control compilation and installation of the library.

Activities other than copying, distribution and modification are not covered by this License; they are outside its scope. The act of running a program using the Library is not restricted, and output from such a program is covered only if its contents constitute a work based on the Library (independent of the use of the Library in a tool for writing it). Whether that is true depends on what the Library does and what the program that uses the Library does.

1. You may copy and distribute verbatim copies of the Library's complete source code as you receive it, in any medium, provided that you conspicuously and appropriately publish on each copy an appropriate copyright notice and disclaimer of warranty; keep intact all the notices that refer to this License and to the absence of any warranty; and distribute a copy of this License along with the Library.

You may charge a fee for the physical act of transferring a copy, and you may at your option offer warranty protection in exchange for a fee.

2. You may modify your copy or copies of the Library or any portion of it, thus forming a work based on the Library, and copy and distribute such modifications or work under the terms of Section 1 above, provided that you also meet all of these conditions:

- a) The modified work must itself be a software library.
- b) You must cause the files modified to carry prominent notices stating that you changed the files and the date of any change.
- c) You must cause the whole of the work to be licensed at no charge to all third parties under the terms of this License.
- d) If a facility in the modified Library refers to a function or a table of data to be supplied by an application program that uses the facility, other than as an argument passed when the facility is invoked, then you must make a good faith effort to ensure that, in the event an application does not supply such function or table, the facility still operates, and performs whatever part of its purpose remains meaningful.

(For example, a function in a library to compute square roots has a purpose that is entirely well-defined independent of the application. Therefore, Subsection 2d requires that any application-supplied function or table used by this function must be optional: if the application does not supply it, the square root function must still compute square roots.)

These requirements apply to the modified work as a whole. If identifiable sections of that work are not derived from the Library, and can be reasonably considered independent and separate works in themselves, then this License, and its terms, do not apply to those sections when you distribute them as separate works. But when you distribute the same sections as part of a whole which is a work based on the Library, the distribution of the whole must be on the terms of this License, whose permissions for other licensees extend to the entire whole, and thus to each and every part regardless of who wrote it.

Thus, it is not the intent of this section to claim rights or contest your rights to work written entirely by you; rather, the intent is to exercise the right to control the distribution of derivative or collective works based on the Library.

In addition, mere aggregation of another work not based on the Library with the Library (or with a work based on the Library) on a volume of a storage or distribution medium does not bring the other work under the scope of this License.

3. You may opt to apply the terms of the ordinary GNU General Public License instead of this License to a given copy of the Library. To do this, you must alter all the notices that refer to this License, so that they refer to the ordinary GNU General Public License, version 2, instead of to this License. (If a newer version than version 2 of the ordinary GNU General Public License has appeared, then you can specify that version instead if you wish.) Do not make any other change in these notices.

Once this change is made in a given copy, it is irreversible for that copy, so the ordinary GNU General Public License applies to all subsequent copies and derivative works made from that copy. This option is useful when you wish to copy part of the code of the Library into a program that is not a library.

4. You may copy and distribute the Library (or a portion or derivative of it, under Section 2) in object code or executable form under the terms of Sections 1 and 2 above provided that you accompany it with the complete corresponding machine-readable source code, which must be distributed under the terms of Sections 1 and 2 above on a medium customarily used for software interchange.

If distribution of object code is made by offering access to copy from a designated place, then offering equivalent access to copy the source code from the same place satisfies the requirement to distribute the source code, even though third parties are not compelled to copy the source along with the object code.

5. A program that contains no derivative of any portion of the Library, but is designed to work with the Library by being compiled or linked with it, is

called a "work that uses the Library". Such a work, in isolation, is not a derivative work of the Library, and therefore falls outside the scope of this License.

However, linking a "work that uses the Library" with the Library creates an executable that is a derivative of the Library (because it contains portions of the Library), rather than a "work that uses the library". The executable is therefore covered by this License. Section 6 states terms for distribution of such executables.

When a "work that uses the Library" uses material from a header file that is part of the Library, the object code for the work may be a derivative work of the Library even though the source code is not. Whether this is true is especially significant if the work can be linked without the Library, or if the work is itself a library. The threshold for this to be true is not precisely defined by law.

If such an object file uses only numerical parameters, data structure layouts and accessors, and small macros and small inline functions (ten lines or less in length), then the use of the object file is unrestricted, regardless of whether it is legally a derivative work. (Executables containing this object code plus portions of the Library will still fall under Section 6.)

Otherwise, if the work is a derivative of the Library, you may distribute the object code for the work under the terms of Section 6. Any executables containing that work also fall under Section 6, whether or not they are linked directly with the Library itself.

6. As an exception to the Sections above, you may also combine or link a "work that uses the Library" with the Library to produce a work containing portions of the Library, and distribute that work under terms of your choice, provided that the terms permit modification of the work for the customer's own use and reverse engineering for debugging such modifications.

You must give prominent notice with each copy of the work that the Library is used in it and that the Library and its use are covered by this License. You must supply a copy of this License. If the work during execution displays copyright notices, you must include the copyright notice for the Library among them, as well as a reference directing the user to the copy of this License. Also, you must do one of these things:

a) Accompany the work with the complete corresponding machine-readable source code for the Library including whatever changes were used in the work (which must be distributed under Sections 1 and 2 above); and, if the work is an executable linked with the Library, with the complete machine-readable "work that uses the Library", as object code and/or source code, so that the user can modify the Library and then relink to produce a modified executable containing the modified Library. (It is

understood that the user who changes the contents of definitions files in the Library will not necessarily be able to recompile the application to use the modified definitions.)

- b) Use a suitable shared library mechanism for linking with the Library. A suitable mechanism is one that (1) uses at run time a copy of the library already present on the user's computer system, rather than copying library functions into the executable, and (2) will operate properly with a modified version of the library, if the user installs one, as long as the modified version is interface-compatible with the version that the work was made with.
- c) Accompany the work with a written offer, valid for at least three years, to give the same user the materials specified in Subsection 6a, above, for a charge no more than the cost of performing this distribution.
- d) If distribution of the work is made by offering access to copy from a designated place, offer equivalent access to copy the above specified materials from the same place.
- e) Verify that the user has already received a copy of these materials or that you have already sent this user a copy.

For an executable, the required form of the "work that uses the Library" must include any data and utility programs needed for reproducing the executable from it. However, as a special exception, the materials to be distributed need not include anything that is normally distributed (in either source or binary form) with the major components (compiler, kernel, and so on) of the operating system on which the executable runs, unless that component itself accompanies the executable.

It may happen that this requirement contradicts the license restrictions of other proprietary libraries that do not normally accompany the operating system. Such a contradiction means you cannot use both them and the Library together in an executable that you distribute.

7. You may place library facilities that are a work based on the Library side-by-side in a single library together with other library facilities not covered by this License, and distribute such a combined library, provided that the separate distribution of the work based on the Library and of the other library facilities is otherwise permitted, and provided that you do these two things:

- a) Accompany the combined library with a copy of the same work based on the Library, uncombined with any other library facilities. This must be distributed under the terms of the Sections above.
- b) Give prominent notice with the combined library of the fact that part of it is a work based on the Library, and explaining where to find the accompanying uncombined form of the same work.

8. You may not copy, modify, sublicense, link with, or distribute the Library except as expressly provided under this License. Any attempt otherwise to copy, modify, sublicense, link with, or distribute the Library is void, and will automatically terminate your rights under this License. However, parties who have received copies, or rights, from you under this License will not have their licenses terminated so long as such parties remain in full compliance.

9. You are not required to accept this License, since you have not signed it. However, nothing else grants you permission to modify or distribute the Library or its derivative works. These actions are prohibited by law if you do not accept this License. Therefore, by modifying or distributing the Library (or any work based on the Library), you indicate your acceptance of this License to do so, and all its terms and conditions for copying, distributing or modifying the Library or works based on it.

10. Each time you redistribute the Library (or any work based on the Library), the recipient automatically receives a license from the original licensor to copy, distribute, link with or modify the Library subject to these terms and conditions. You may not impose any further restrictions on the recipients' exercise of the rights granted herein. You are not responsible for enforcing compliance by third parties with this License.

11. If, as a consequence of a court judgment or allegation of patent infringement or for any other reason (not limited to patent issues), conditions are imposed on you (whether by court order, agreement or otherwise) that contradict the conditions of this License, they do not excuse you from the conditions of this License. If you cannot distribute so as to satisfy simultaneously your obligations under this License and any other pertinent obligations, then as a consequence you may not distribute the Library at all. For example, if a patent license would not permit royalty-free redistribution of the Library by all those who receive copies directly or indirectly through you, then the only way you could satisfy both it and this License would be to refrain entirely from distribution of the Library.

If any portion of this section is held invalid or unenforceable under any particular circumstance, the balance of the section is intended to apply, and the section as a whole is intended to apply in other circumstances.

It is not the purpose of this section to induce you to infringe any patents or other property right claims or to contest validity of any such claims; this section has the sole purpose of protecting the integrity of the free software distribution system which is implemented by public license practices. Many people have made generous contributions to the wide range of software distributed through that system in reliance on consistent application of that system; it is up to the author/donor to decide if he or she is willing to distribute software through any other system and a licensee cannot impose that choice.

This section is intended to make thoroughly clear what is believed to be a consequence of the rest of this License.

12. If the distribution and/or use of the Library is restricted in certain countries either by patents or by copyrighted interfaces, the original copyright holder who places the Library under this License may add an explicit geographical distribution limitation excluding those countries, so that distribution is permitted only in or among countries not thus excluded. In such case, this License incorporates the limitation as if written in the body of this License.

13. The Free Software Foundation may publish revised and/or new versions of the Lesser General Public License from time to time. Such new versions will be similar in spirit to the present version, but may differ in detail to address new problems or concerns.

Each version is given a distinguishing version number. If the Library specifies a version number of this License which applies to it and "any later version", you have the option of following the terms and conditions either of that version or of any later version published by the Free Software Foundation. If the Library does not specify a license version number, you may choose any version ever published by the Free Software Foundation.

14. If you wish to incorporate parts of the Library into other free programs whose distribution conditions are incompatible with these, write to the author to ask for permission. For software which is copyrighted by the Free Software Foundation, write to the Free Software Foundation; we sometimes make exceptions for this. Our decision will be guided by the two goals of preserving the free status of all derivatives of our free software and of promoting the sharing and reuse of software generally.

#### NO WARRANTY

15. BECAUSE THE LIBRARY IS LICENSED FREE OF CHARGE, THERE IS NO WARRANTY FOR THE LIBRARY, TO THE EXTENT PERMITTED BY APPLICABLE LAW. EXCEPT WHEN OTHERWISE STATED IN WRITING THE COPYRIGHT HOLDERS AND/OR OTHER PARTIES PROVIDE THE LIBRARY "AS IS" WITHOUT WARRANTY OF ANY KIND, EITHER EXPRESSED OR IMPLIED, INCLUDING, BUT NOT LIMITED TO, THE IMPLIED WARRANTIES OF MERCHANTABILITY AND FITNESS FOR A PARTICULAR PURPOSE. THE ENTIRE RISK AS TO THE QUALITY AND PERFORMANCE OF THE LIBRARY IS WITH YOU. SHOULD THE LIBRARY PROVE DEFECTIVE, YOU ASSUME THE COST OF ALL NECESSARY SERVICING, REPAIR OR CORRECTION.

16. IN NO EVENT UNLESS REQUIRED BY APPLICABLE LAW OR AGREED TO IN WRITING WILL ANY COPYRIGHT HOLDER, OR

ANY OTHER PARTY WHO MAY MODIFY AND/OR REDISTRIBUTE THE LIBRARY AS PERMITTED ABOVE, BE LIABLE TO YOU FOR DAMAGES, INCLUDING ANY GENERAL, SPECIAL, INCIDENTAL OR CONSEQUENTIAL DAMAGES ARISING OUT OF THE USE OR INABILITY TO USE THE LIBRARY (INCLUDING BUT NOT LIMITED TO LOSS OF DATA OR DATA BEING RENDERED INACCURATE OR LOSSES SUSTAINED BY YOU OR THIRD PARTIES OR A FAILURE OF THE LIBRARY TO OPERATE WITH ANY OTHER SOFTWARE), EVEN IF SUCH HOLDER OR OTHER PARTY HAS BEEN ADVISED OF THE POSSIBILITY OF SUCH DAMAGES.

## END OF TERMS AND CONDITIONS

### How to Apply These Terms to Your New Libraries

If you develop a new library, and you want it to be of the greatest possible use to the public, we recommend making it free software that everyone can redistribute and change. You can do so by permitting redistribution under these terms (or, alternatively, under the terms of the ordinary General Public License).

To apply these terms, attach the following notices to the library. It is safest to attach them to the start of each source file to most effectively convey the exclusion of warranty; and each file should have at least the "copyright" line and a pointer to where the full notice is found.

<one line to give the library's name and a brief idea of what it does.>  
Copyright (C) <year> <name of author>

This library is free software; you can redistribute it and/or modify it under the terms of the GNU Lesser General Public License as published by the Free Software Foundation; either version 2.1 of the License, or (at your option) any later version.

This library is distributed in the hope that it will be useful, but WITHOUT ANY WARRANTY; without even the implied warranty of MERCHANTABILITY or FITNESS FOR A PARTICULAR PURPOSE. See the GNU Lesser General Public License for more details.

You should have received a copy of the GNU Lesser General Public License along with this library; if not, write to the Free Software Foundation, Inc., 51 Franklin Street, Fifth Floor, Boston, MA 02110-1301 USA

Also add information on how to contact you by electronic and paper mail.

You should also get your employer (if you work as a programmer) or your school, if any, to sign a "copyright disclaimer" for the library, if necessary. Here is a sample; alter the names:

Yoyodyne, Inc., hereby disclaims all copyright interest in the library `Frob' (a library for tweaking knobs) written by James Random Hacker.

<signature of Ty Coon>, 1 April 1990

Ty Coon, President of Vice

That's all there is to it!

Nokia Qt LGPL Exception version 1.1

As an additional permission to the GNU Lesser General Public License version 2.1, the object code form of a "work that uses the Library" may incorporate material from a header file that is part of the Library. You may distribute such object code under terms of your choice, provided that:

- (i) the header files of the Library have not been modified; and
- (ii) the incorporated material is limited to numerical parameters, data structure layouts, accessors, macros, inline functions and templates; and
- (iii) you comply with the terms of Section 6 of the GNU Lesser General Public License version 2.1.

Moreover, you may apply this exception to a modified version of the Library, provided that such modification does not involve copying material from the Library into the modified Library's header files unless such material is limited to (i) numerical parameters; (ii) data structure layouts; (iii) accessors; and (iv) small macros, templates and inline functions of five lines or less in length.

Furthermore, you are not required to apply this additional permission to a modified version of the Library.







**thermo**scientific



**USA**

27 Forge Parkway  
Franklin, MA 02038  
Ph: (508) 520-0430  
Fax: (508) 520-2800  
orders.aqi@thermofisher.com

**India**

C/327, TTC Industrial Area  
MIDC Pawane  
New Mumbai 400 705, India  
Ph: +91 22 4157 8800  
india@thermofisher.com

**China**

+Units 702-715, 7th Floor  
Tower West, Yonghe  
Beijing, China 100007  
Ph: +86 10 84193588  
info.eid.china@thermofisher.com

**Europe**

Ion Path, Road Three,  
Winsford, Cheshire CW73GA UK  
Ph: +44 1606 548700  
Fax: +44 1606 548711  
sales.epm.uk@thermofisher.com

Find out more at [thermofisher.com/43iQ](http://thermofisher.com/43iQ)

**ThermoFisher**  
SCIENTIFIC